

SYSTEM DESCRIPTION

System description:

Thermal break aluminium profiles system, hardware and gaskets for the fabrication of Sliding windows and doors.

System features and characteristics:

Profile system equipped with sealing gaskets and brushes. The system it is created to obtain all type of windows and doors as well composite models for terrance doors, shop front door and ground floor treatment frames.

System relevant information:

- Sliding Aluminium System for Windows and Doors with concealed frames
- Sash width: 55mm
- Sash height: 76.5mm
- Fixed frame width: 110mm-222mm
- Fixed frame height: 49mm-17.5mm
- Glazing depth: 24mm and 40 mm
- Profiles overlap: 8 mm
- Profiles design: To be cut at 45° and 90°
- Sealing : By gaskets and brushes mounted on the frames.
- Latching : Simple and multipoints (optional).
- Rollers: Double wheel rollers
- Models: All type of sliding windows and doors including fixed frames and insect screen.

System dimensions:

This system it is composed of fix frames profiles of various depths for specifics architectural applications and building solutions, the sashes of 55 mm of depth are built in order to obtain windows and doors .The standard fix frame depth it is of 110 mm and it is completed by specific profiles for water evacuation and mosquitos screen application. The profiles are based on 8 mm of overlap between sash and fix frame. For all detail and specific application please consult the field 'Sections' of this catalogue about the various windows and doors model sections.

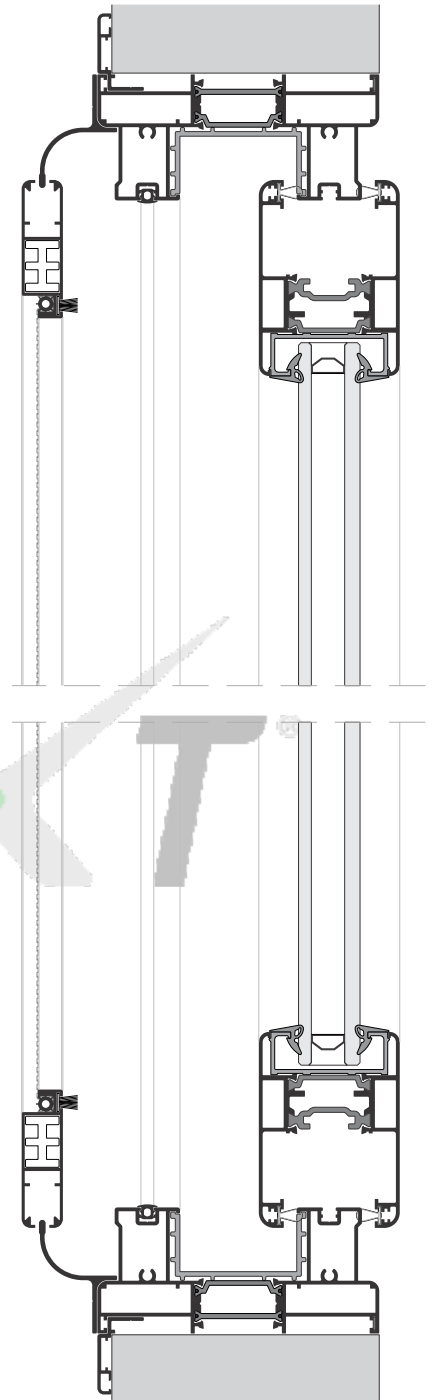

Field of application:

The system have been created and studied to be apply on private buildings as well on public buildings for casement windows and doors, terrance doors, ground floor treatments ans shop front frames.

Design features:

The system is composed of various design solutions. The external lines are lightly rounded conferring to the profiles a good design and equilibrate sections. The system is designed in order to ensure good performance and have at the same time a modern style.

Materials:

Extruded aluminium collection for Sliding windows and doors.

The profiles extruded against our exclusive aluminium design conception, in alluminium alloy EN AW - 6063 (EN 573-3 & E755-2), phisical state and treatment according to EN 515. The alloys conform to the ASTM and BS norms

The Phisical state and the owen treatments of the profles correspond to the class TA - T5. The profiles are conform to the dimensional tolerances according to the norm EN 12020-2.

Surface Treatment:

All the surface treatment are conform to the quality lables QUALICOAT for Podwer Coating and QUALANOD for anodization.

Anodizing we guarantee the minimum thickness of 15 micron up to 25 microns according to international norms.

The powder coating is done with thermosetting and Polyesters Polymeric powders, the profiles are finished into special coating owens, where the powders reach the righth hardness trought a heat treatment.

Surface treatment resistance:

The surface treatment done according to QUALANOAD and QUALICOAT Quality labels shall be guarantee against corrosion and surface aging degradacion for a period of 5-10 years. The surface treatments shall resist to normal and marine exposition without been effected by corrosion or loss of shiness. The most relevant factors influencing the surface treatment life lasting are the direct exposure to chemicals. The direct exposure in the front of the sea and/or salty water it may reduce the life lasting of the components. The exposure to heavy polluted environment may cause also problems. A regular cleaning with Ph neutral water and soaps increase the components life.

Safety:

In order to prevent injuries or/an accidents the windows and doors are to be installed as displayed into this catalogue, anchoring the components to the building and using original only accessories. The fixing should be made according to the National norms for security and safety use.

Glazing and panels specifications:

Glazing should be mounted according to the catalogue drawings and selectd in accordance to the performances required in consideration of energy saving, safety, acustic and solar radiation factors. These performances are depending on the type of glass installed. The glass mounted shall be conform to the national norms for glazing.

Gaskets:

The gaskets used during assembling and installing the components should be only the ones created for this system and displayed in this product catalogue. The use of other gaskets or/and brushes it may cause functional and design problems. The gaskets used should conform to the national norms for windows and doors safety applications, do not release toxic smokes in case of fire and insure the performances during all the component life lasting.

Sealing products:

All the sealing products employed during the fabrication of the components and installing the components on the building are to conform to the specific uses for aluminium profiles and surface treatments. Sealing products should be PH neutral and specifically studied do not start any chemical or/and corrosive reaction with the windows and doors components, accessories, gaskets and surface treatments.

Accessories:

All the accessories used for the manufacturing, mounting, functioning and installation of this system are specifically studied for this system in order to insure performances and a correct functioning of the models. The use of other accessories different from the ones displayed in this catalogue it may effect or/and make dangerous the functioning of the component. Only the accessories studied for this sliding are the ones to be used.

Acoustic performances:

The Acoustical performances of the Windows and doors are depending on the correct mounting of all accessories and gaskets according to the catalogue specifications. The performances that you will obtain depend on various factors.

The nature of the sound, the distance of the component from the noise origin and the orientation of diffusion of the noise. The factor influencing the final performances of the window are the sound performances of the glass and the air permeability window's classification. In general to have an approximate idea of the final performances of the components from the Certified Insulating Power expressed in dB (decibel) of the glass, you should subtract from 8 to 2 decibels (8-5-2) 8 db for the lowest classification, 5 db for a medium performance to the air and only 2 db in case the window is classified to the top performances for air permeability. Only Laboratory tests will provide you in all the case a scientific and trustable classification.

Thermal performances:

The Thermal performances of the window are determined by the U_f (Profile Thermal value), the U_g (glass thermal value) and by the surfaces of the frames (A_f) and glass surface (A_g). The choice of the windows thermal performances are depending on the building code requirements and on the results on terms of energy saving that you need to obtain. The Thermal performances of all the windows (U_w) are to be calculated using the following approximated formula:

$$U_w = (A_g U_g + A_f U_f + L_g Y_l) / (A_g + A_f).$$

Mechanical strength:

The Aluminium System and all accessories should resist to the standard loading methods of testing for windows and doors according to the national norms and codes. The method of testing is described into the norms.

PROFILE

Frame Profile

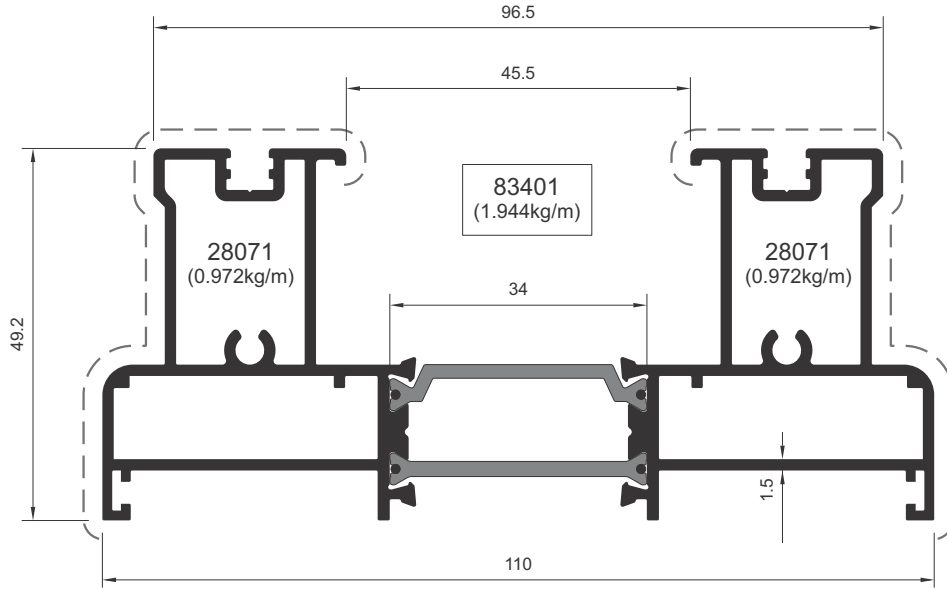

Scale 1:1

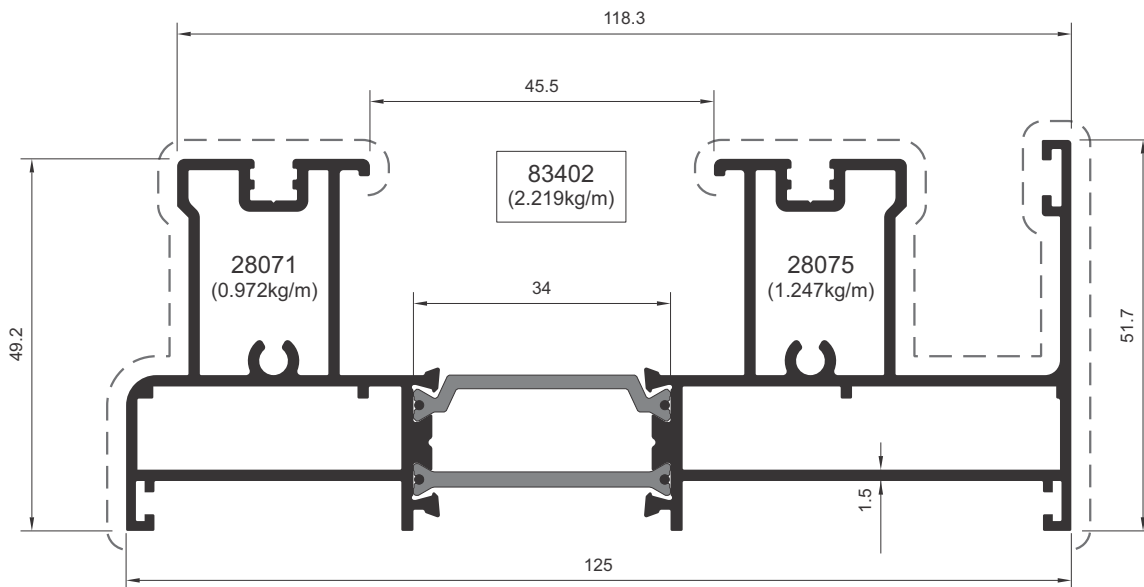

Scale 1:1

All dimensions in mm
Visible area - - - - -

Frame Profile

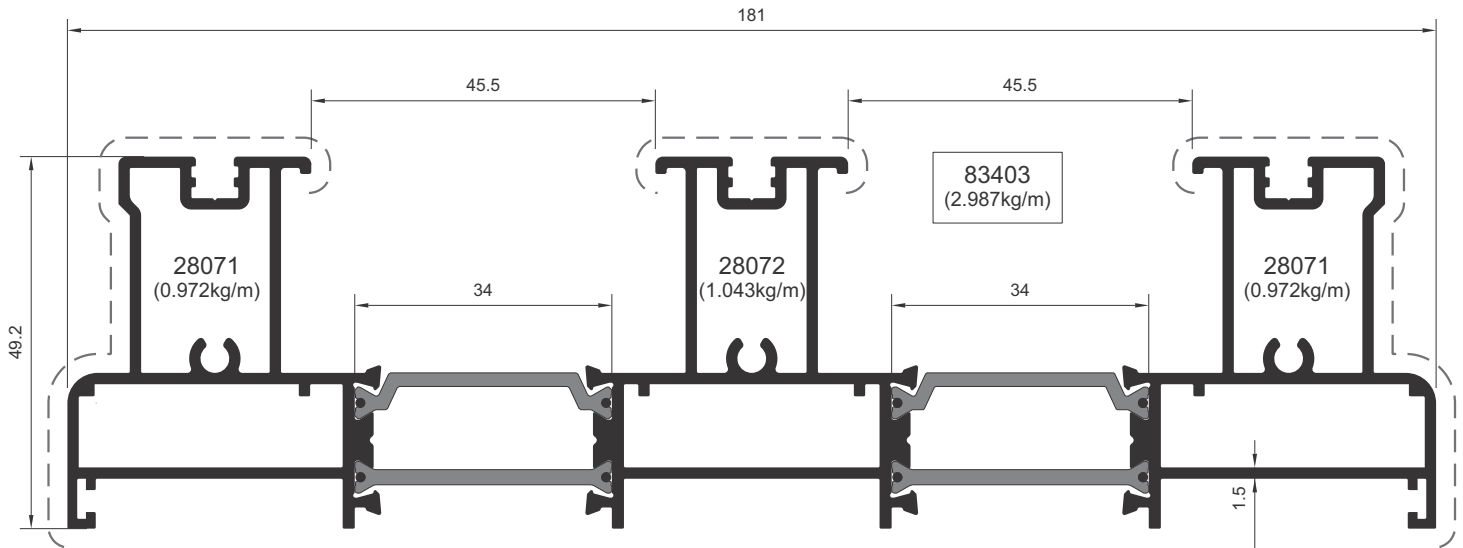

Scale 1:1

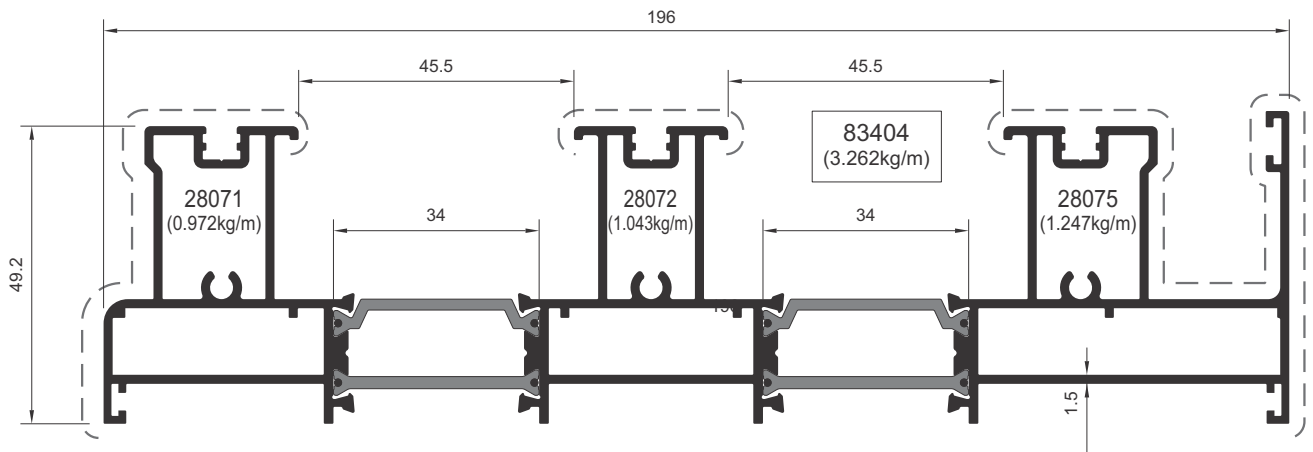

Scale 0.8

All dimensions in mm
Visible area _____

Frame Profile

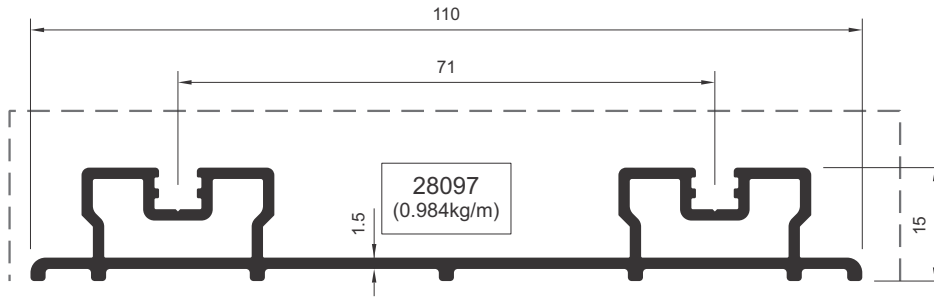

Scale 1:1

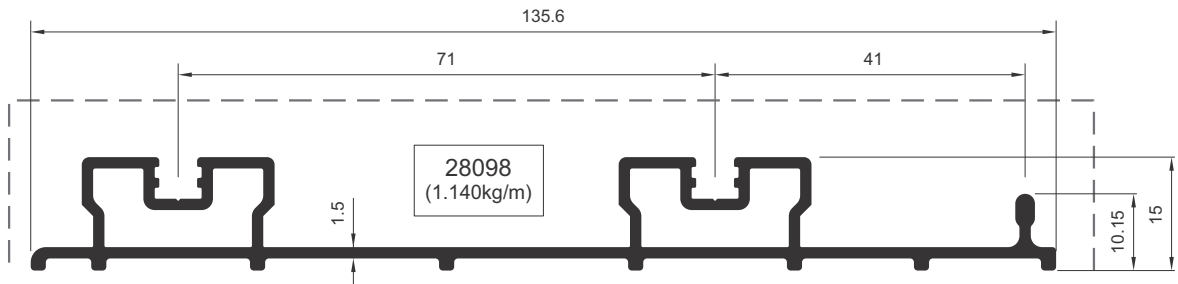

Scale 1:1

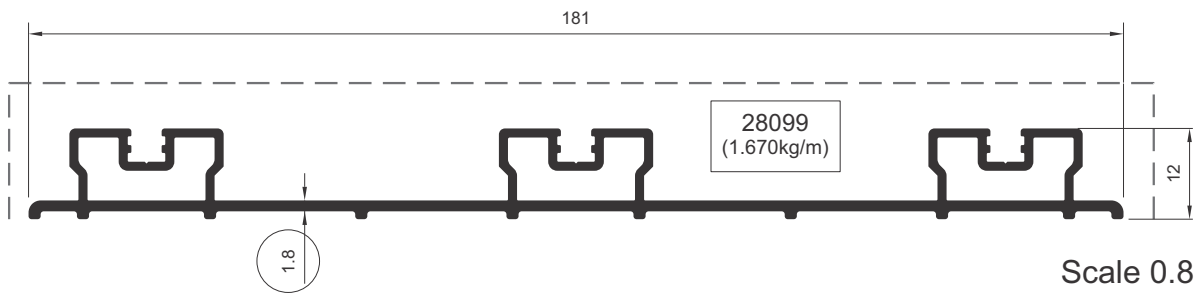

Scale 0.8

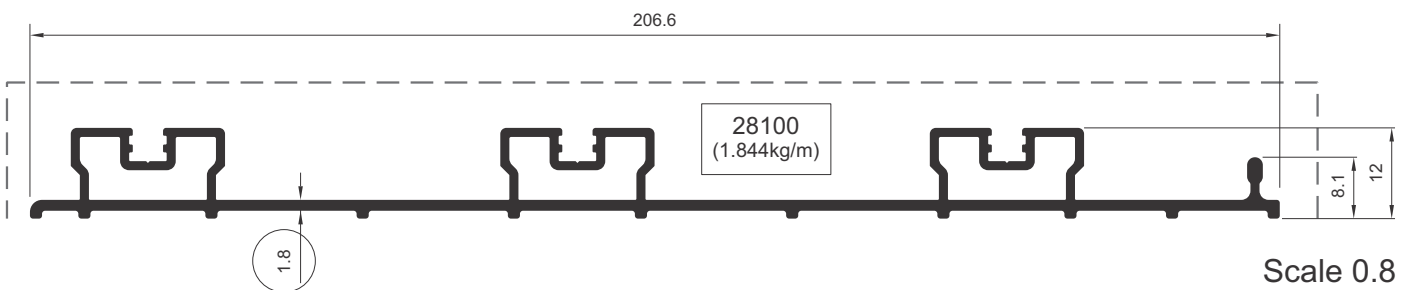

Scale 0.8

All dimensions in mm
Visible area -----

Meeting stile / Add-ons / Fly screen / Sash Profile

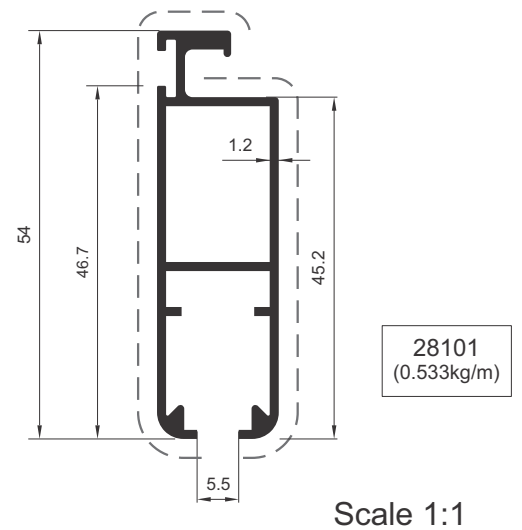
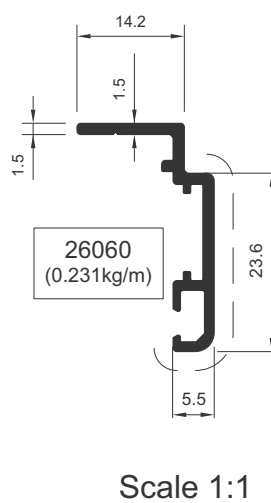
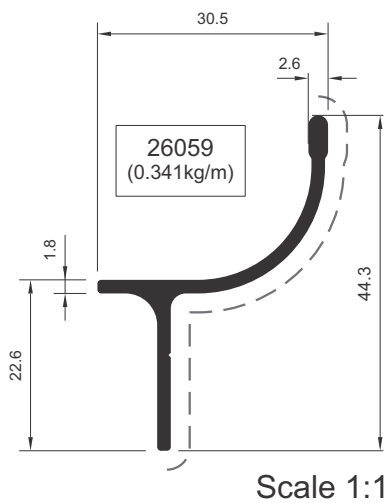
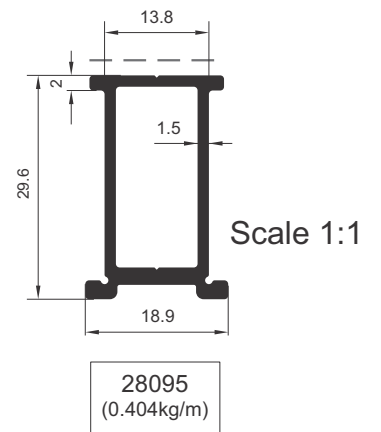
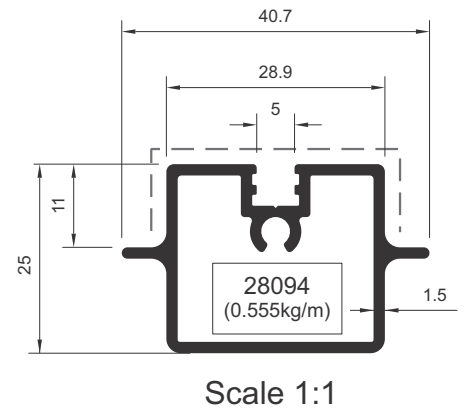
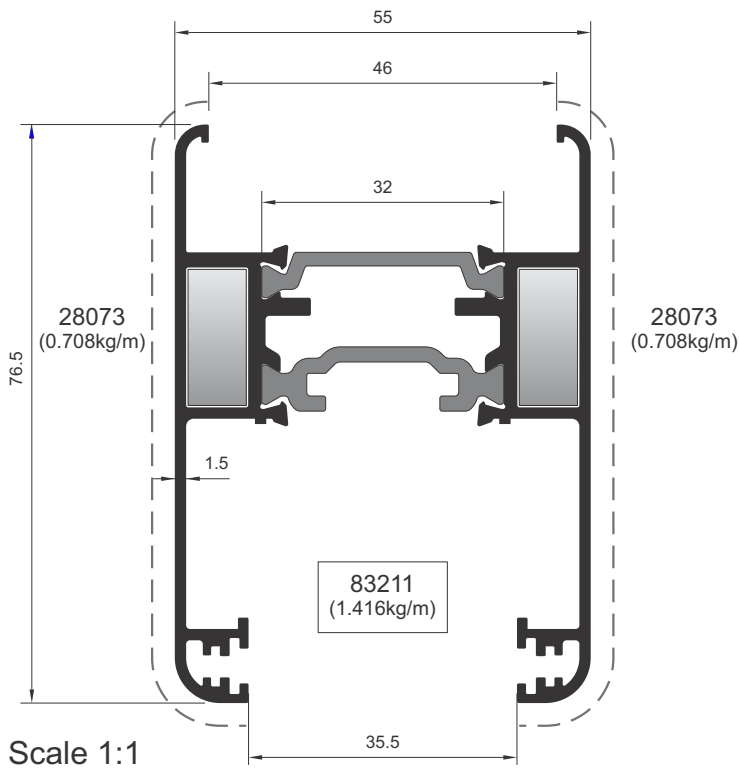

All dimensions in mm
Visible area _____

Handle / Corner / Interlock Profile

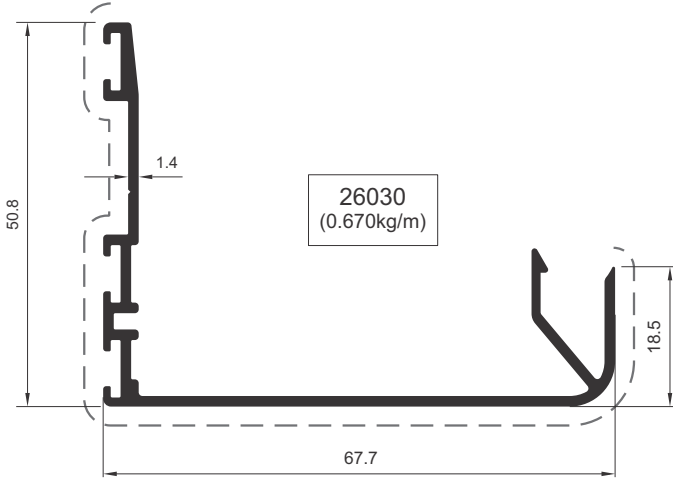

Scale 1:1

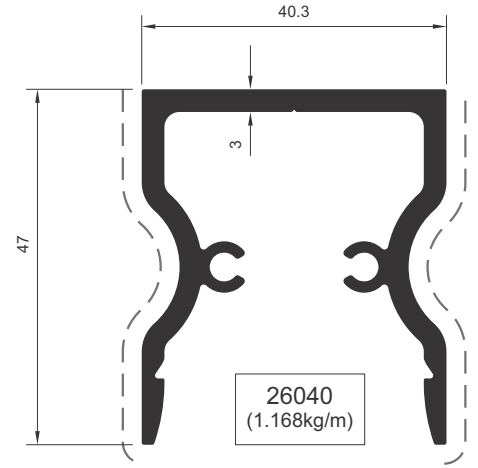

Scale 1:1

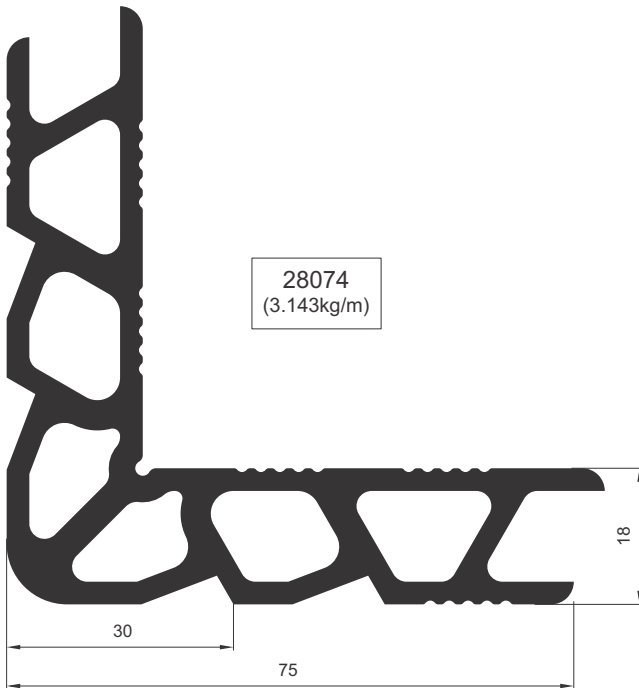

Scale 1:1

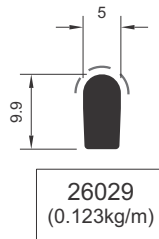

Scale 1:1

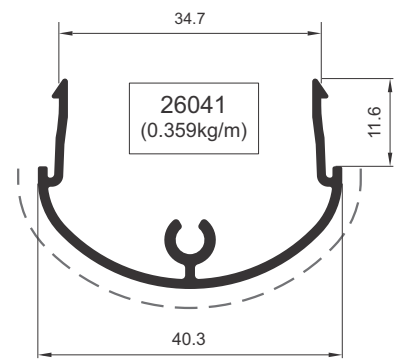

Scale 1:1

All dimensions in mm
Visible area -----

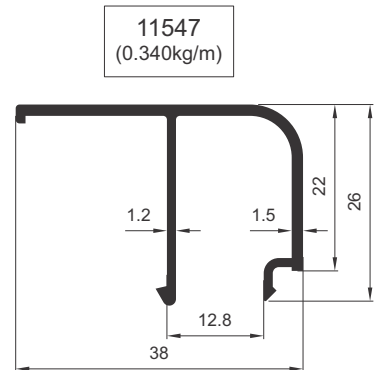
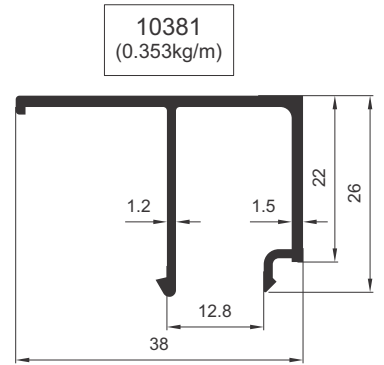
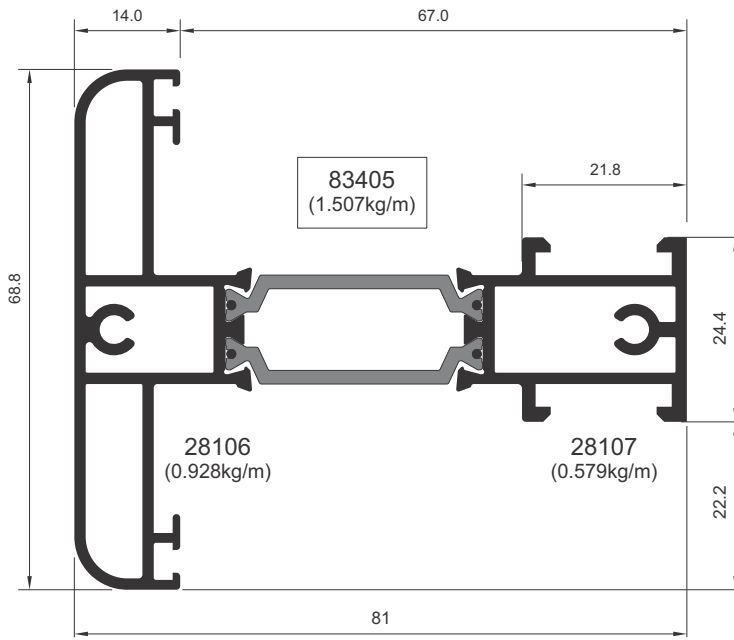

26065
(0.297kg/m)

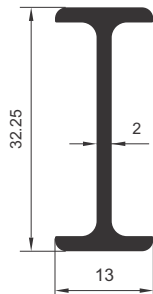

10372
(0.279kg/m)

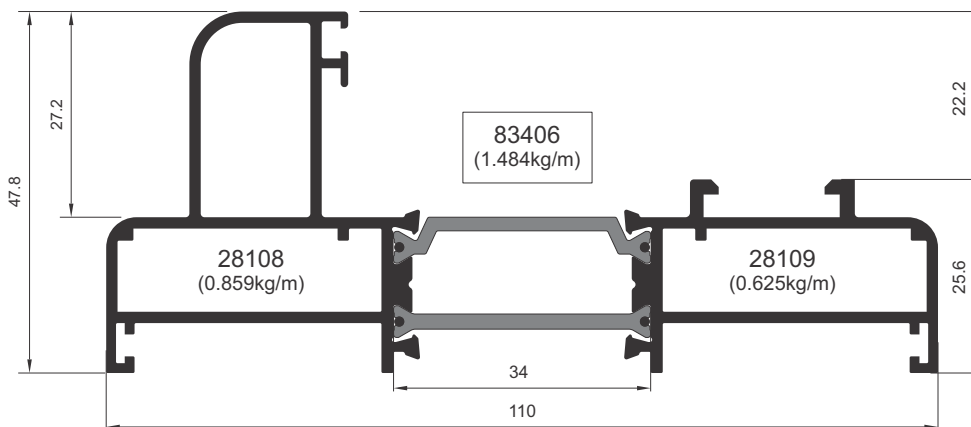
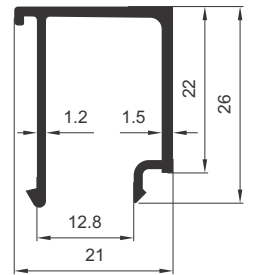



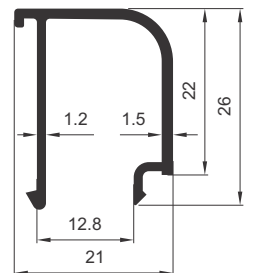



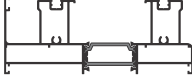
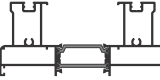
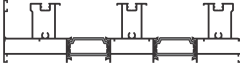
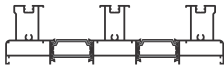

11546
(0.267kg/m)





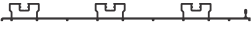
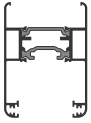

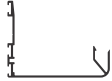



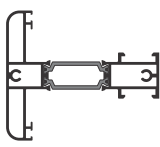
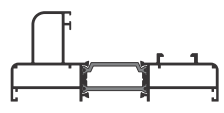

Handwriting practice area with 20 horizontal dashed lines.

PROFILE LIST

| Profile Reference | Child Profile | Profile Section | Page | Weight KG / M | IX cm ⁴ | IY cm ⁴ | WX cm ⁴ | WY cm ⁴ |
|-------------------|-----------------------|---|------|---------------|--------------------|--------------------|--------------------|--------------------|
| 83402 | 28071 + 28075 |  | 06 | 2.219 | 20.40 | 143.38 | 6.85 | 22.90 |
| 83401 | 28071 + 28071 |  | 06 | 1.944 | 18.04 | 98.12 | 6.47 | 17.84 |
| 83404 | 28075 + 28072 + 28071 |  | 07 | 3.262 | 30.51 | 518.42 | 9.97 | 52.74 |
| 83403 | 28071 + 28072 + 28071 |  | 07 | 2.987 | 28.07 | 411.41 | 9.85 | 45.46 |
| 28097 | - |  | 08 | 0.984 | 0.88 | 43.56 | 1.02 | 7.92 |
| 28098 | - |  | 08 | 1.140 | 0.96 | 68.90 | 1.07 | 9.72 |
| 28099 | - |  | 08 | 1.670 | 1.46 | 189.85 | 1.60 | 20.98 |



| Profile Reference | Child Profile | Profile Section | Page | Weight KG / M | IX cm ⁴ | IY cm ⁴ | WX cm ⁴ | WY cm ⁴ |
|-------------------|---------------|---|------|---------------|--------------------|--------------------|--------------------|--------------------|
| 28100 | - |  | 08 | 1.844 | 1.53 | 255.91 | 1.63 | 24.12 |
| 83211 | 28073 + 28073 |  | 09 | 1.416 | 26.27 | 28.64 | 6.33 | 10.41 |
| 28094 | - |  | 09 | 0.558 | 1.5 | 2.44 | 1.11 | 1.2 |
| 28095 | - |  | 09 | 0.558 | 1.67 | 0.51 | 1.07 | 0.54 |
| 26030 | - |  | 10 | 0.670 | 5.74 | 16.4 | 1.54 | 3.96 |
| 26040 | - |  | 10 | 1.168 | 8.48 | 10.05 | 2.89 | 4.98 |
| 26041 | - |  | 10 | 0.359 | 0.82 | 2.45 | 0.83 | 1.49 |







| Profile Reference | Child Profile | Profile Section | Page | Weight KG / M | IX cm ⁴ | IY cm ⁴ | WX cm ⁴ | WY cm ⁴ |
|-------------------|---------------|---|------|---------------|--------------------|--------------------|--------------------|--------------------|
| 28101 | - |  | 09 | 0.533 | 5.75 | 0.77 | 2.10 | 0.89 |
| 28074 | - |  | 10 | 3.143 | 55.24 | 55.24 | 10.21 | 10.21 |
| 26059 | - |  | 09 | 0.341 | 1.45 | 1.1 | 0.64 | 0.68 |
| 26060 | - |  | 09 | 0.231 | 0.86 | 0.18 | 0.48 | 0.13 |
| 26029 | - |  | 10 | 0.123 | 0.03 | 0.01 | 0.06 | 0.04 |
| 83405 | 28106 + 28107 |  | 11 | 1.504 | 13.85 | 52.44 | 4.03 | 10.79 |
| 83406 | 28108 + 28109 |  | 11 | 1.484 | 9.09 | 71.12 | 2.91 | 12.03 |



| Profile Reference | Child Profile | Profile Section | Page | Weight KG / M | IX cm ⁴ | IY cm ⁴ | WX cm ⁴ | WY cm ⁴ |
|-------------------|---------------|---|------|---------------|--------------------|--------------------|--------------------|--------------------|
| 26065 | - |  | 11 | 0.297 | 1.58 | 0.07 | 0.98 | 0.11 |
| 10372 | - |  | 11 | 0.279 | 0.78 | 0.60 | 0.48 | 0.51 |
| 10381 | - |  | 11 | 0.353 | 0.97 | 1.57 | 0.53 | 0.64 |
| Optional 11546 | - |  | 11 | 0.267 | 0.78 | 0.56 | 0.46 | 0.50 |
| Optional 11547 | - |  | 11 | 0.340 | 0.94 | 1.48 | 0.52 | 0.61 |
| | | | | | | | | |
| | | | | | | | | |

Handwriting practice area with 20 horizontal dashed lines.

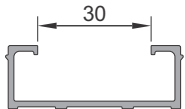
GASKET ACCESSORIES



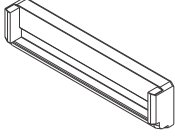
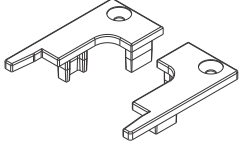
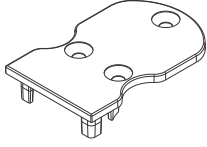
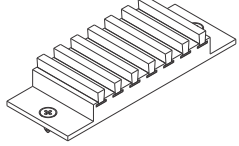
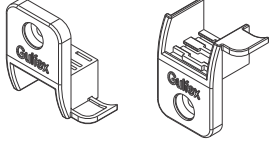
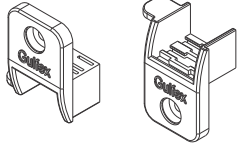

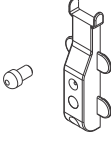
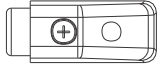
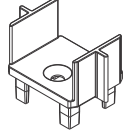

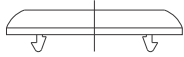
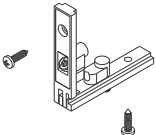
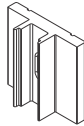
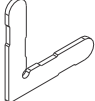
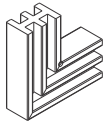
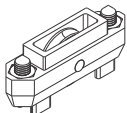
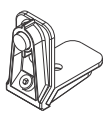
| Gasket / Accessories Reference | Section | Description | Unit |
|--------------------------------|---|------------------------------------|--------------|
| AC 100 |  | Gasket for interlock | Linear Meter |
| AC 101 |  | Glazing gasket (01) | Linear Meter |
| AC 102 |  | Glazing gasket (02) | Linear Meter |
| AC 103 |  | U-gasket for Meeting stile profile | Linear Meter |
| AC 104 |  | Gasket for flyscreen | Linear Meter |
| AC 105 |  | Gasket for flyscreen net | Linear Meter |
| AC 106 |  | Decorative gasket for frame | Linear Meter |
| AC 107 |  | Q-Ion foam for frame | Linear Meter |
| AC 108 |  | Brush 6mm | Linear Meter |
| AC 109 |  | Brush 8mm | Linear Meter |



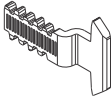

| Gasket / Accessories Reference | Section | Description | Unit |
|--------------------------------|---|--|--------------|
| AC 110 |  | Brush 12mm | Linear Meter |
| AC 111 |  | Gasket for windows with Fixed glass | Linear Meter |
| AC 112 |  | Gasket for Fixed glass on glazing beam 21mm for 40mm glass | Linear Meter |
| AC 113 |  | Gasket for Fixed glass on glazing beam 38mm for 24mm glass | Linear Meter |
| PVC 101 |  | PVC - Sash Adapter | Linear Meter |
| PVC 102 |  | PVC - Interlock | Linear Meter |
| PVC 103 |  | PVC - Frame Adapter | Linear Meter |
| | | | |
| | | | |
| | | | |

| Gasket / Accessories Reference | Section | Description | Unit |
|--------------------------------|---|----------------------------------|--------|
| AC 1001 |  | Plastic spacer for roller | Pieces |
| AC 1002 |  | Plastic cover for PVC Interlock | Pieces |
| AC 1003 |  | Plastic Cover for Handle profile | Pieces |
| AC 1004 |  | Central seal | Pieces |
| AC 1005 |  | Cover Interlock (Right) | Pieces |
| AC 1006 |  | Cover Interlock (Left) | Pieces |
| AC 1007 |  | Screw cover | Pieces |
| AC 1008 |  | Bumper (SET) | Pieces |
| AC 1009 |  | Sash stopper | Pieces |
| AC 1010 |  | Cover for Meeting stile profile | Pieces |

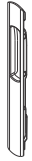
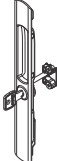
| Gasket / Accessories Reference | Section | Description | Unit |
|--------------------------------|---|---------------------------------|--------|
| AC 1017 |  | Water drainage Cover | Pieces |
| AC 1018 |  | Sash Connection Corner | Pieces |
| AC 1019 |  | Plastic spacer for Inline lock | Pieces |
| AC 1020 |  | Alignment Corner (5 X 1 mm) | Pieces |
| AC 1021 |  | Corner for Fly screen sash | Pieces |
| AC 1022 |  | Roller for Fly screen | Pieces |
| AC 1023 |  | Frame Connection Corner (0365s) | Pieces |
| | | | |
| | | | |
| | | | |

| Gasket / Accessories Reference | Section | Description | Unit |
|--------------------------------|---|-------------------------------------|--------|
| AC 1100 |  | Self tapping screw (3,5 X 13mm) | Pieces |
| AC 1101 |  | Self tapping screw (4,2 X 13mm) | Pieces |
| AC 1102 |  | Self tapping screw (4,2 X 13 mm) | Pieces |
| AC 1103 |  | Self tapping screw (4,8 X 13mm) | Pieces |
| AC 1104 |  | Self tapping screw (4,2 X 19 mm) | Pieces |
| | | | |
| | | | |
| | | | |
| | | | |
| | | | |

| Gasket / Accessories Reference | Section | Description | Unit |
|--------------------------------|---|--|--------|
| AC 2000 |  | DOUBLE WHEEL (PA) 100KG SASH | Pieces |
| AC 2001 |  | DOUBLE WHEEL (DERLIN) 130KG SASH | Pieces |
| AC 2002 |  | LOCK OLE WINDOWS ONLY | Pieces |
| AC 2003 |  | LOCK OLE TOP | Pieces |
| AC 2004 |  | Latch base | Pieces |
| AC 2005 |  | Latch | Pieces |
| AC 2006 |  | Locking point | Pieces |
| AC 2007 |  | LOCK OLE TOP + KEY | Pieces |
| AC 2008 |  | LOCK OLE TOP (for outside without lock) | Pieces |
| AC 2009 |  | LOCK OLE TOP (for outside with key) | Pieces |

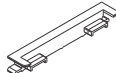
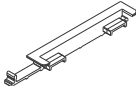
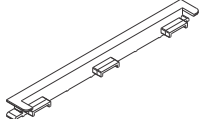
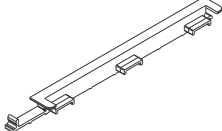
| Gasket / Accessories Reference | Section | Description | Unit |
|--------------------------------|---|---|--------|
| AC 2010 |  | EXTERIOR HANDLE | Pieces |
| AC 2011 |  | EXTERIOR HANDLE + KEY | Pieces |
| AC 2012 |  | ROUND HANDLE (OLE' & OLE+) WINDOWS ONLY | Pieces |
| AC 2013 |  | ROUND HANDLE (OLE' TOP) | Pieces |
| AC 2014 |  | END COVER FOR LOW DOUBLE DRIVER (28097) | Pieces |
| AC 2015 |  | END COVER FOR LOW DOUBLE DRIVER (28098) | Pieces |
| AC 2016 |  | END COVER FOR LOW DOUBLE DRIVER (28099) | Pieces |
| AC 2017 |  | END COVER FOR LOW DOUBLE DRIVER (28100) | Pieces |
| | | | |
| | | | |

GLAZING TYPOLOGIE

Typologie
Double Glazing Beam*

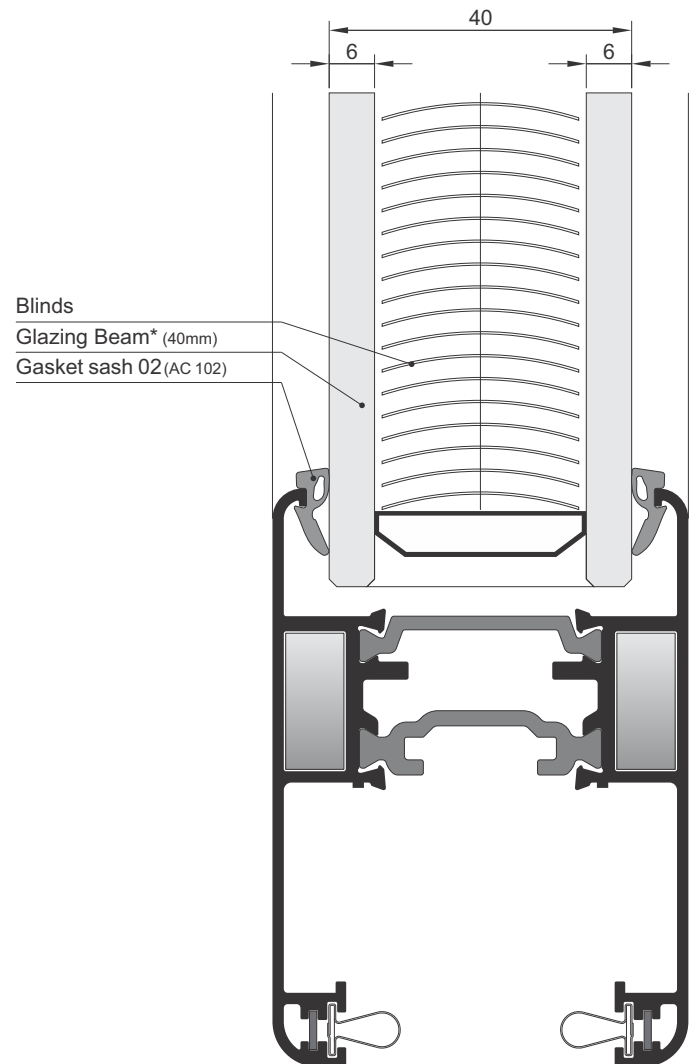
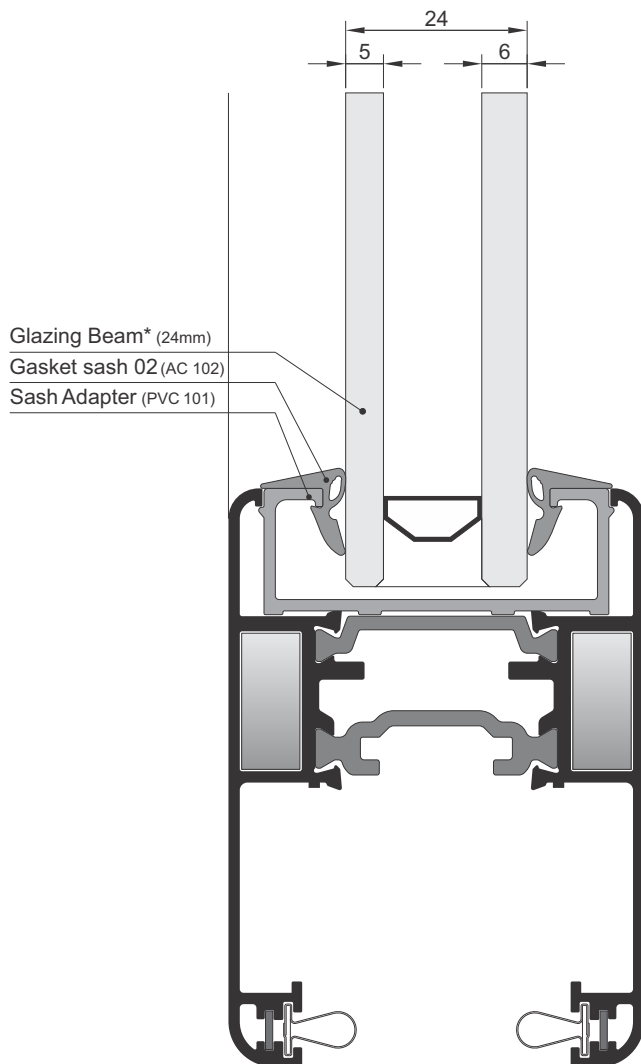

Typologie
Double Glazing Beam*

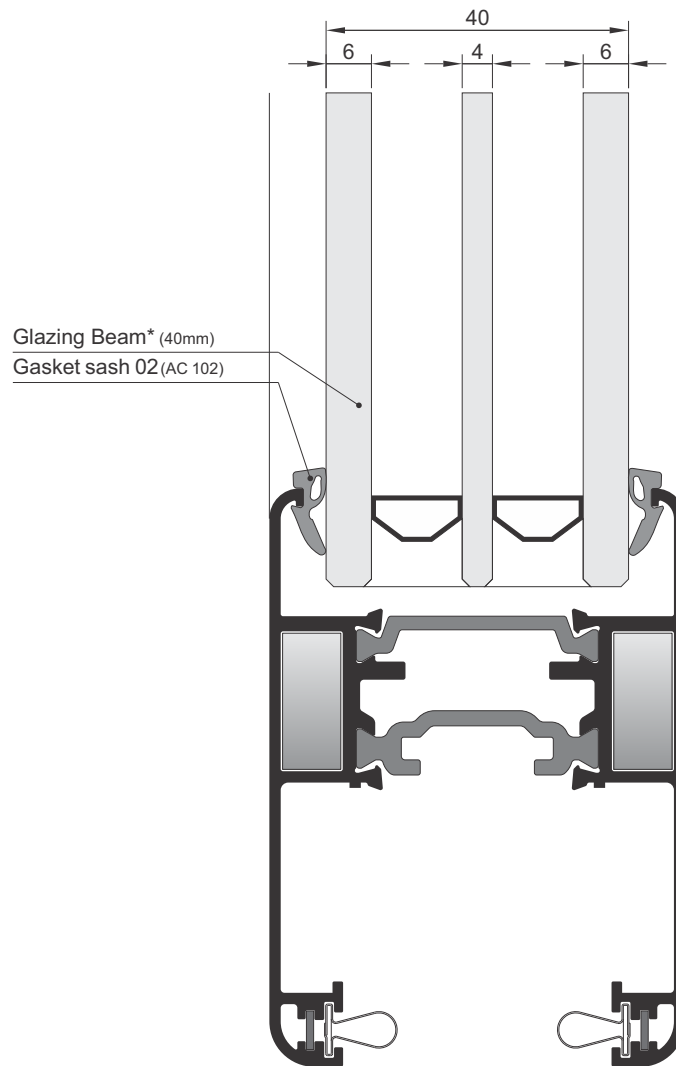

Handwriting practice area with 20 horizontal dashed lines.

TYPOLOGIE

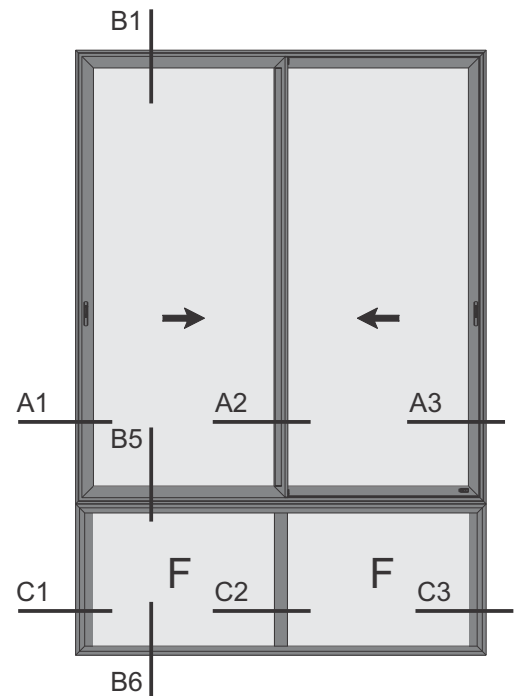
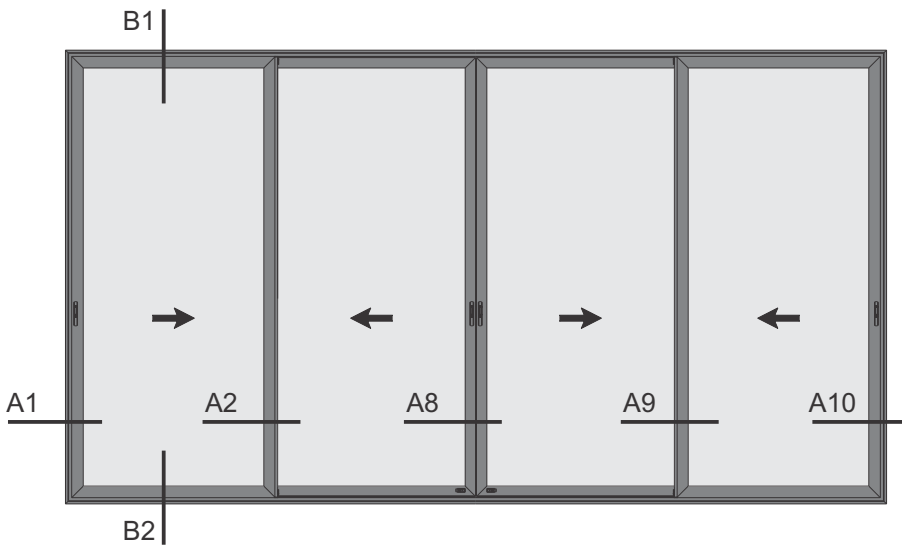
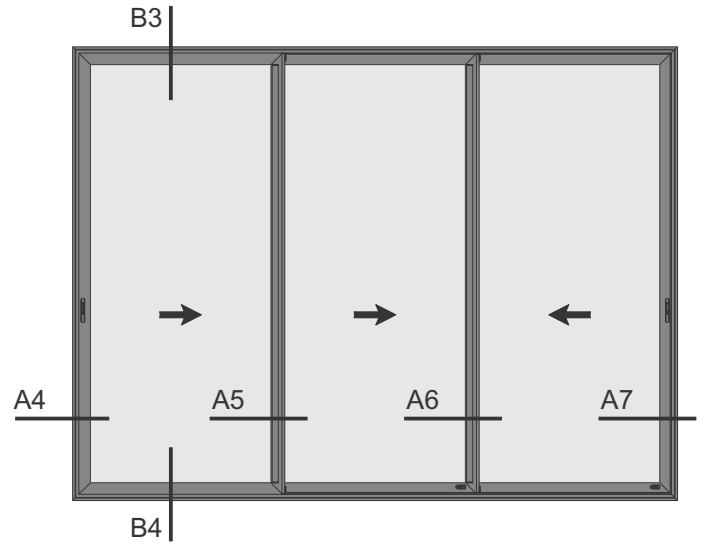
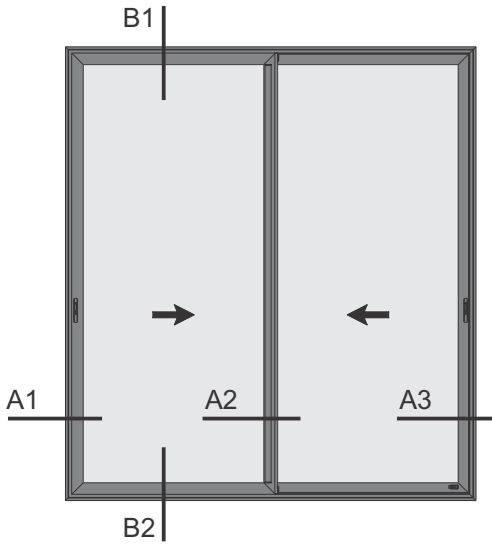

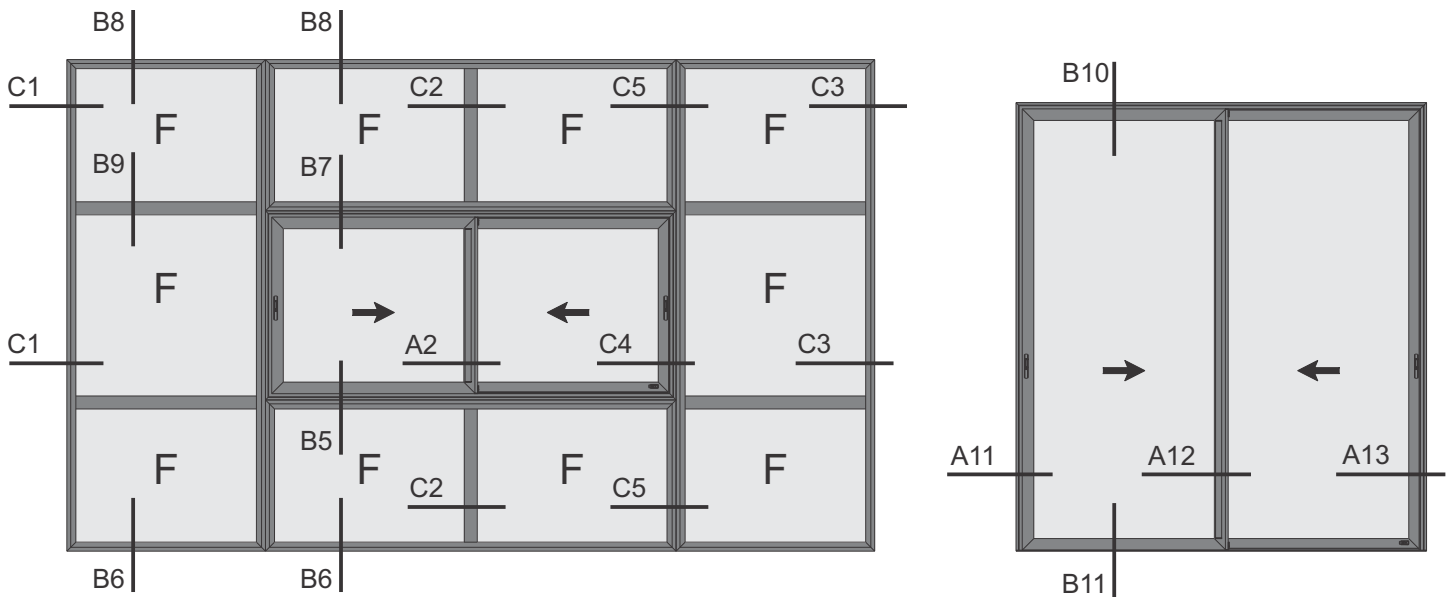
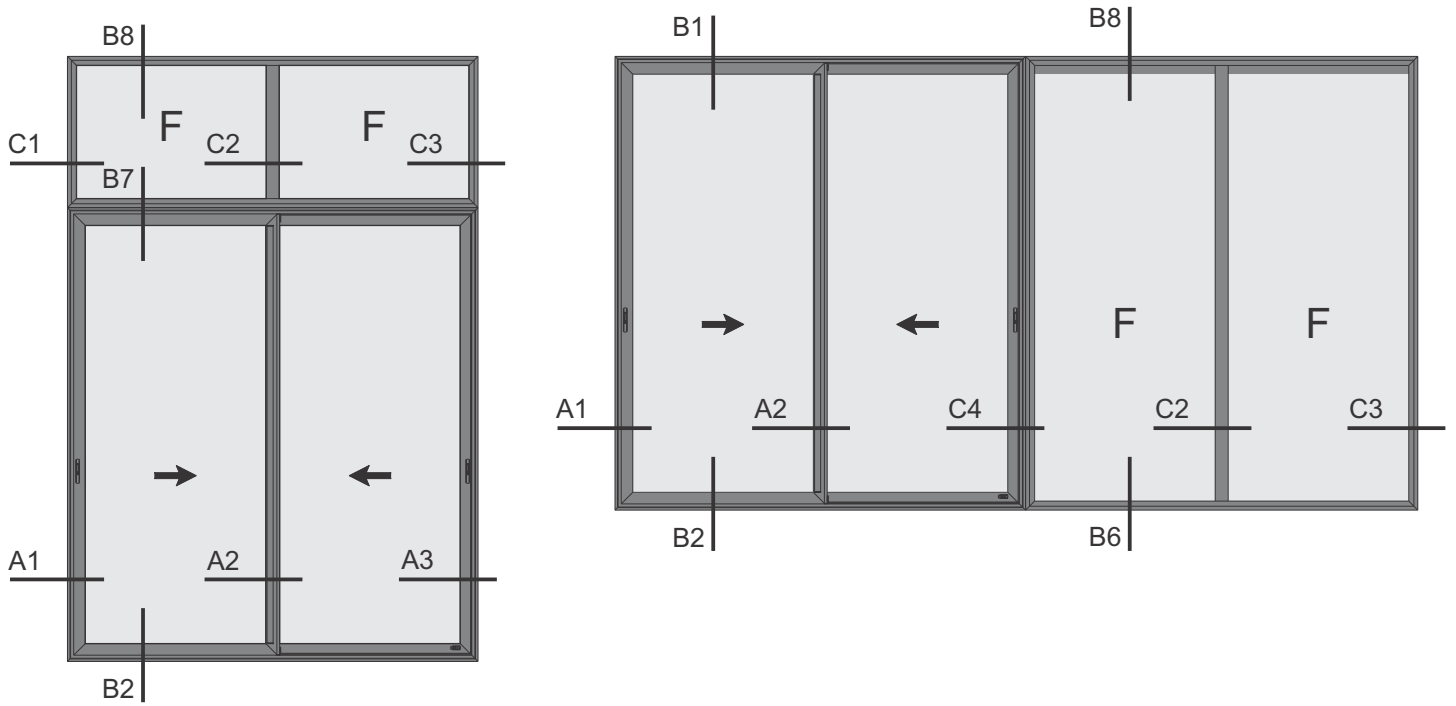

Handwriting practice area with 20 horizontal dashed lines.

SECTIONS

New Sliding System
Detail - A1

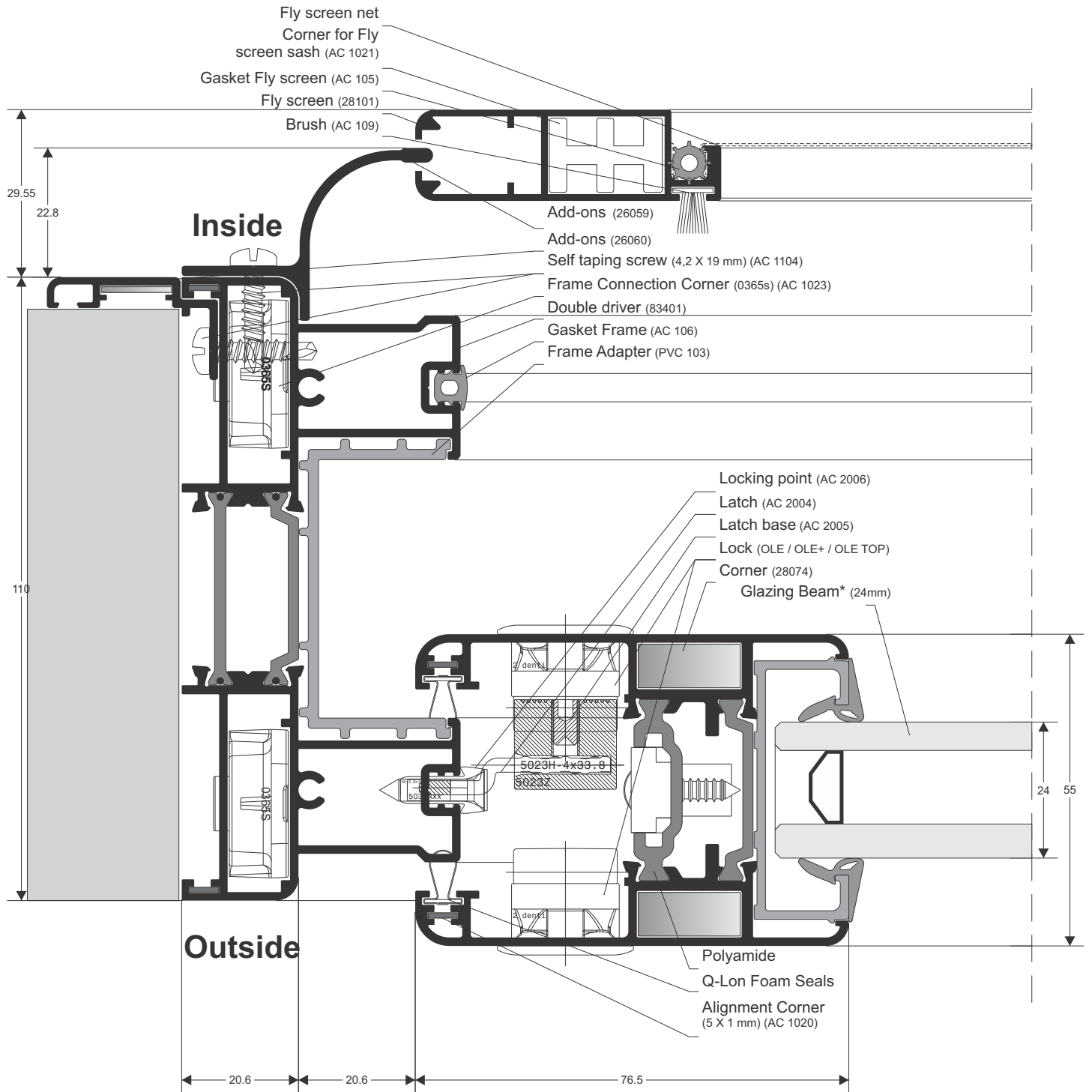

New Sliding System
Detail - A2

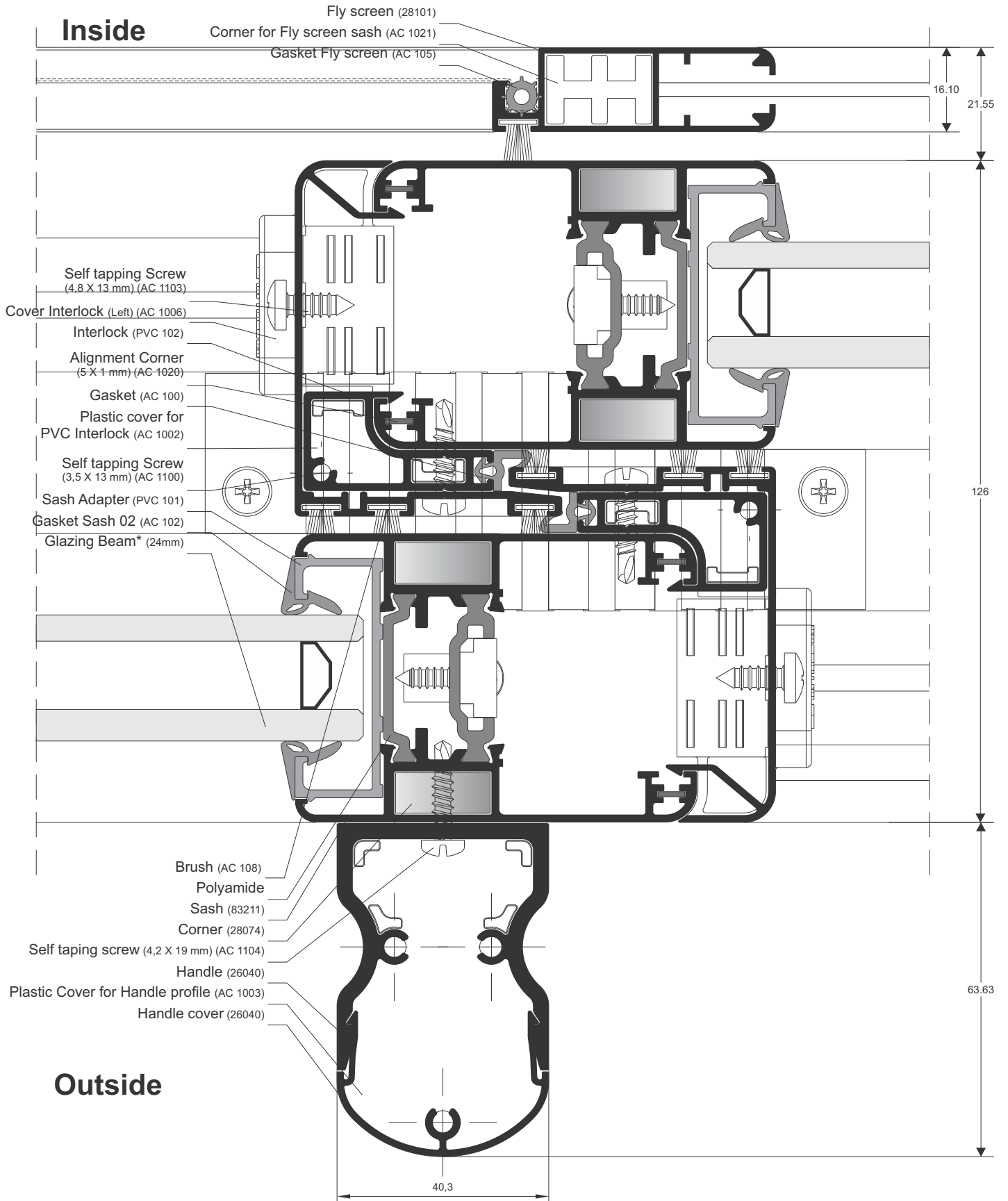

New Sliding System
Detail - A3

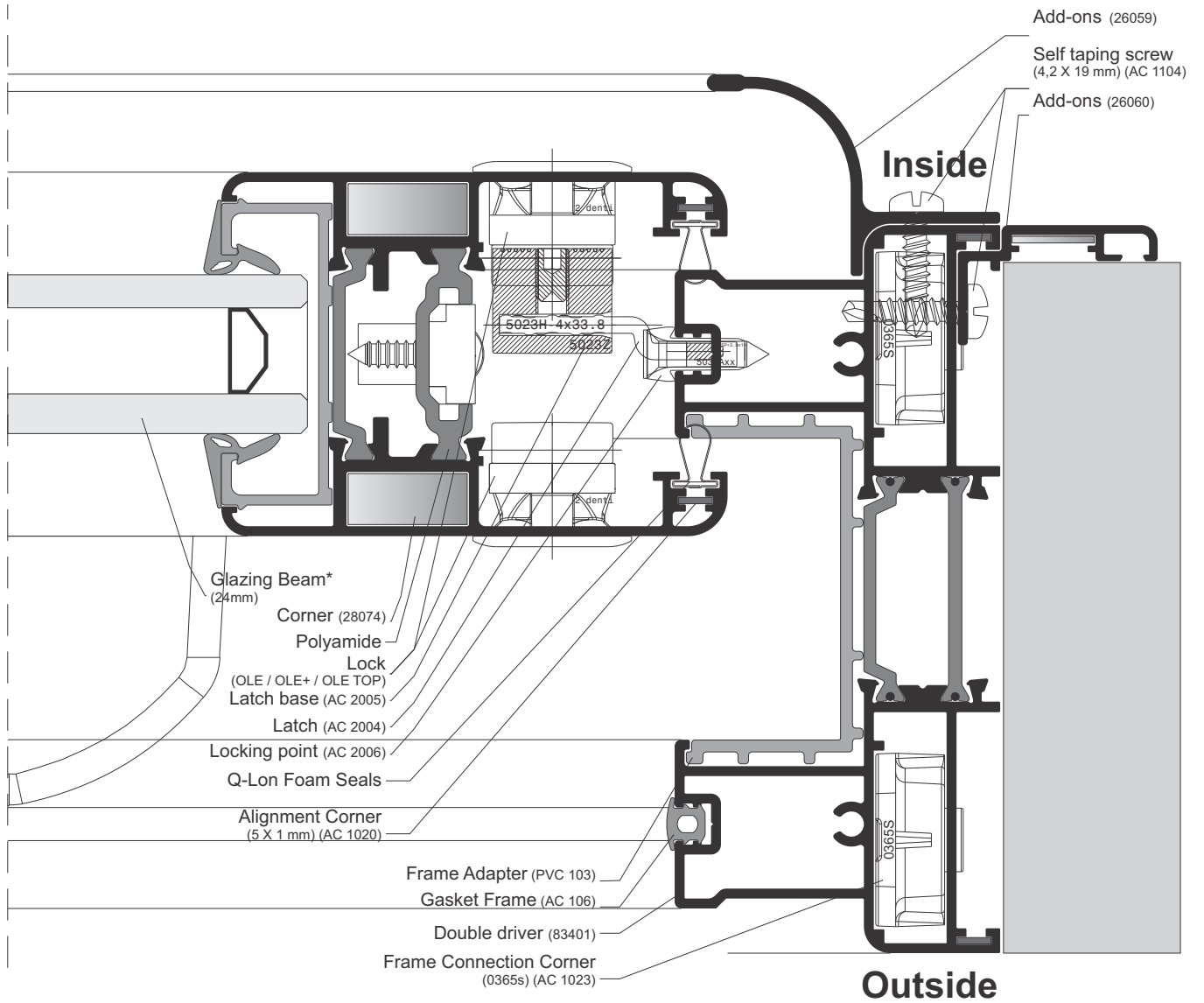

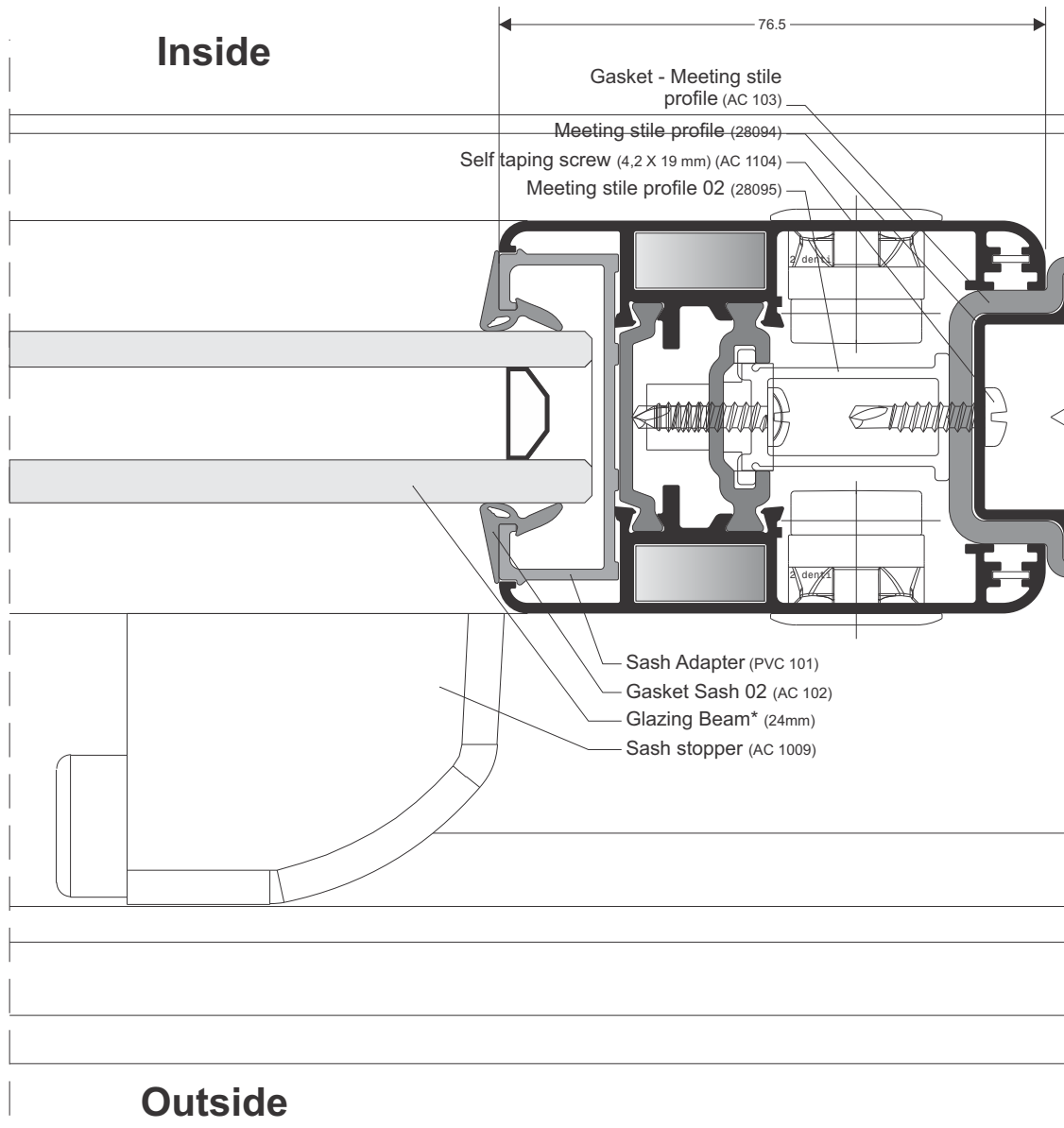

New Sliding System
Detail - A8

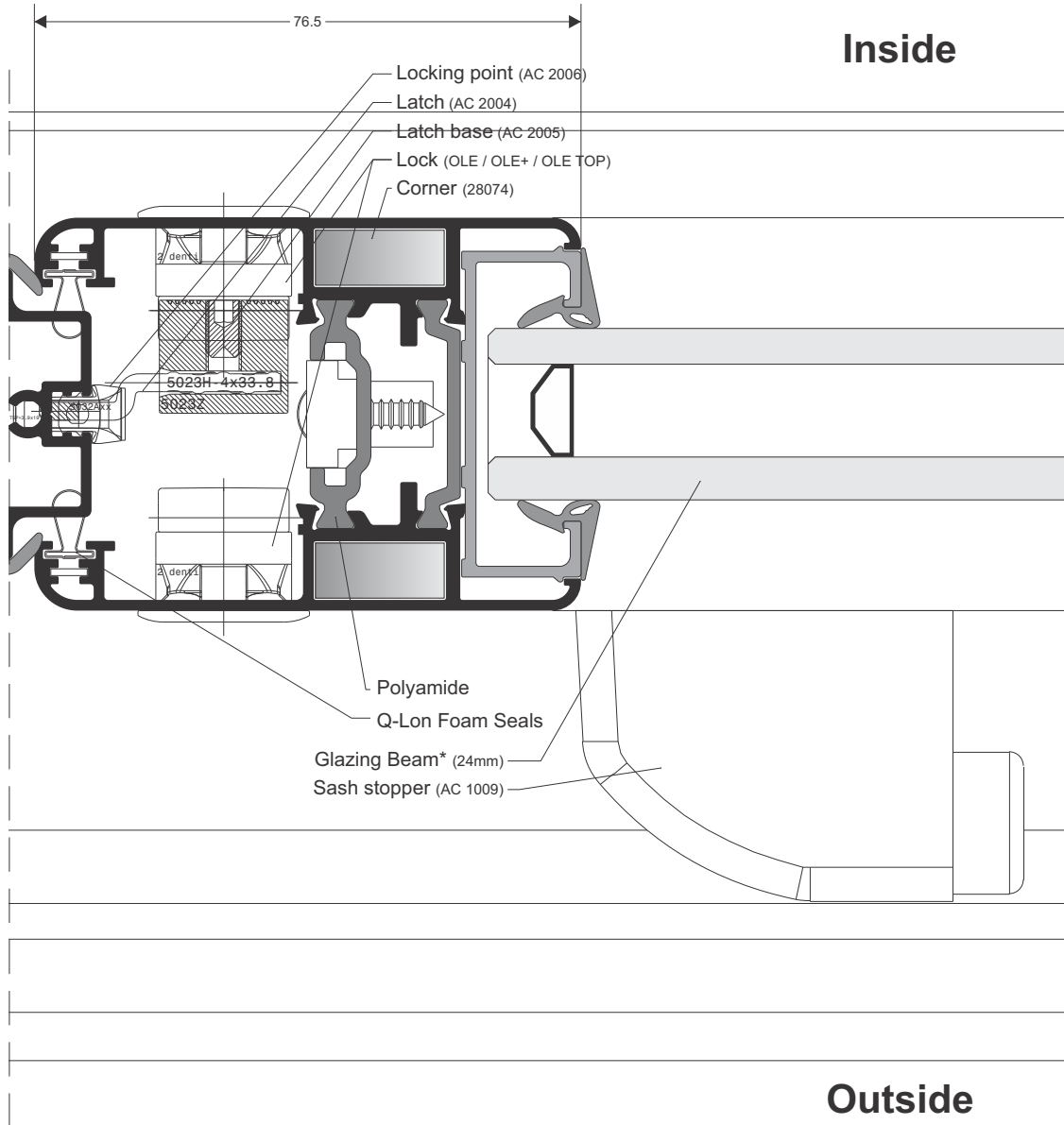

New Sliding System
Detail - A9

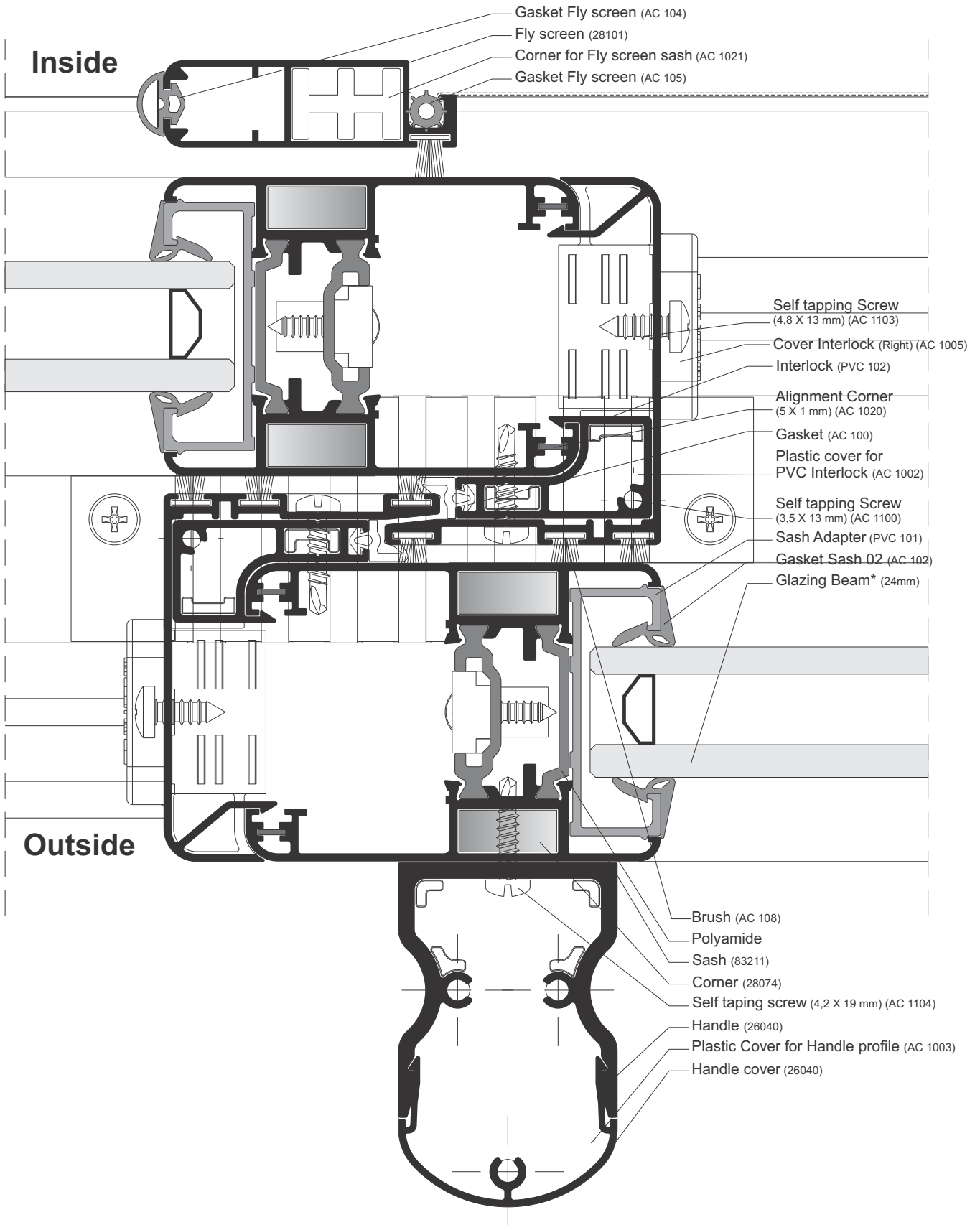

New Sliding System
Detail - A10

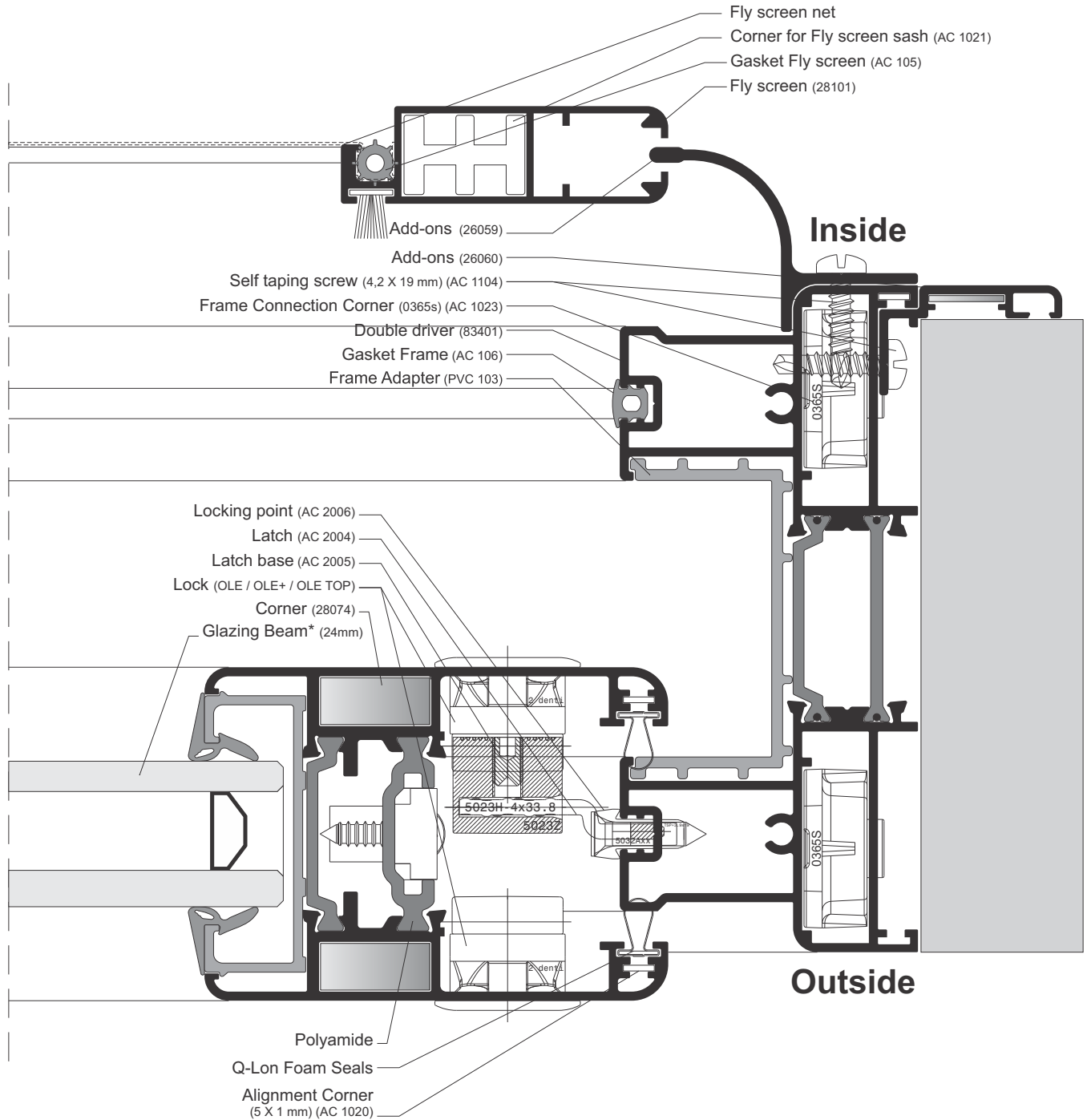

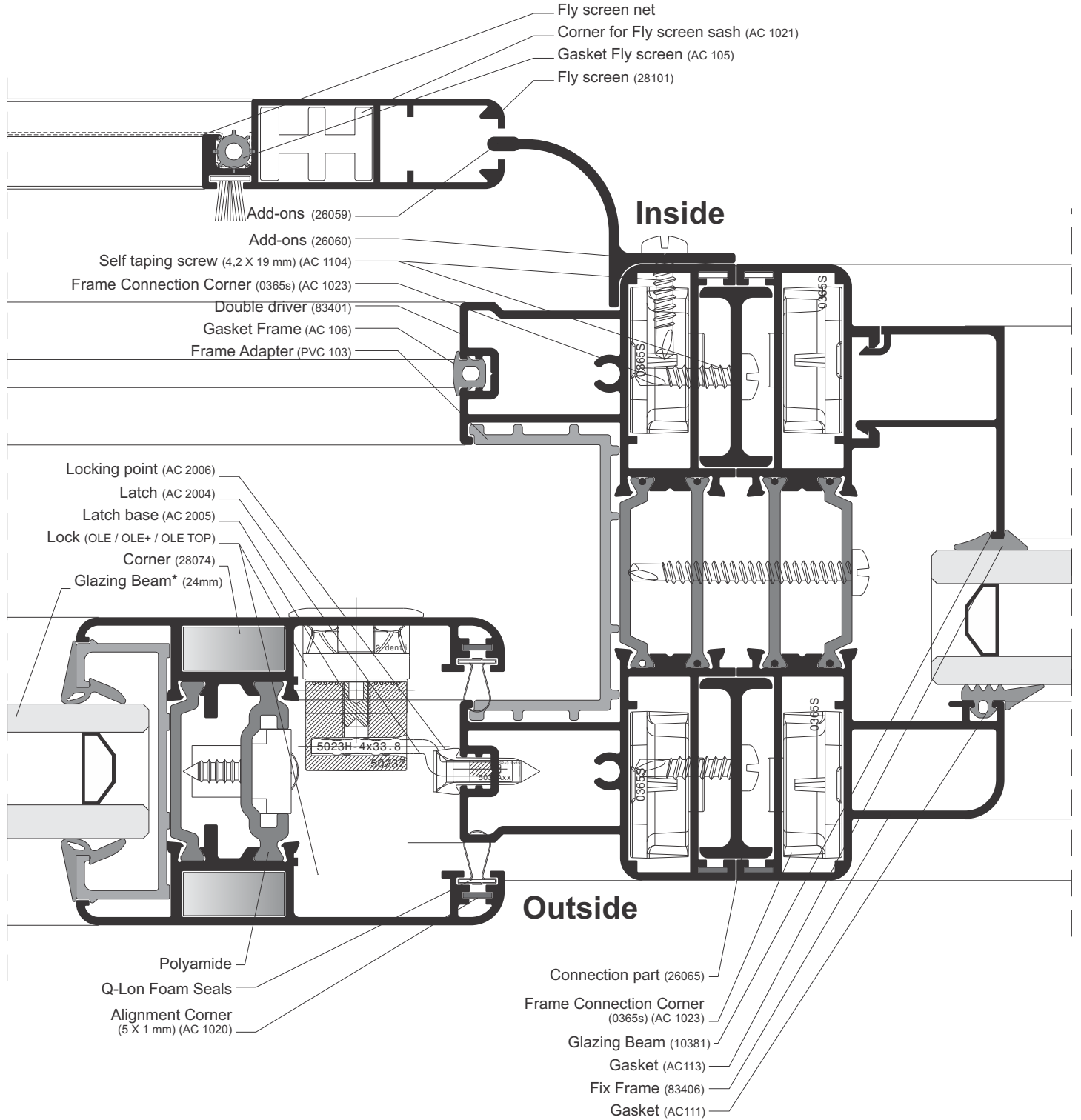

New Sliding System
Detail - C1

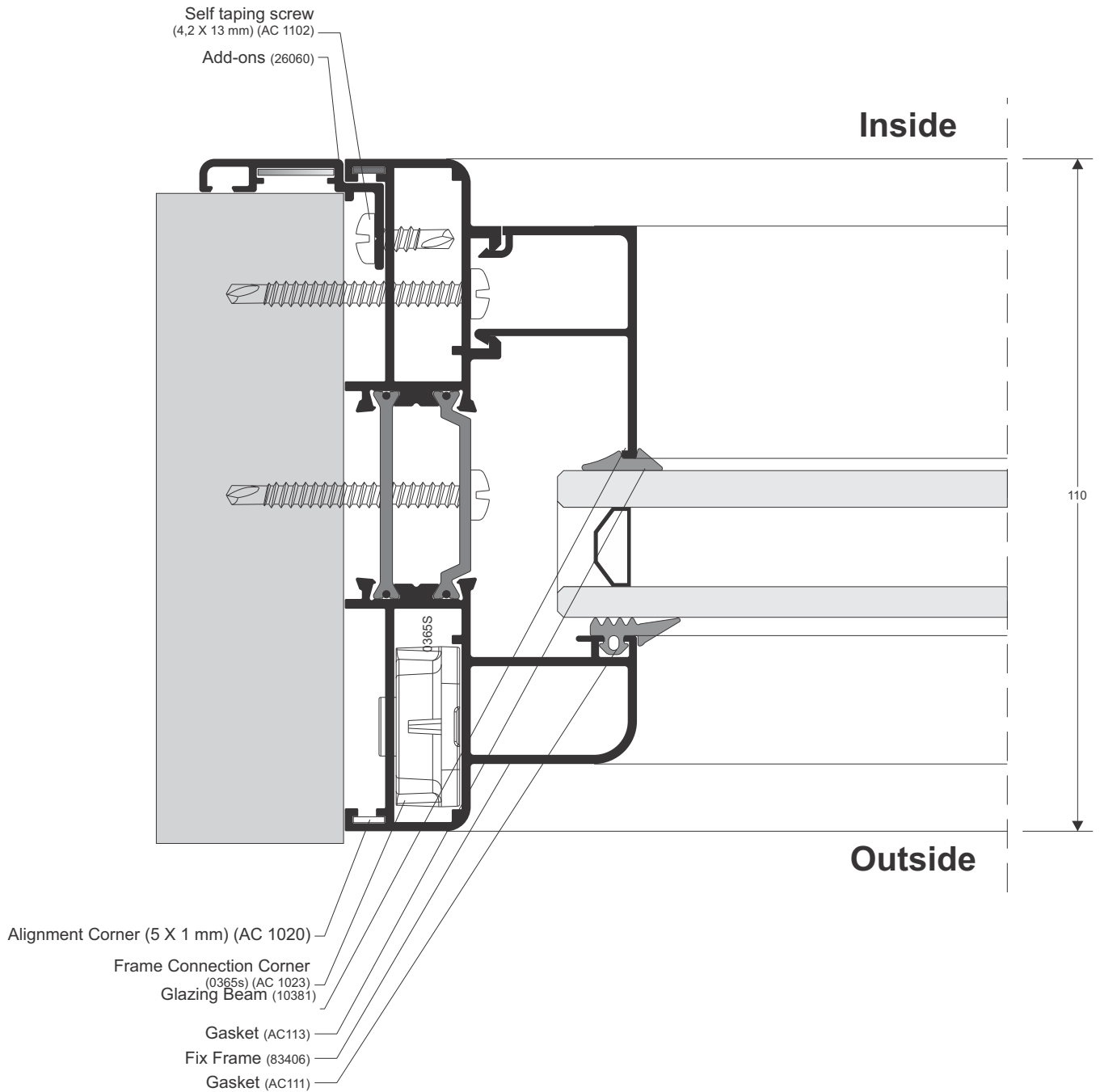

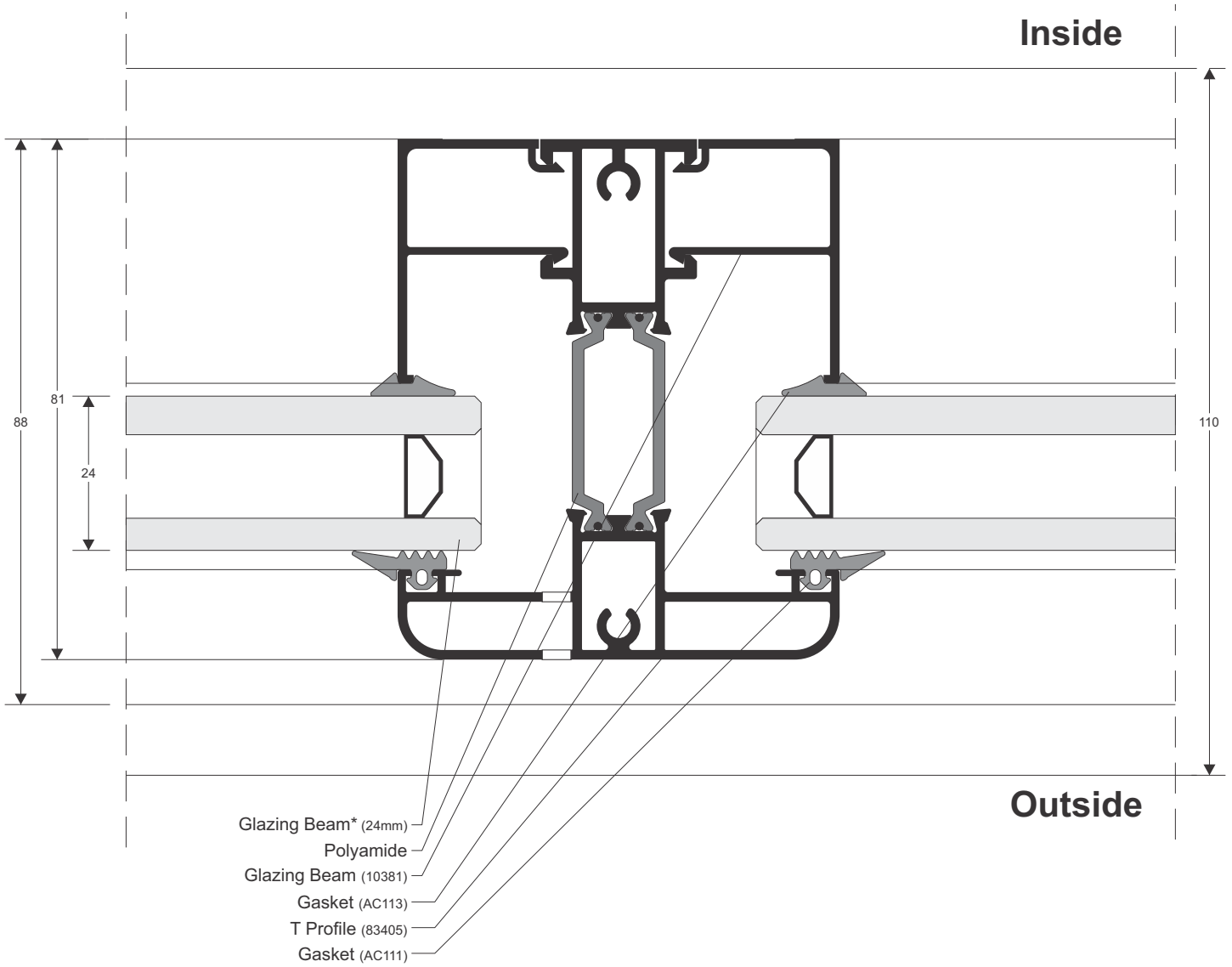

New Sliding System
Detail - C5

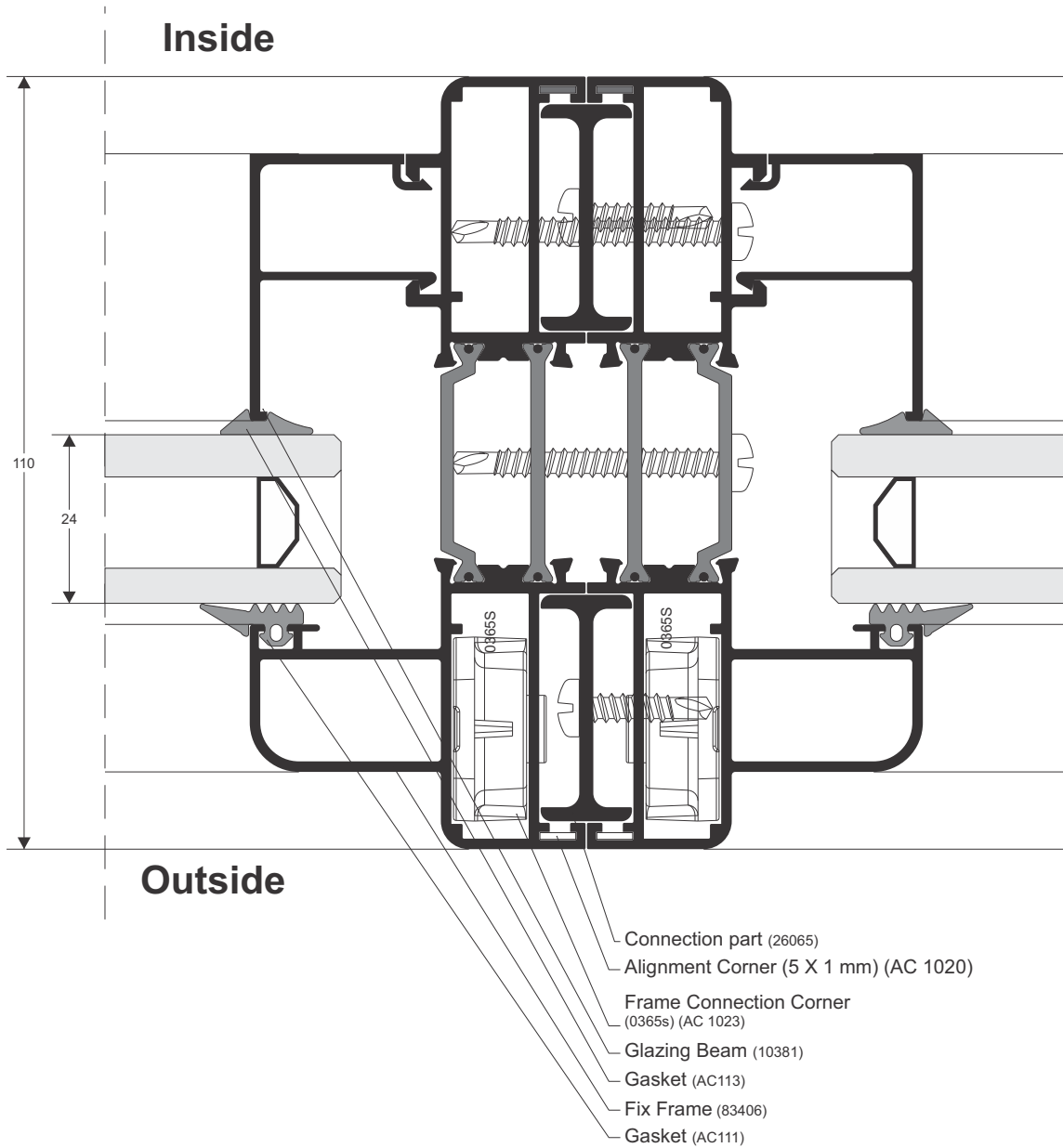

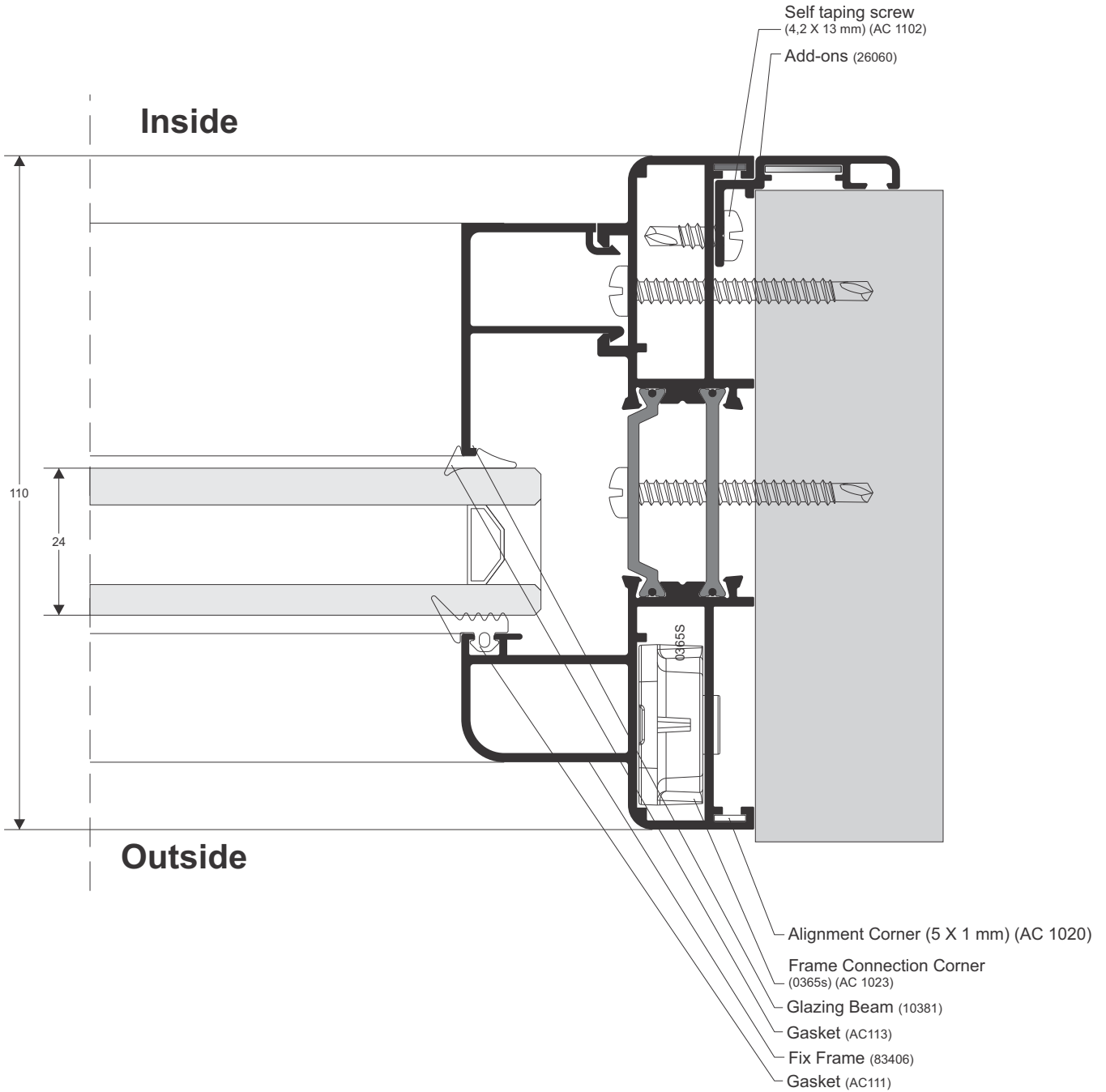

New Sliding System
Detail - C1

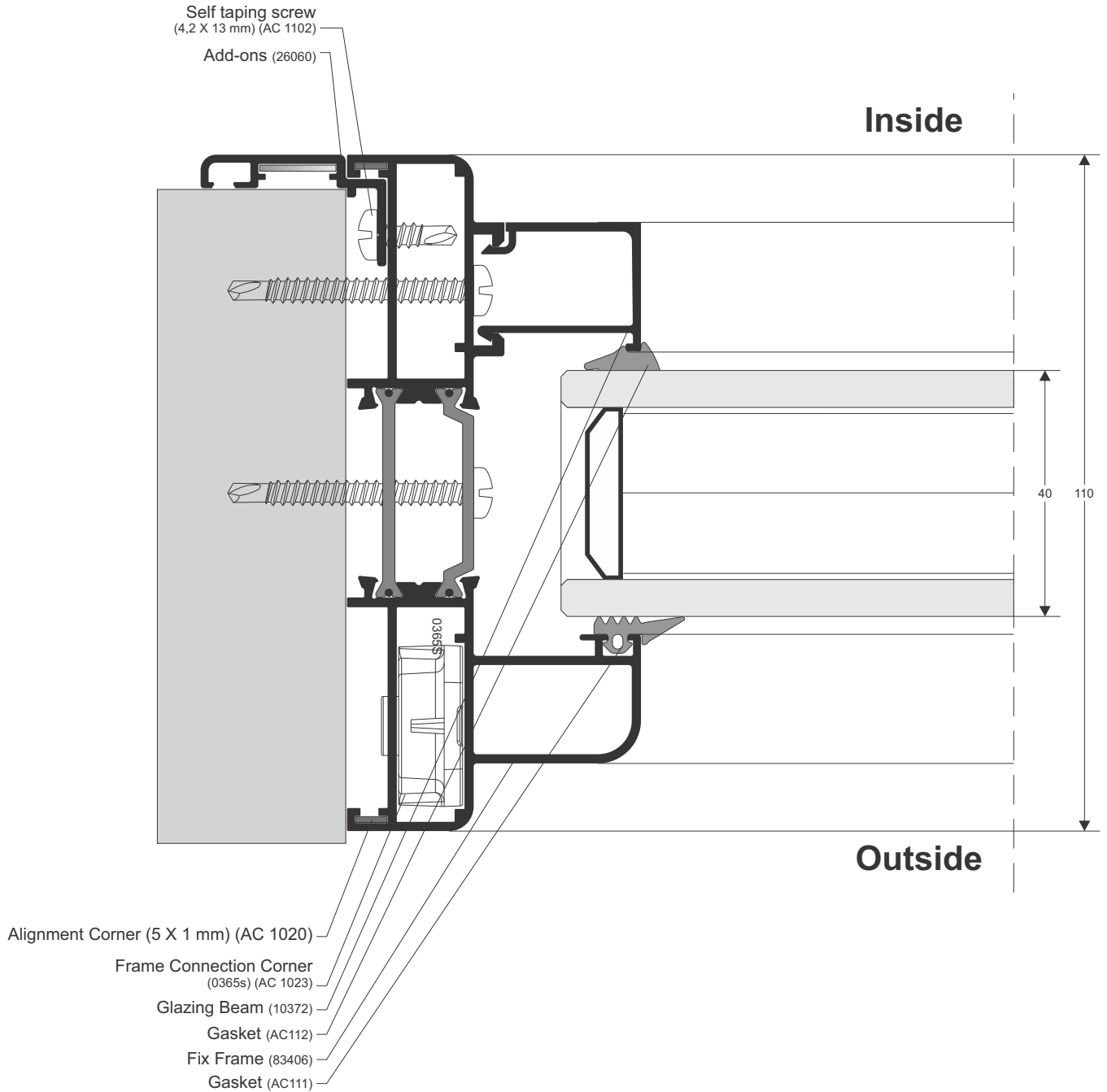

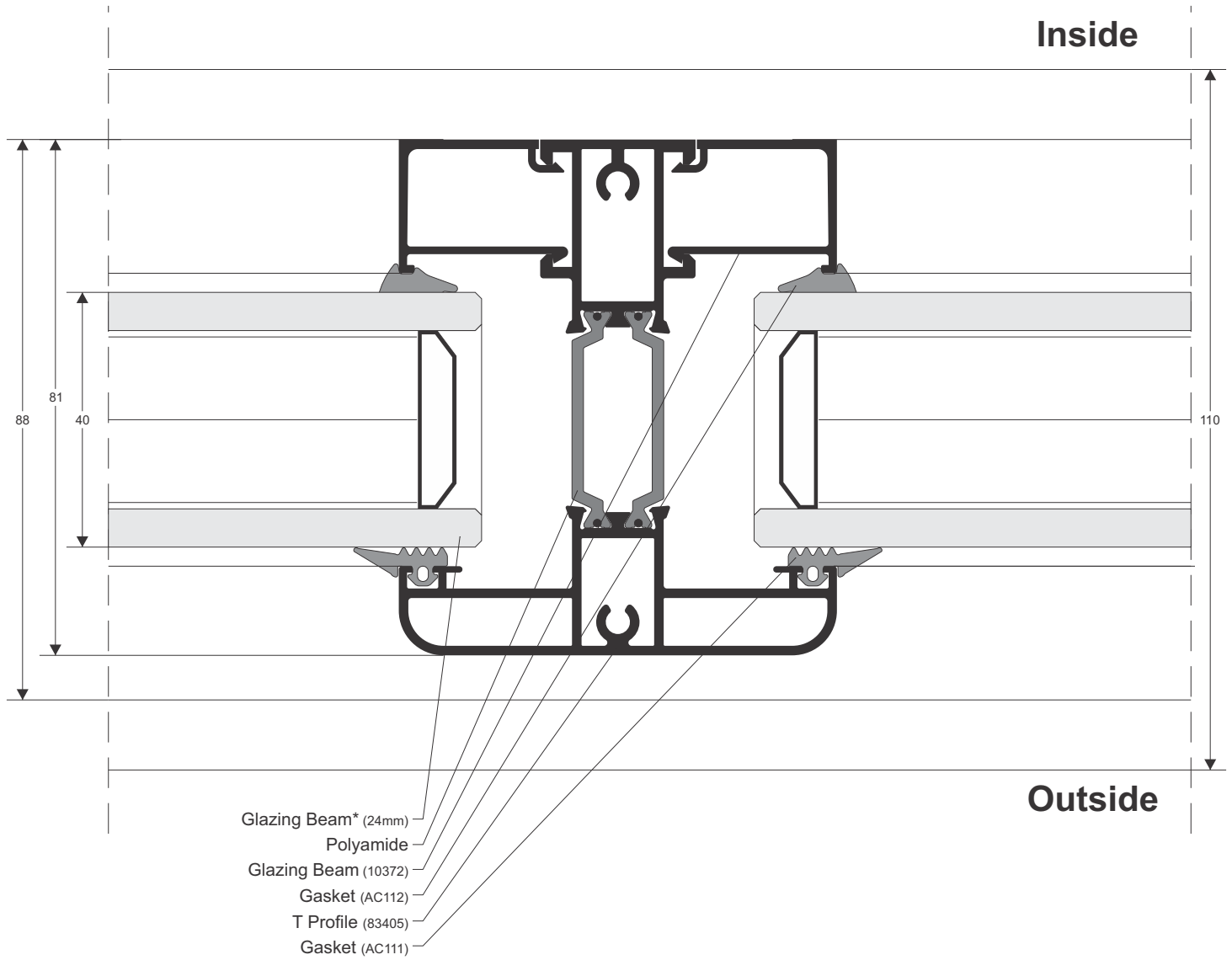

New Sliding System
Detail - C5

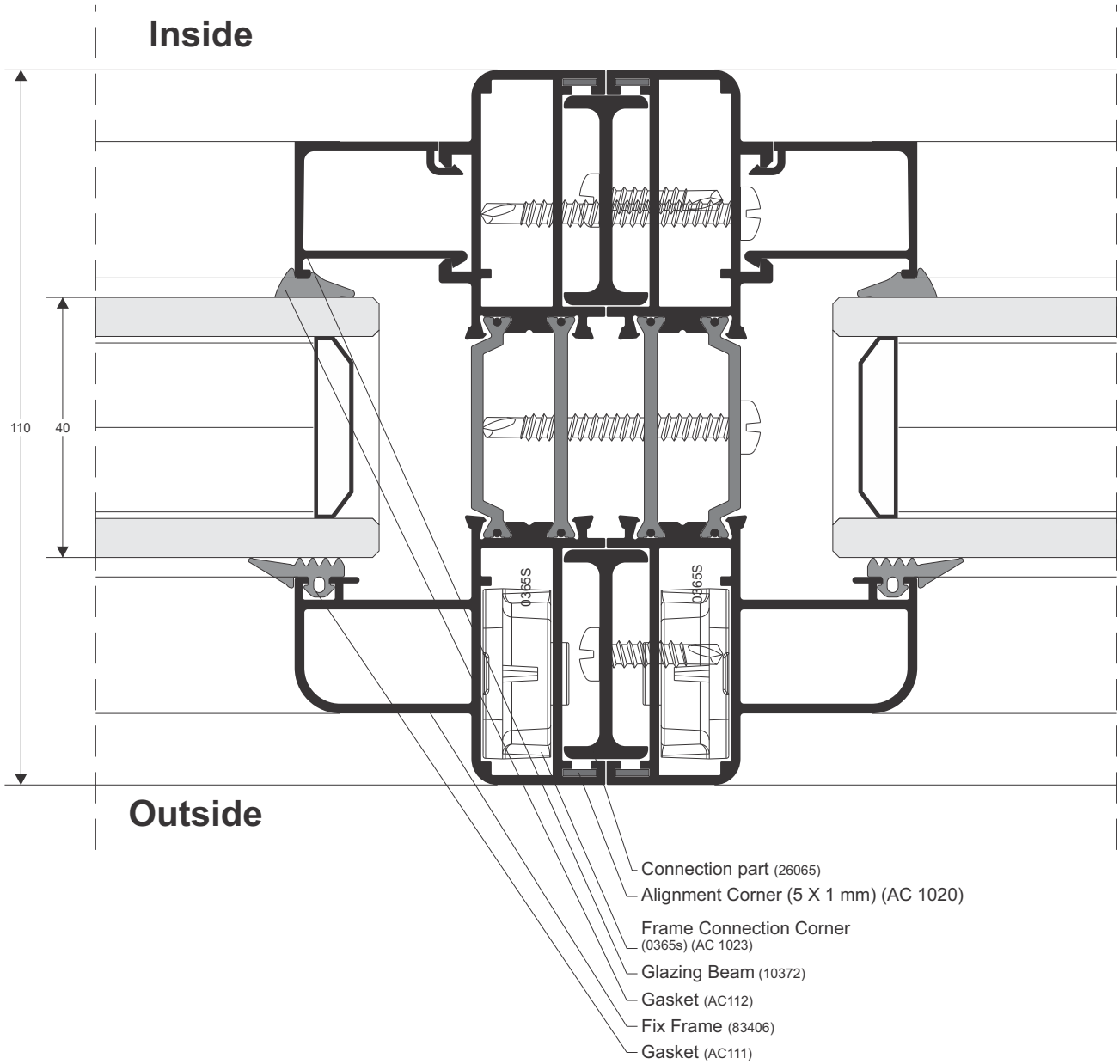

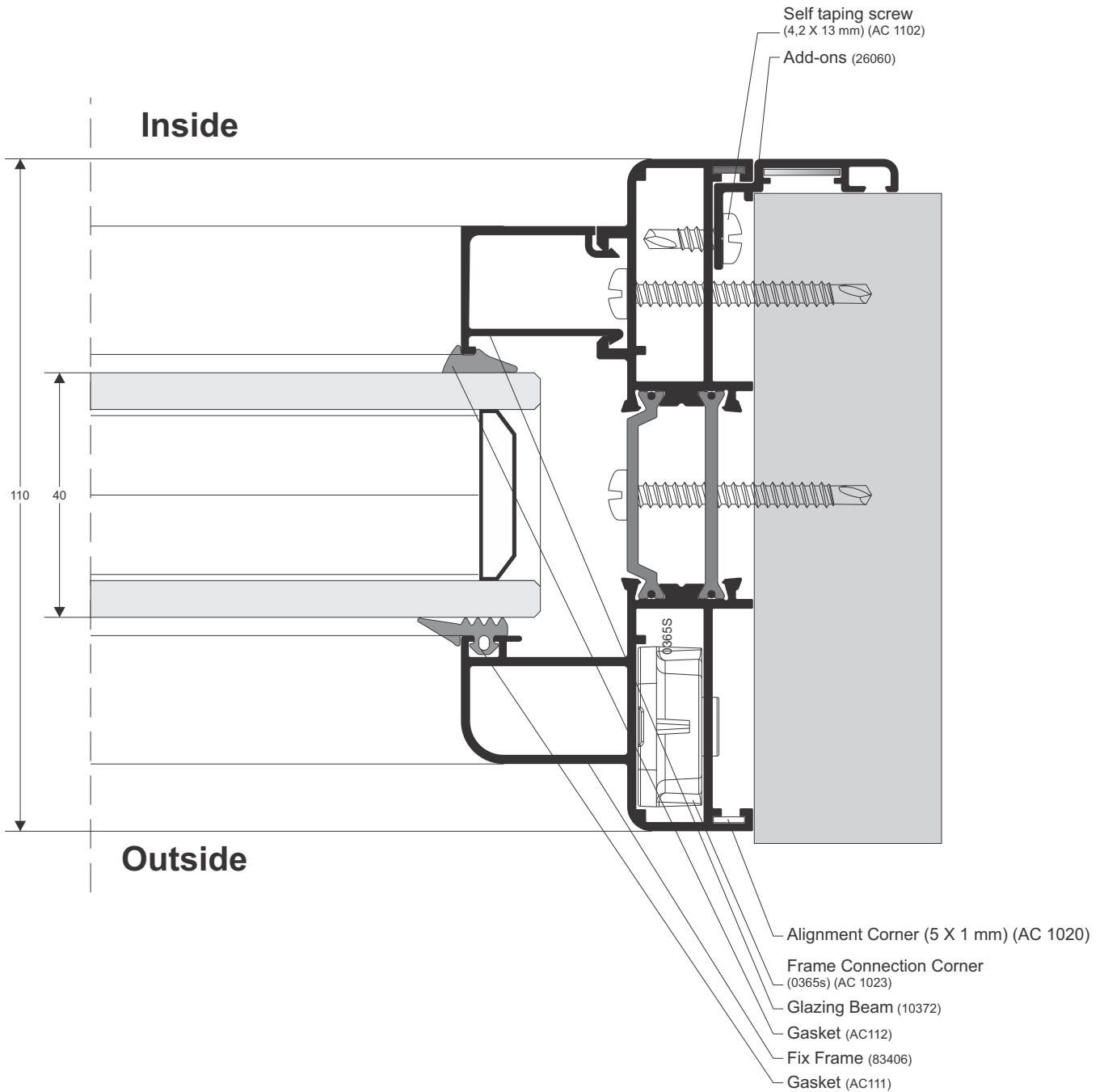

New Sliding System
Detail - A4

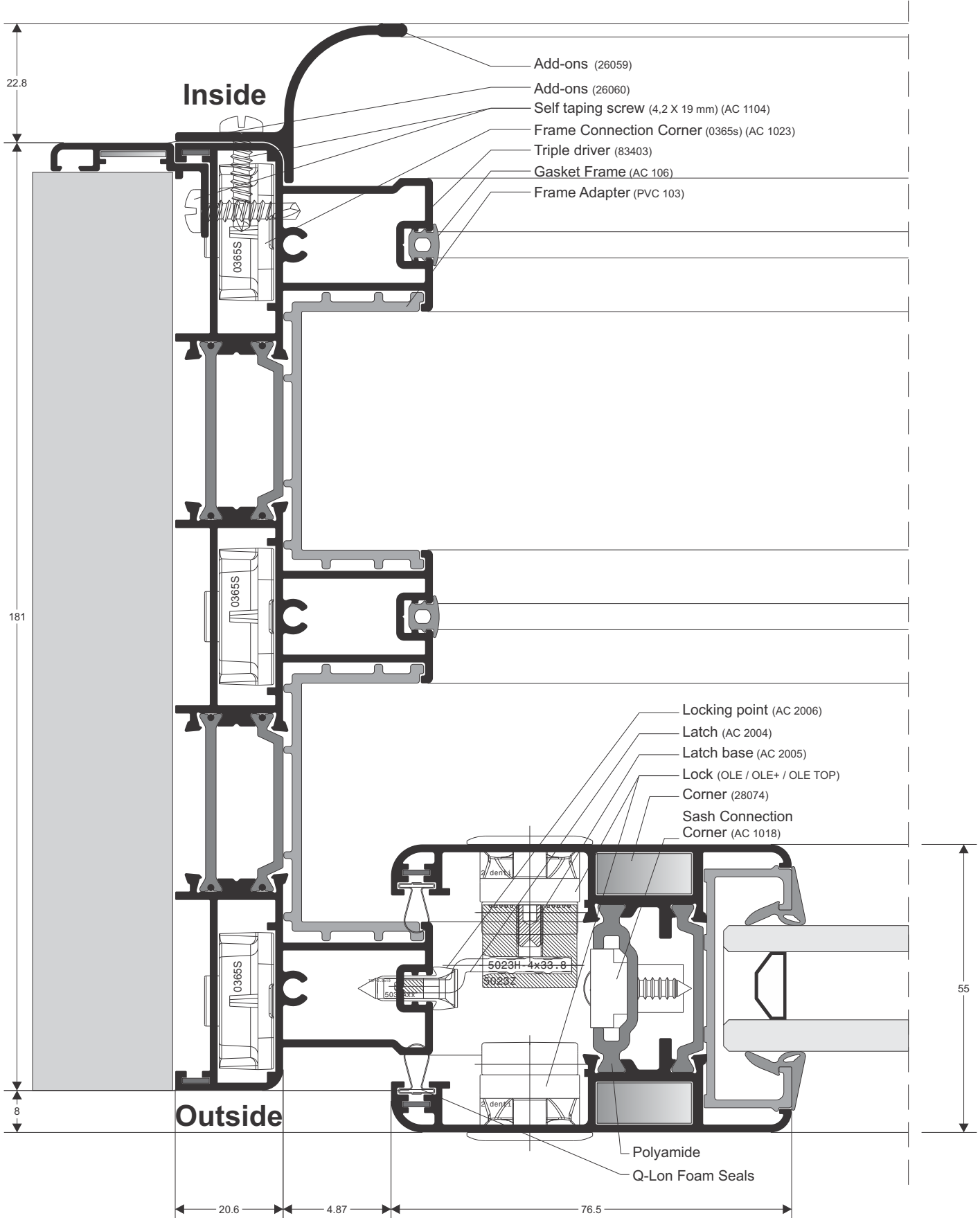

New Sliding System
Detail - A5

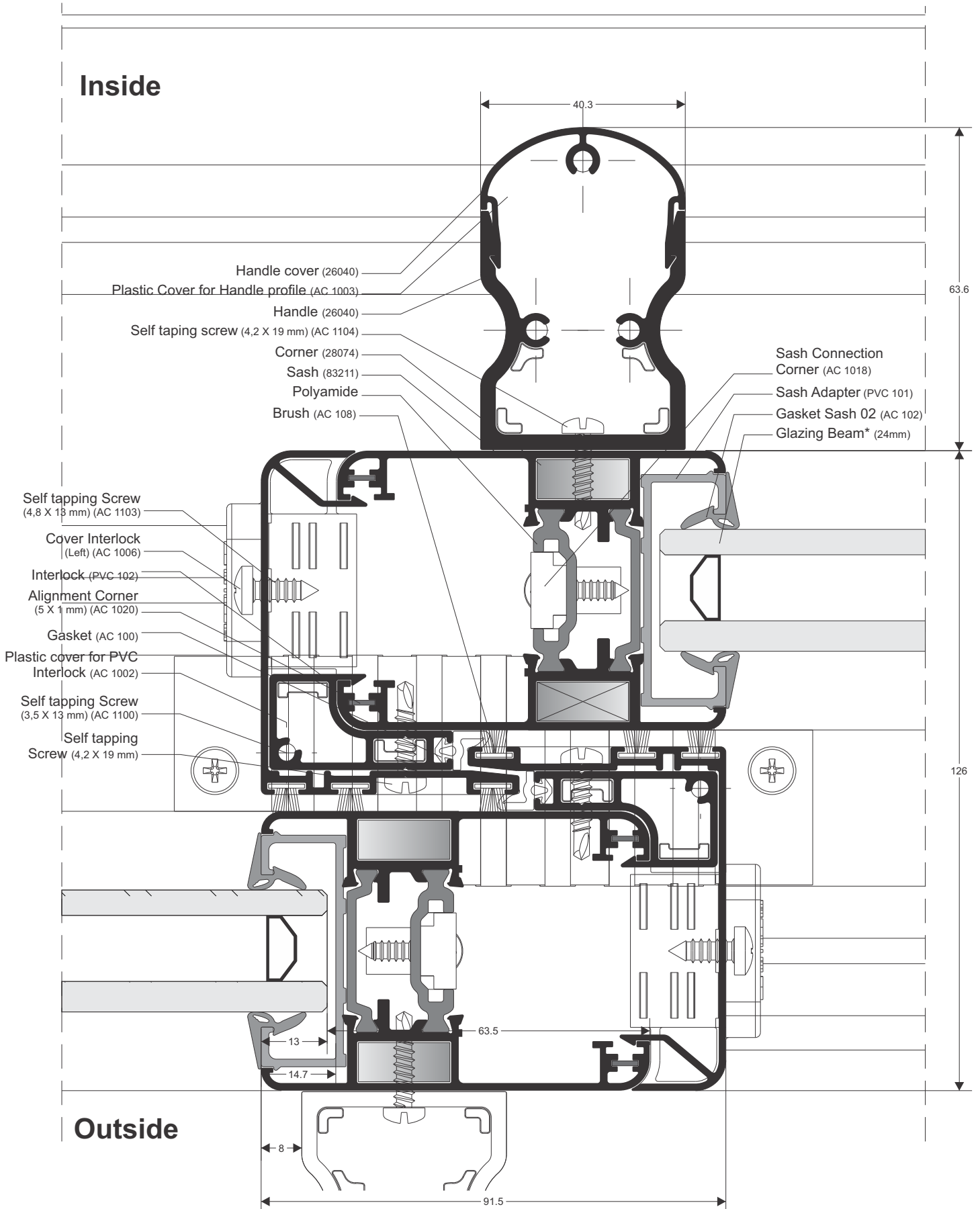

New Sliding System

Detail - A6

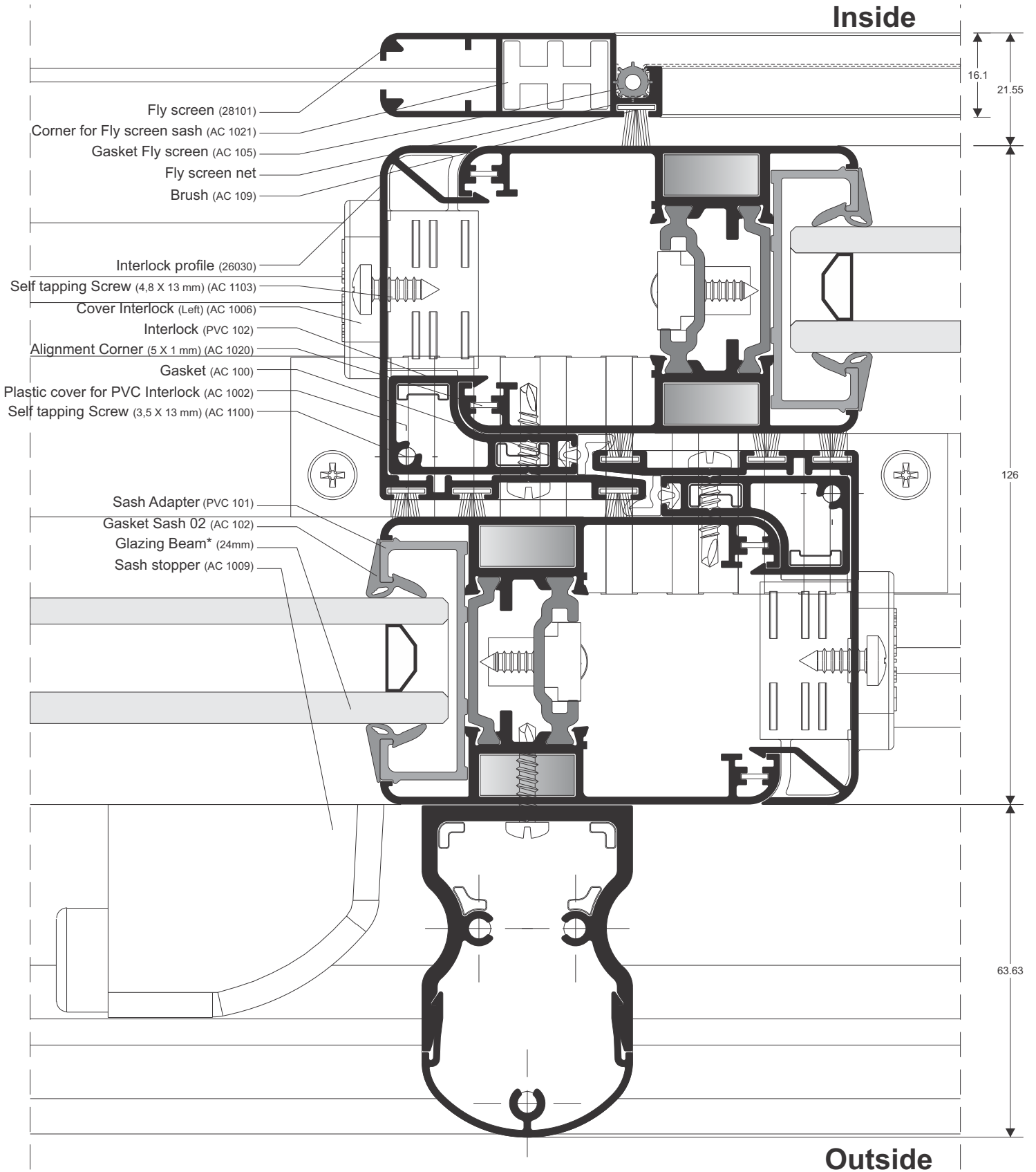

New Sliding System
Detail - A7

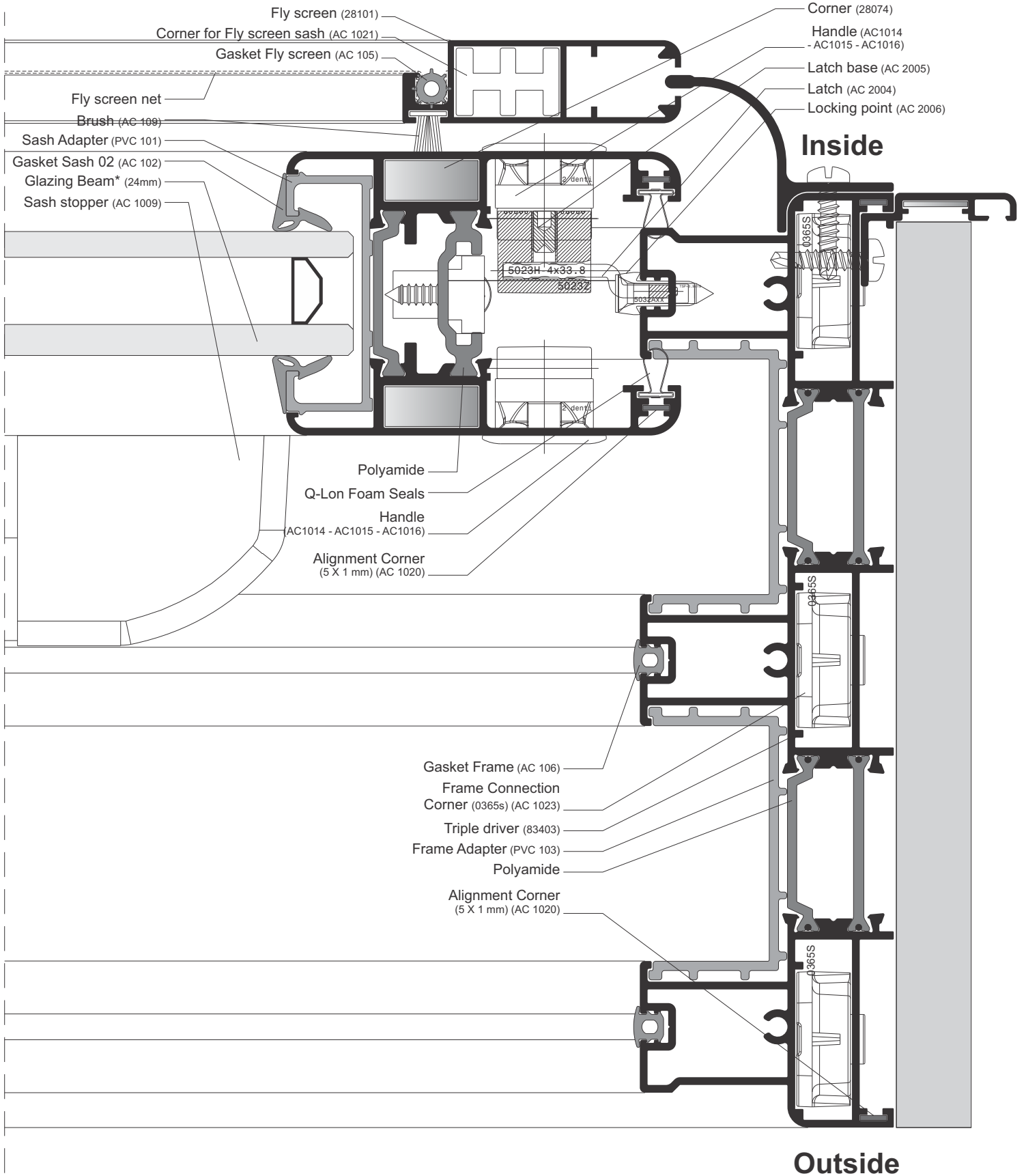

New Sliding System
Detail - B2

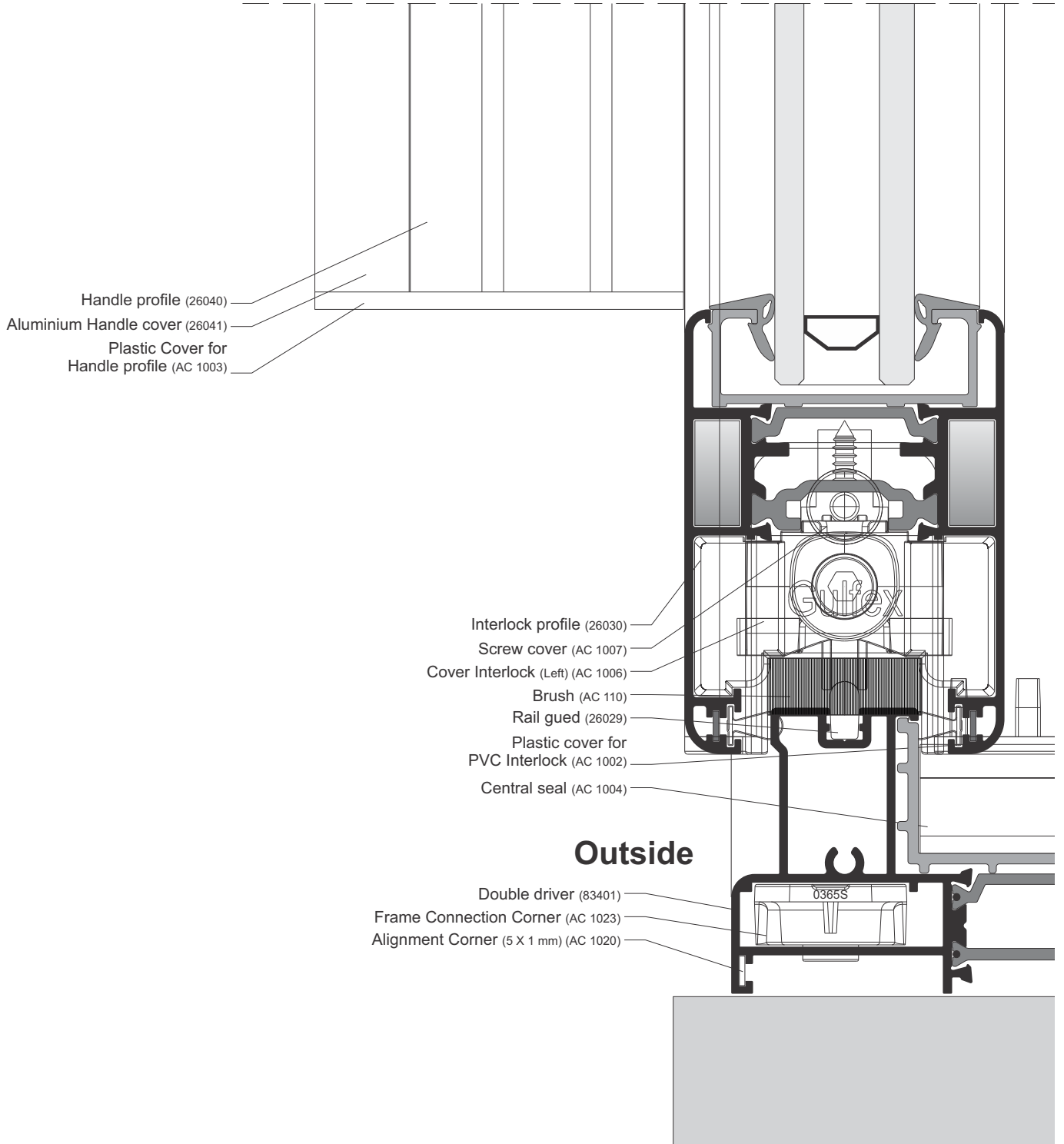



New Sliding System
Detail - B2

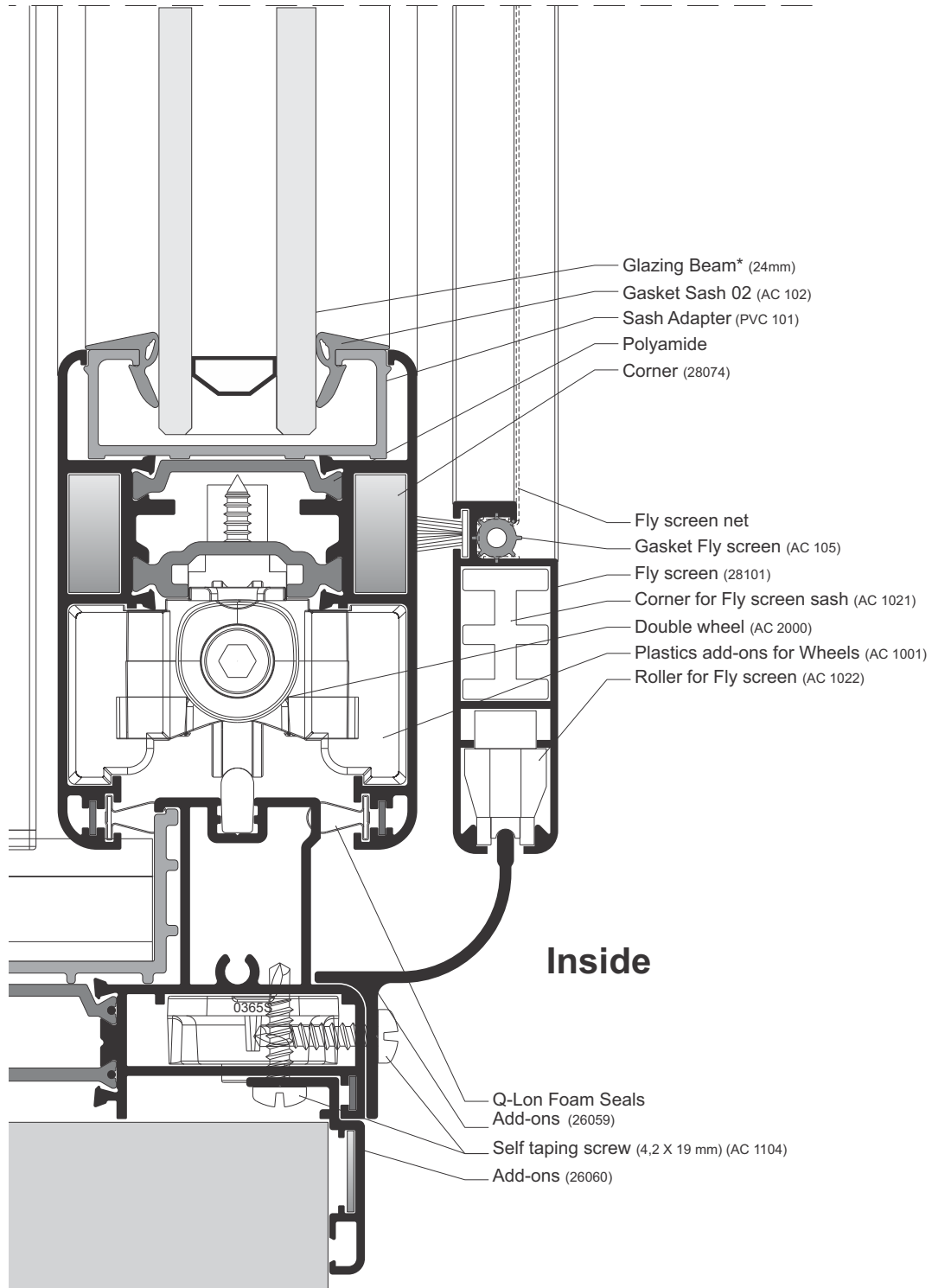

New Sliding System
Detail - B1

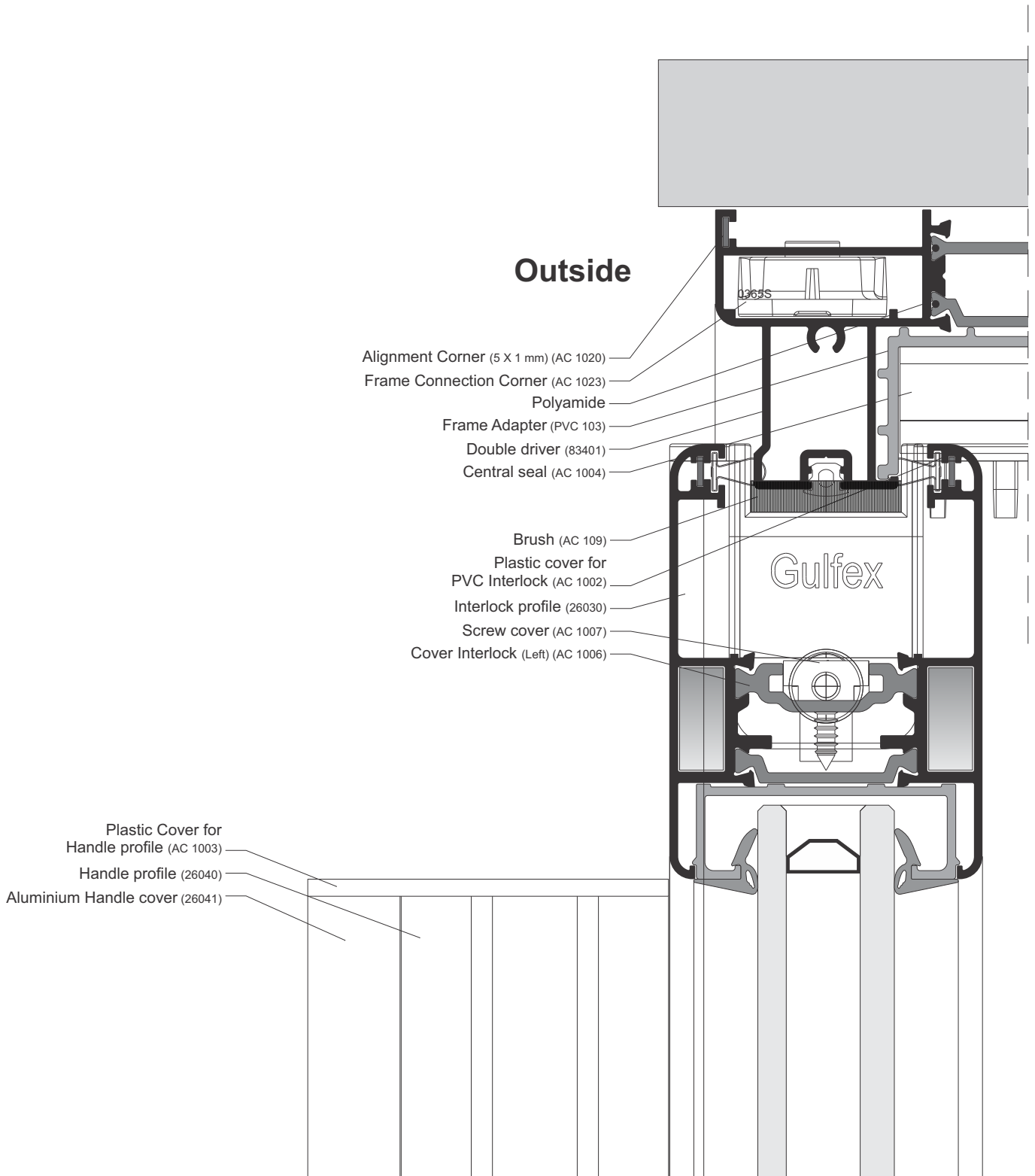



New Sliding System
Detail - B1

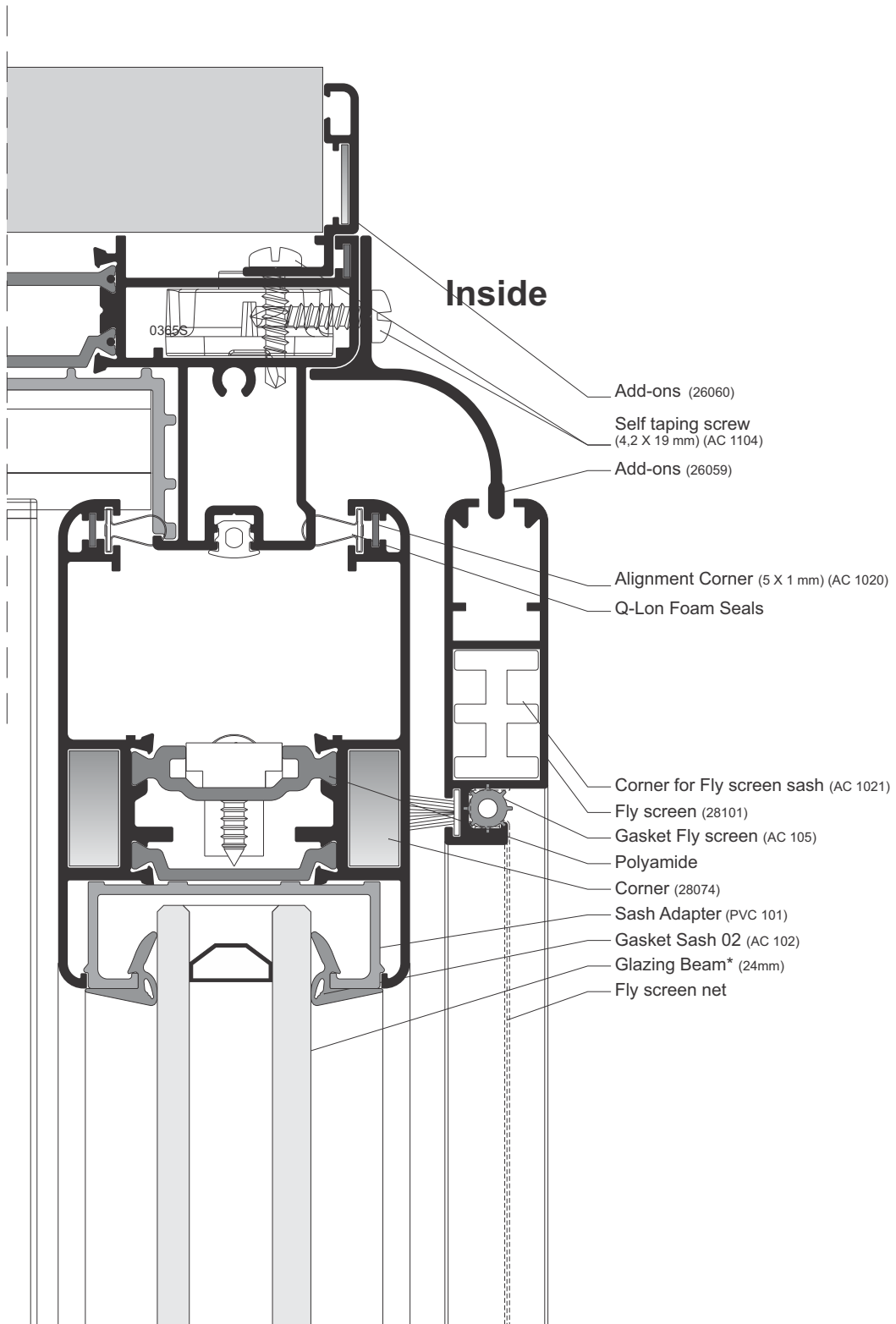

New Sliding System
Detail - B4

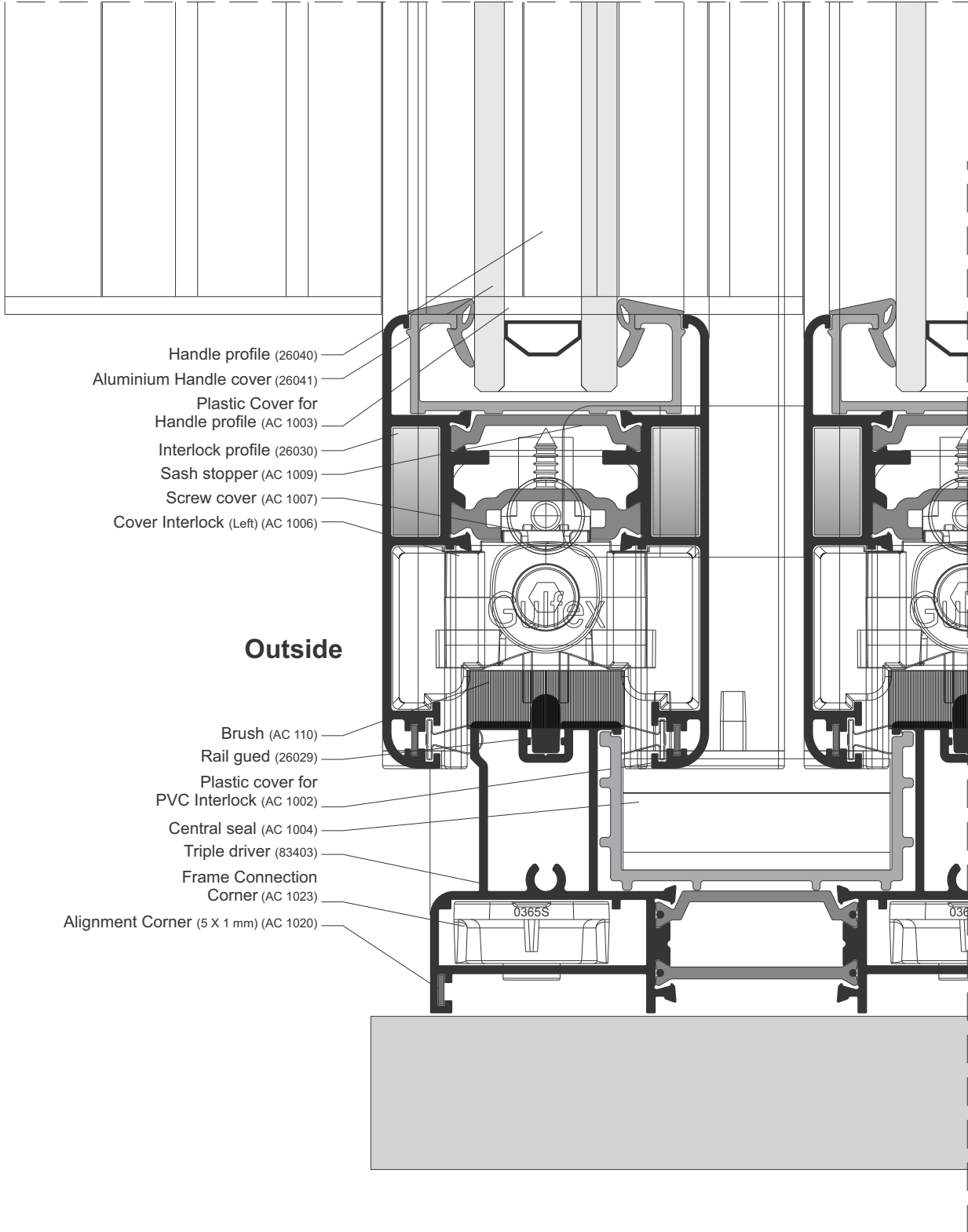

- Handle profile (26040)
- Aluminium Handle cover (26041)
- Plastic Cover for Handle profile (AC 1003)
- Interlock profile (26030)
- Sash stopper (AC 1009)
- Screw cover (AC 1007)
- Cover Interlock (Left) (AC 1006)

Outside

- Brush (AC 110)
- Rail gued (26029)
- Plastic cover for PVC Interlock (AC 1002)
- Central seal (AC 1004)
- Triple driver (83403)
- Frame Connection Corner (AC 1023)
- Alignment Corner (5 X 1 mm) (AC 1020)

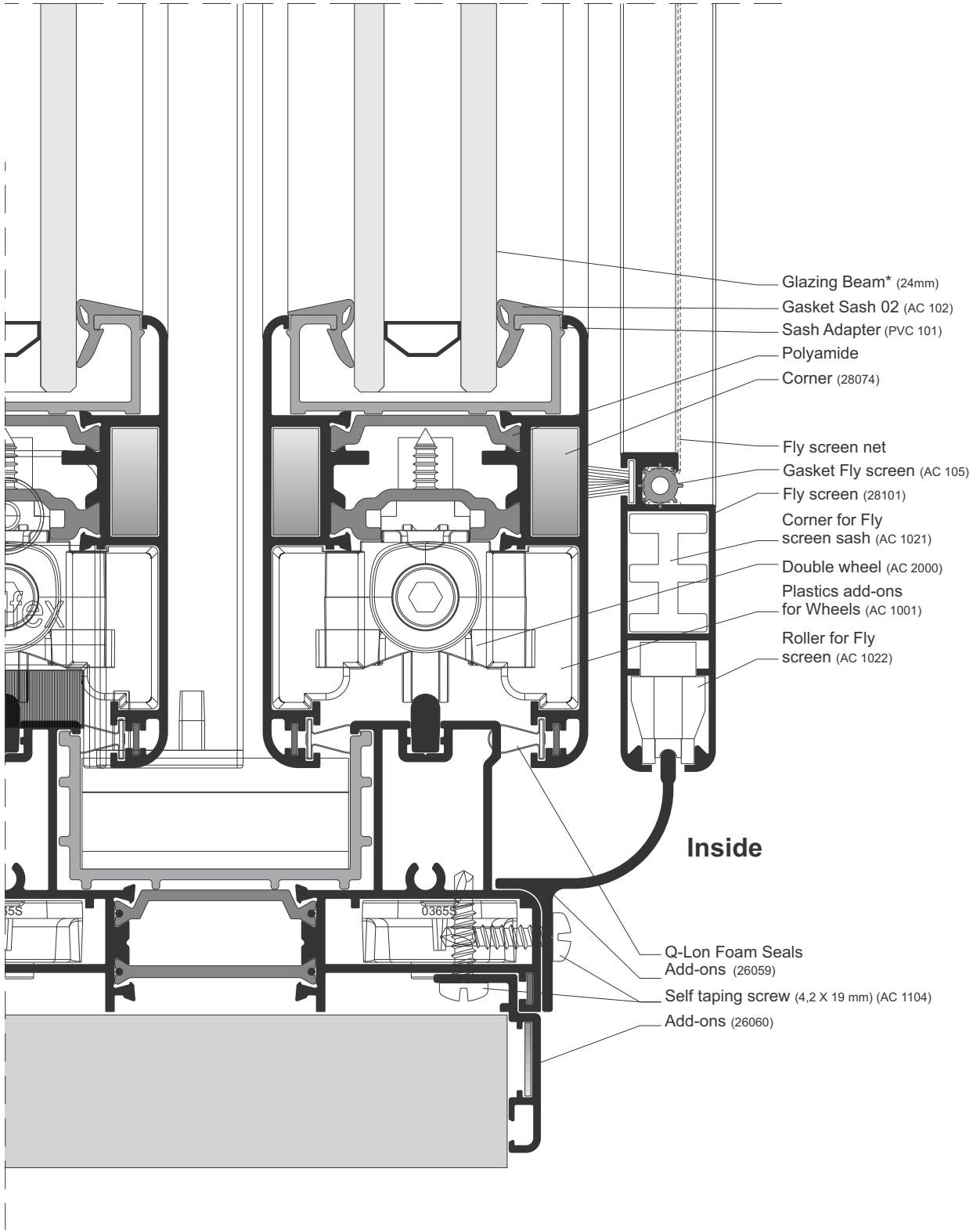

New Sliding System
Detail - B3

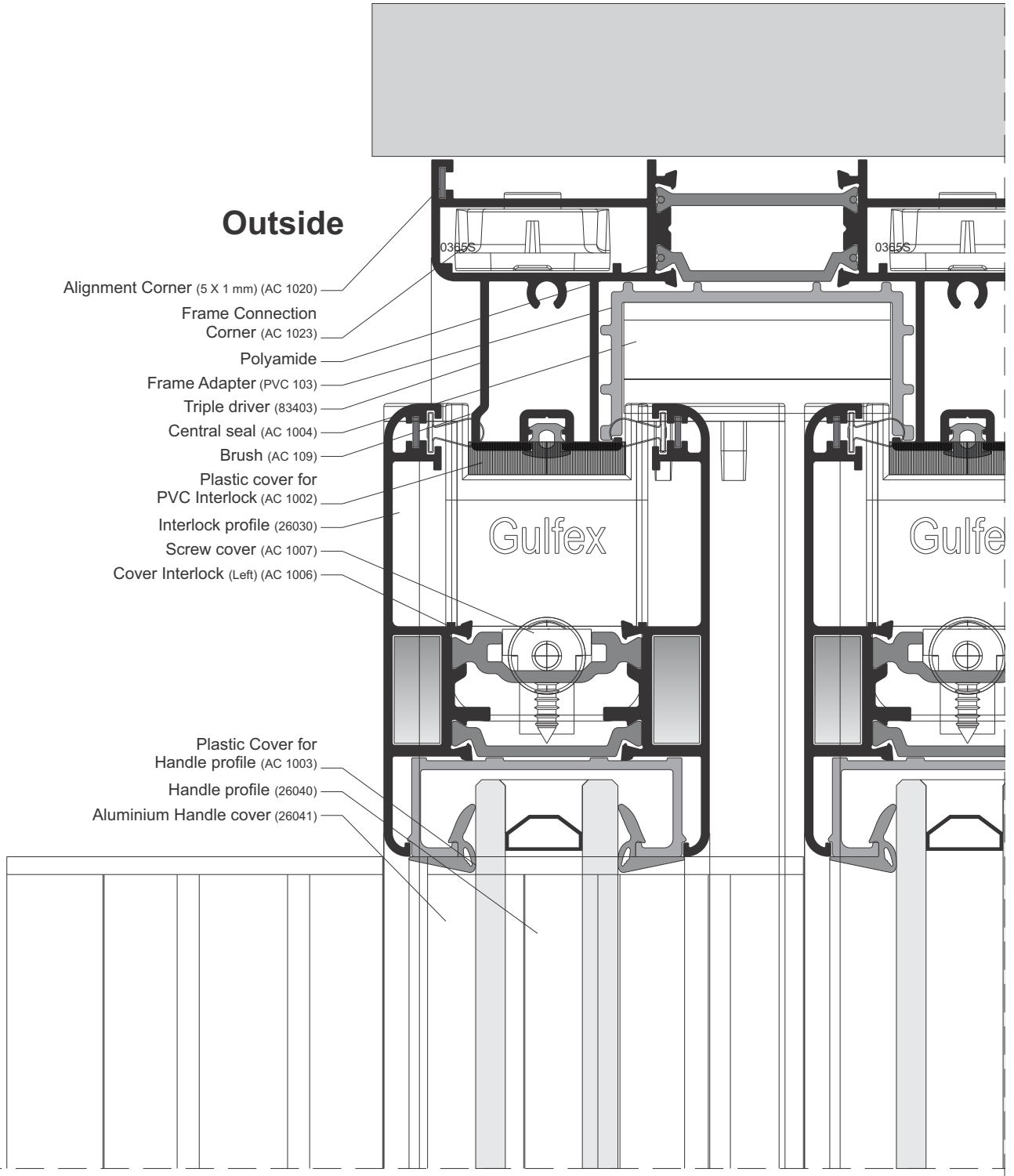

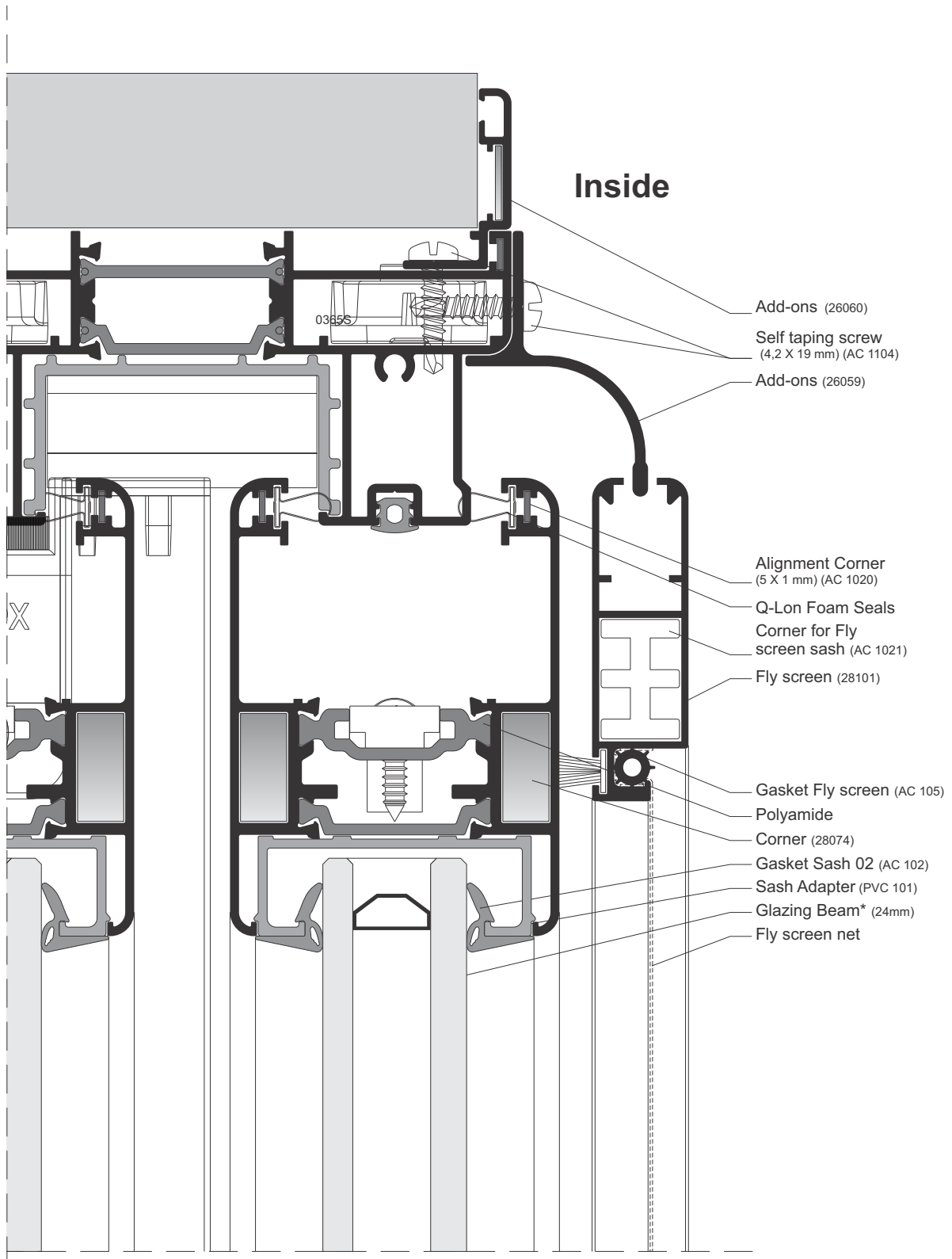

New Sliding System
Detail - B5

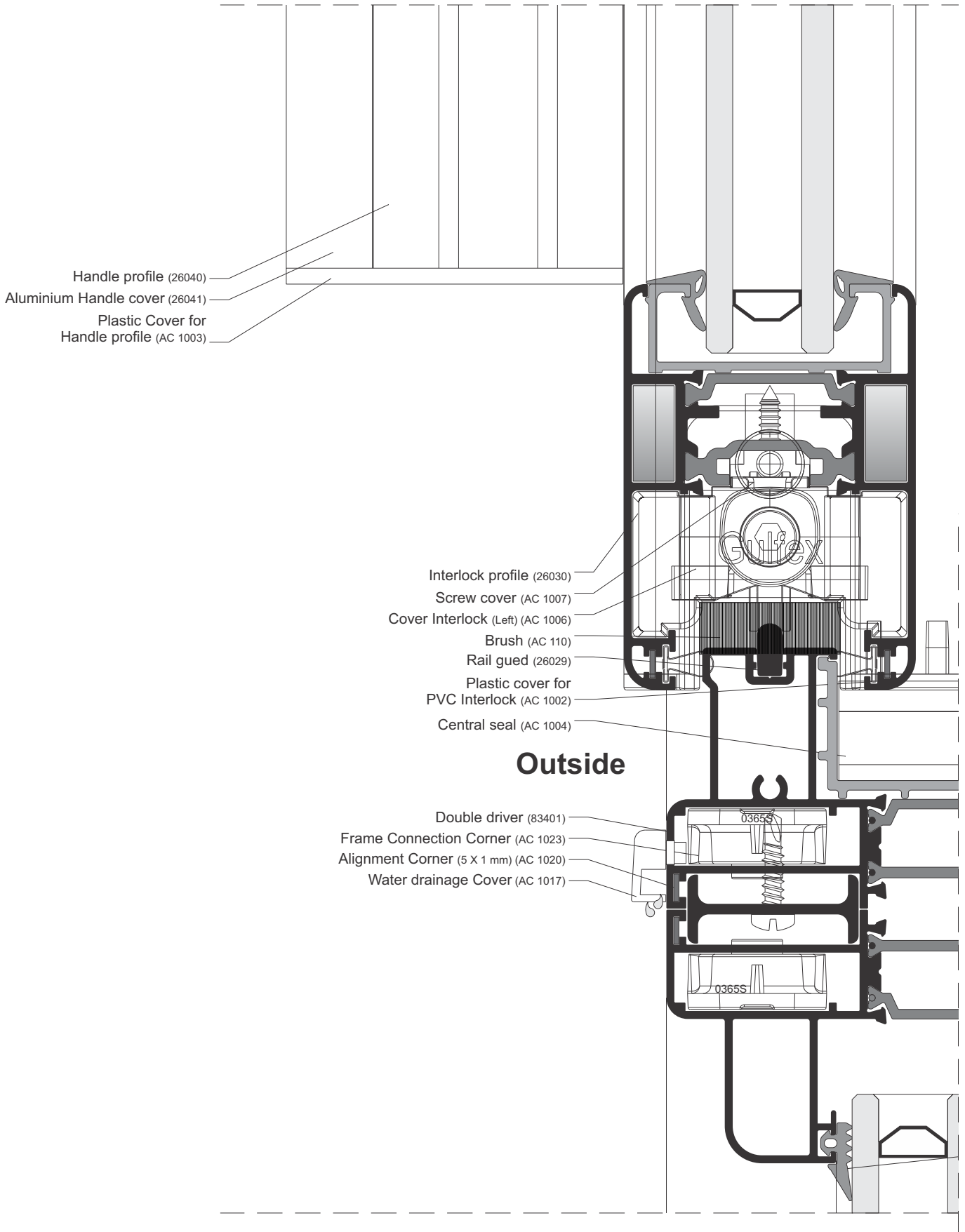

Handle profile (26040)
Aluminium Handle cover (26041)
Plastic Cover for
Handle profile (AC 1003)

Interlock profile (26030)
Screw cover (AC 1007)
Cover Interlock (Left) (AC 1006)
Brush (AC 110)
Rail guide (26029)
Plastic cover for
PVC Interlock (AC 1002)
Central seal (AC 1004)

Outside

Double driver (83401)
Frame Connection Corner (AC 1023)
Alignment Corner (5 X 1 mm) (AC 1020)
Water drainage Cover (AC 1017)

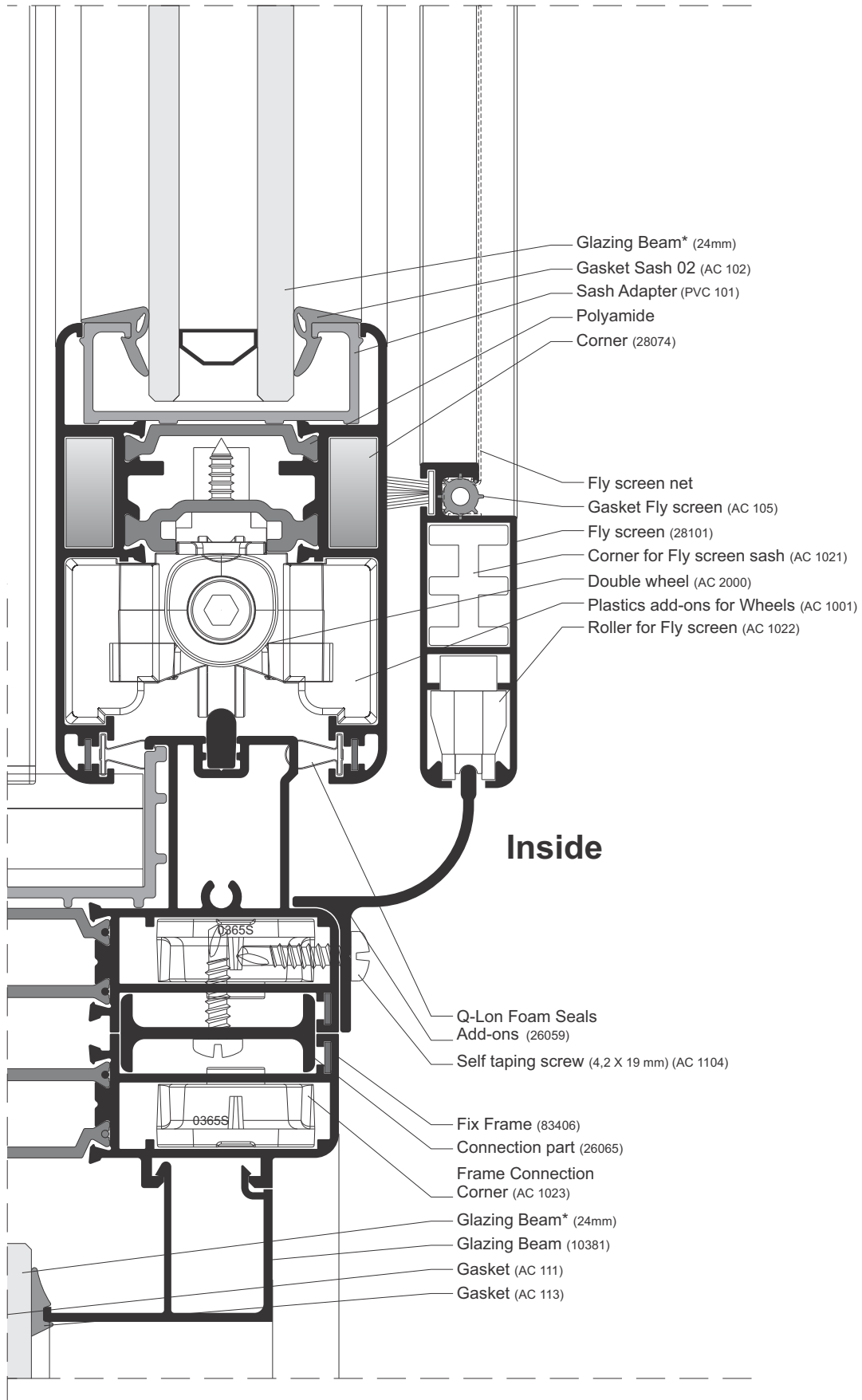

New Sliding System
Detail - B5

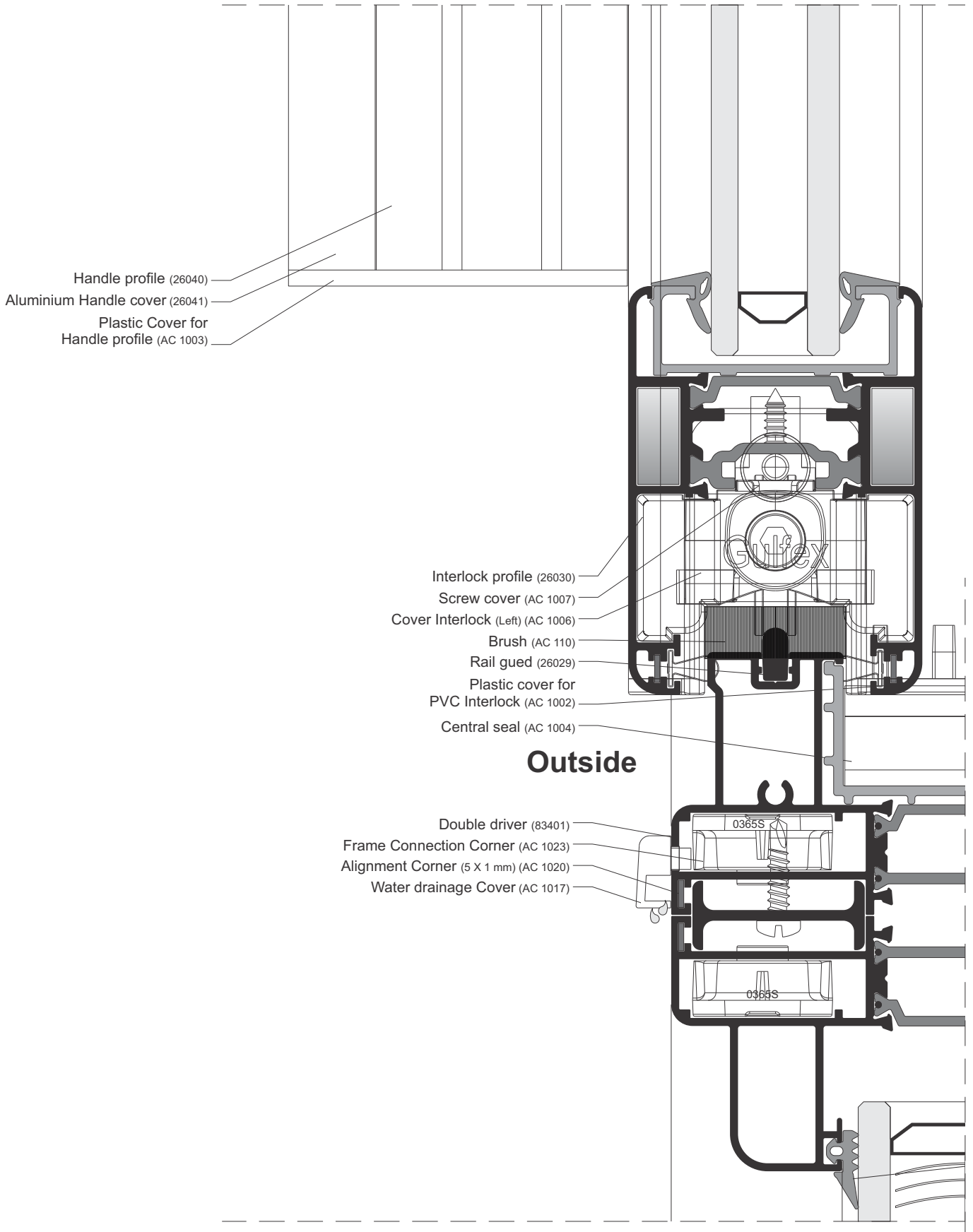

New Sliding System
Detail - B5

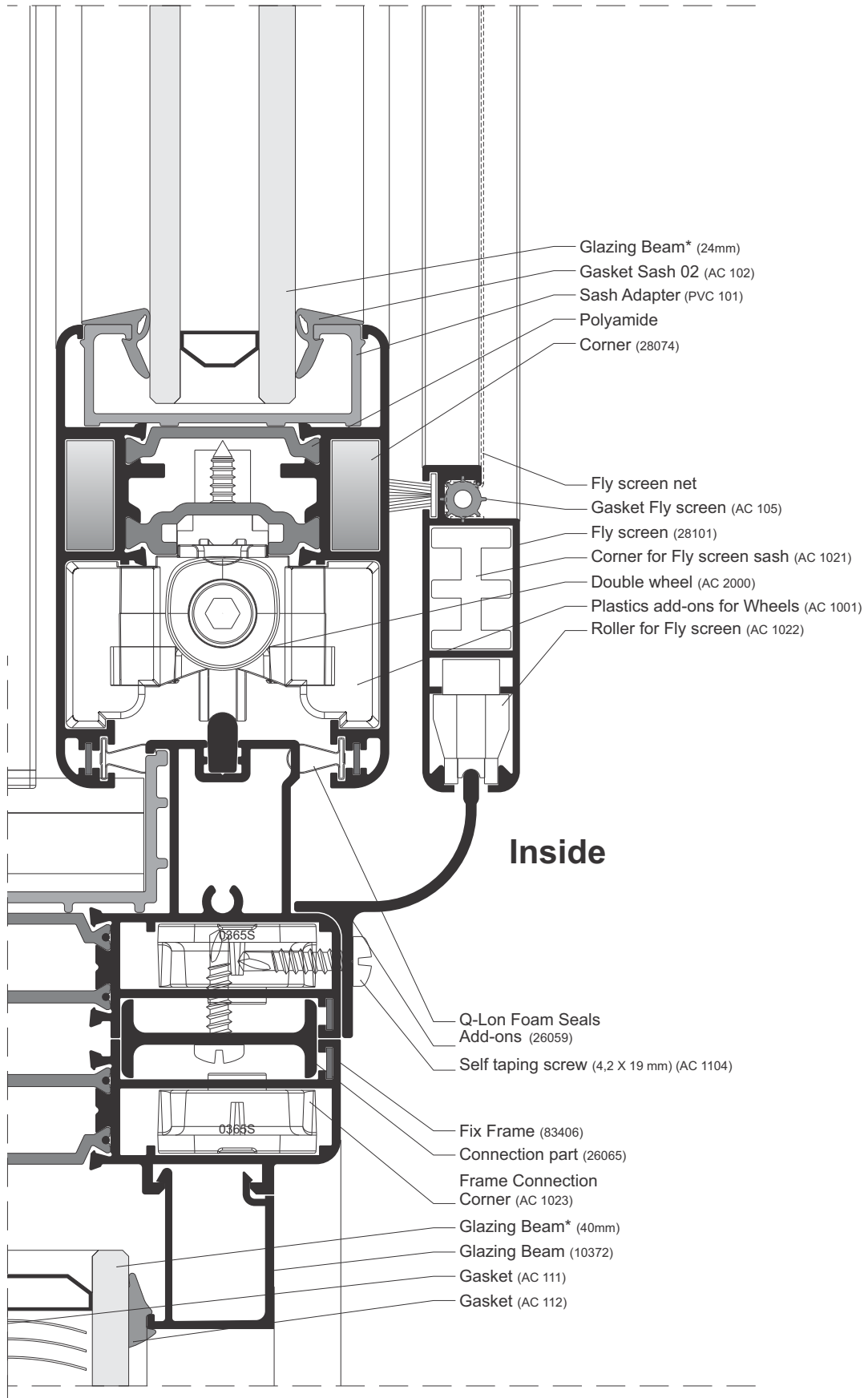

New Sliding System
Detail - B7

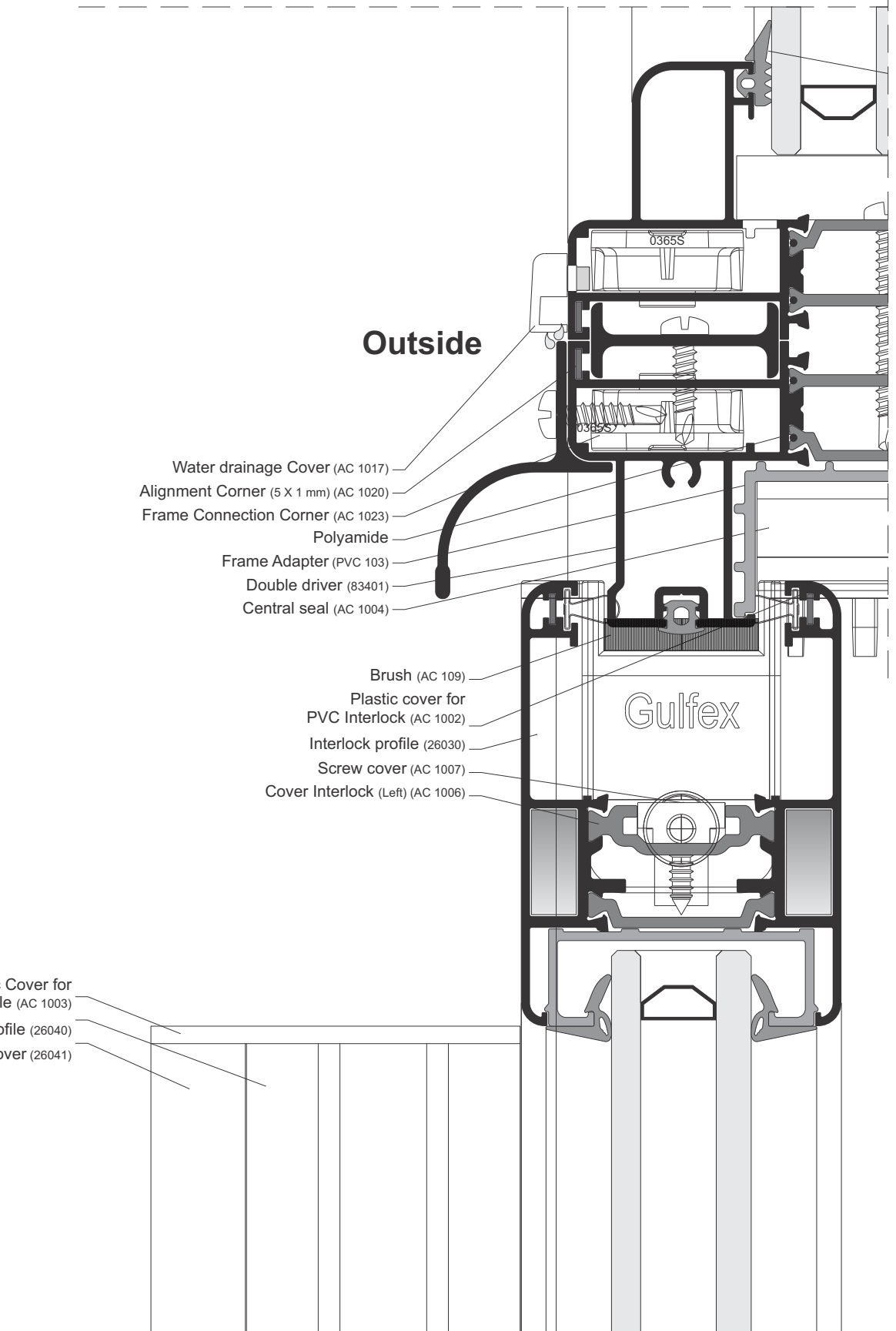

Outside

- Water drainage Cover (AC 1017)
- Alignment Corner (5 X 1 mm) (AC 1020)
- Frame Connection Corner (AC 1023)
- Polyamide
- Frame Adapter (PVC 103)
- Double driver (83401)
- Central seal (AC 1004)

- Brush (AC 109)
- Plastic cover for PVC Interlock (AC 1002)
- Interlock profile (26030)
- Screw cover (AC 1007)
- Cover Interlock (Left) (AC 1006)

Gulfex

- Plastic Cover for Handle profile (AC 1003)
- Handle profile (26040)
- Aluminium Handle cover (26041)

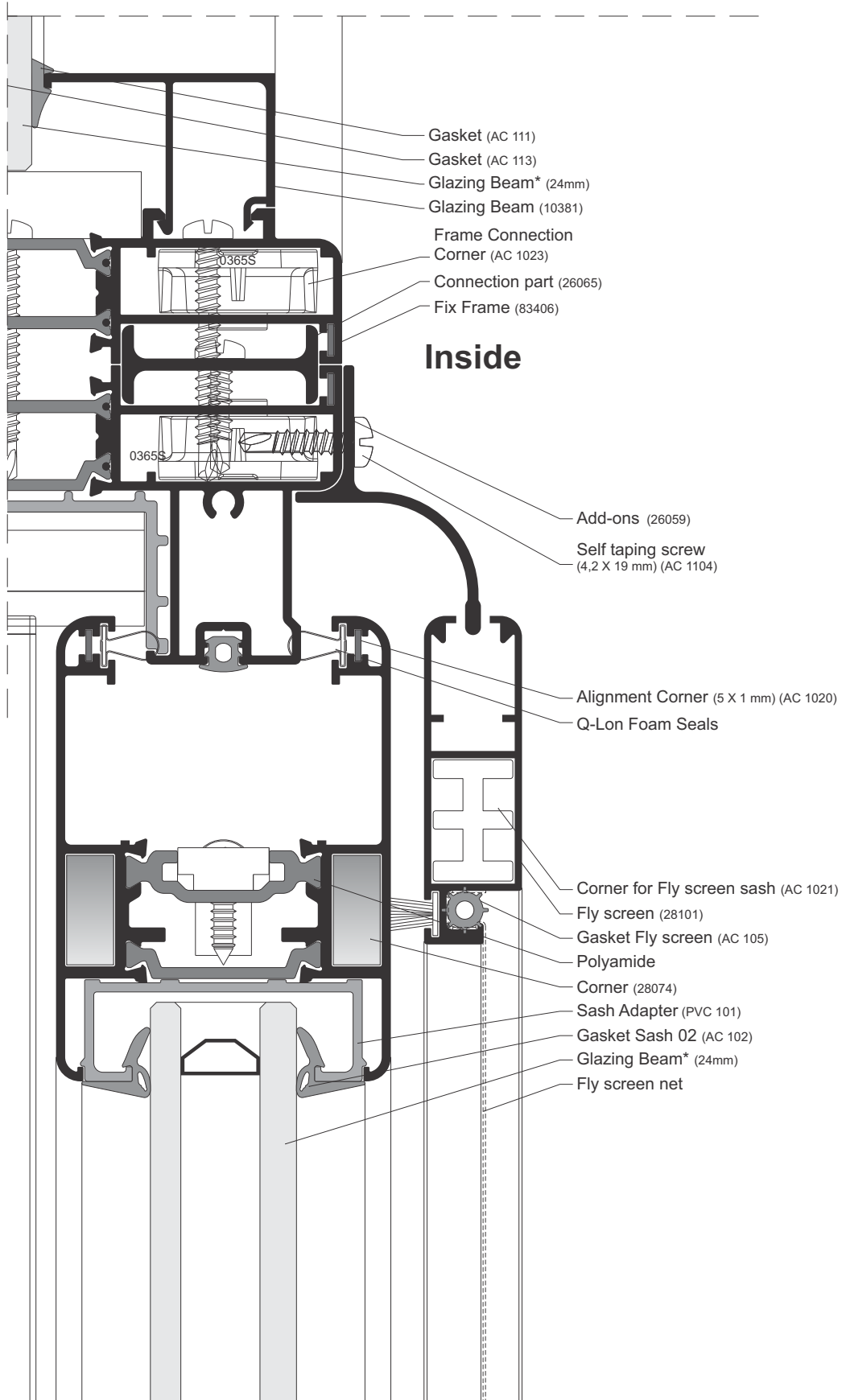

New Sliding System
Detail - B7

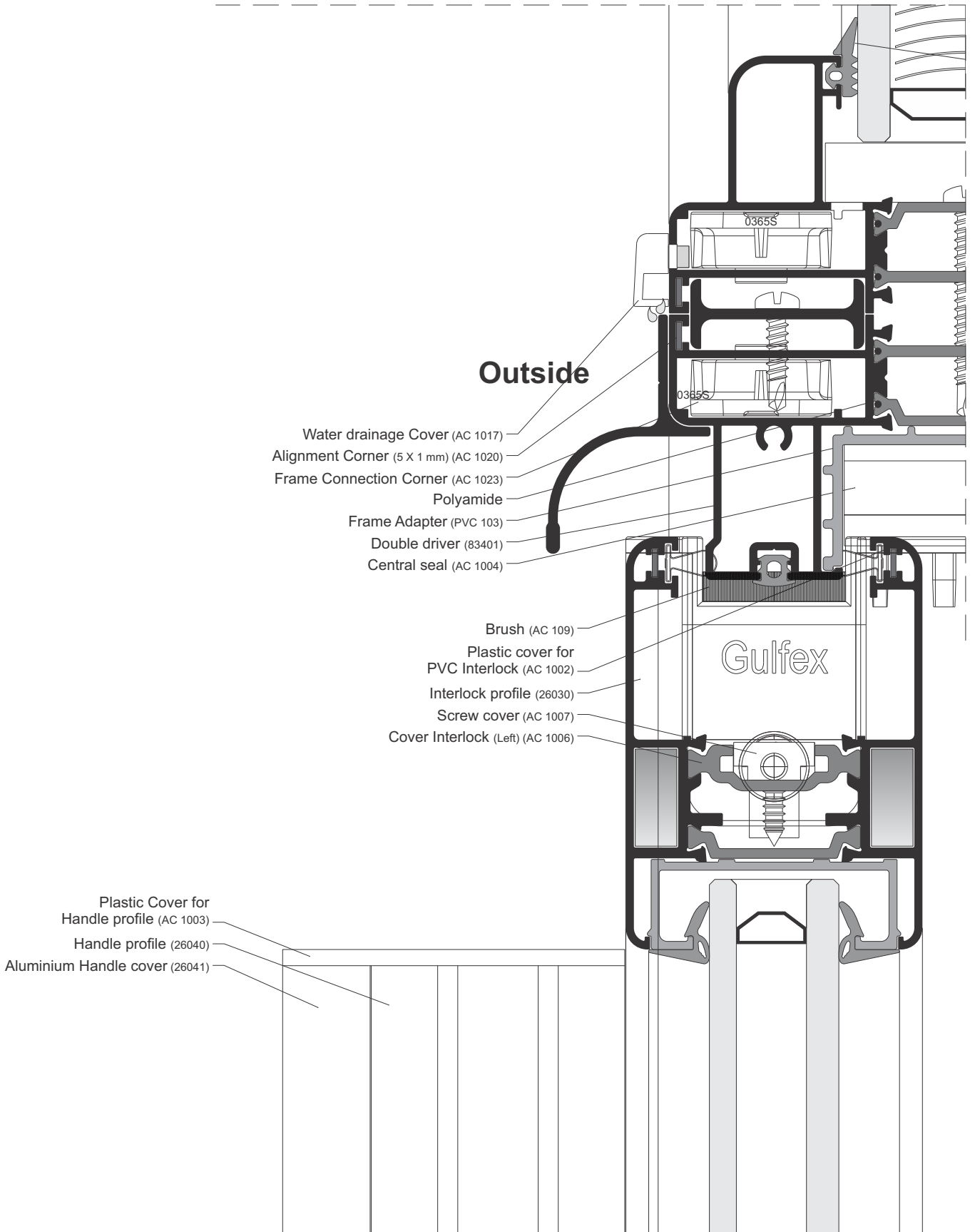

Outside

- Water drainage Cover (AC 1017)
- Alignment Corner (5 X 1 mm) (AC 1020)
- Frame Connection Corner (AC 1023)
- Polyamide
- Frame Adapter (PVC 103)
- Double driver (83401)
- Central seal (AC 1004)

- Brush (AC 109)
- Plastic cover for PVC Interlock (AC 1002)
- Interlock profile (26030)
- Screw cover (AC 1007)
- Cover Interlock (Left) (AC 1006)

Gulfex

- Plastic Cover for Handle profile (AC 1003)
- Handle profile (26040)
- Aluminium Handle cover (26041)

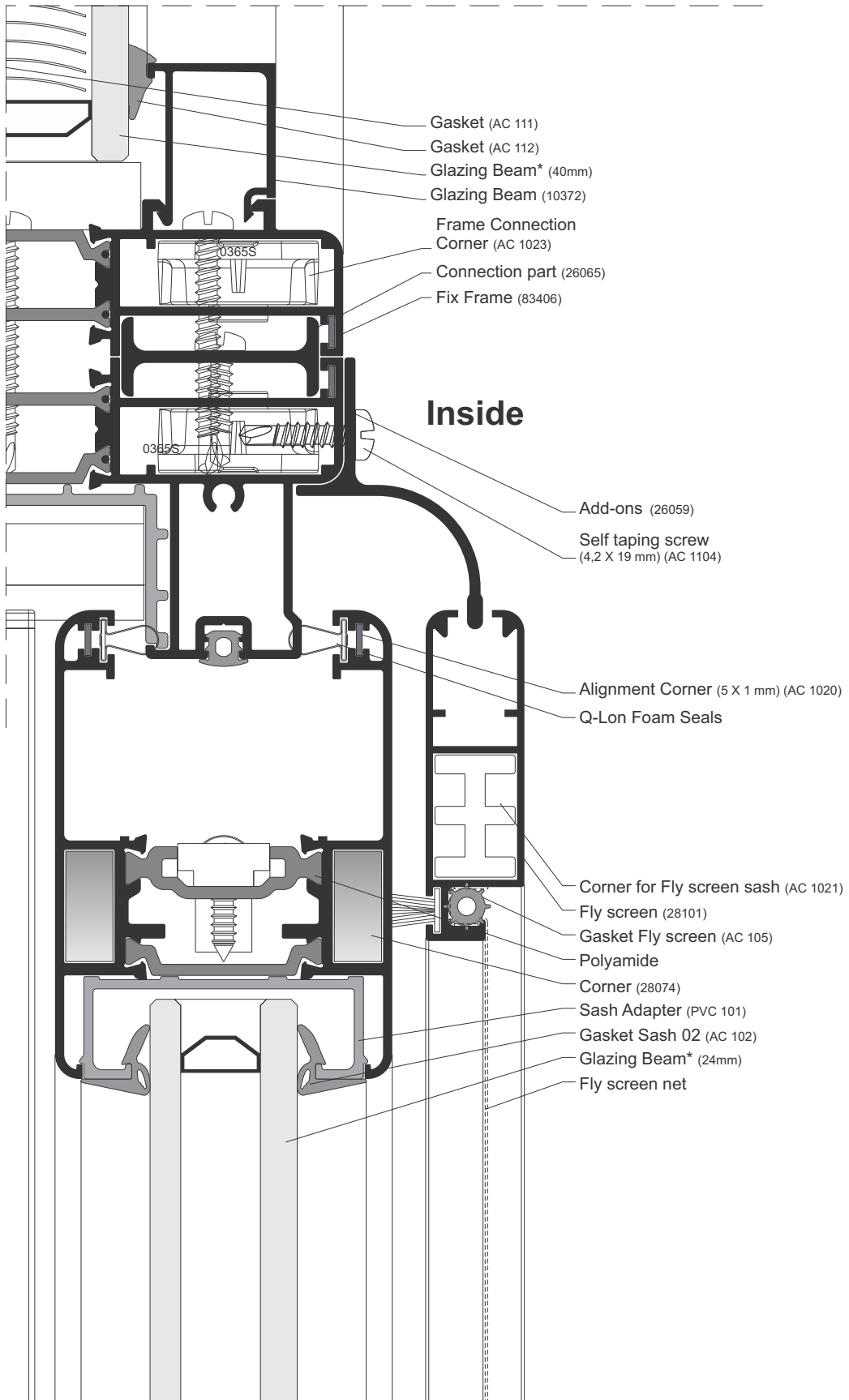

New Sliding System
Detail - B8

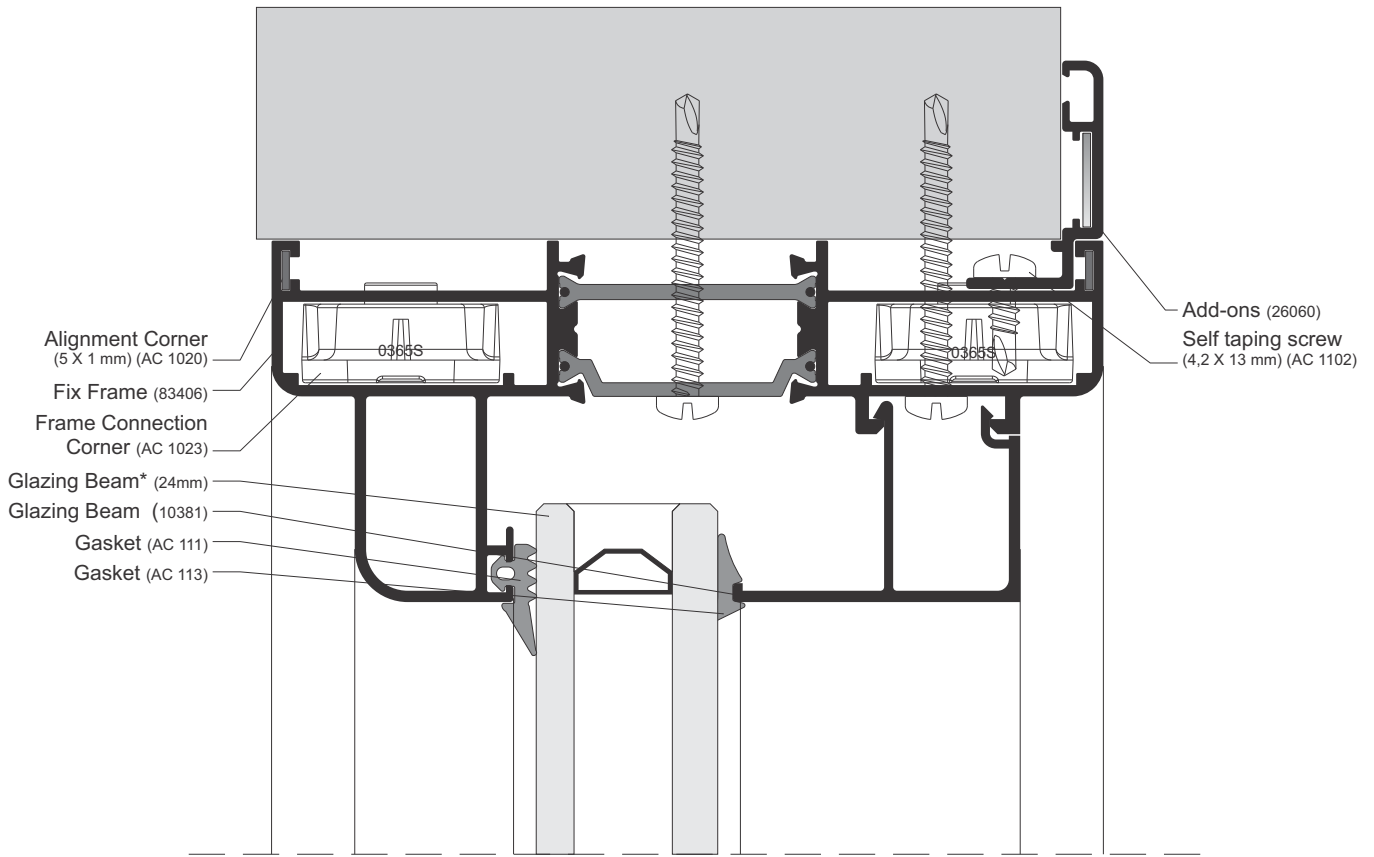

New Sliding System
Detail - B6

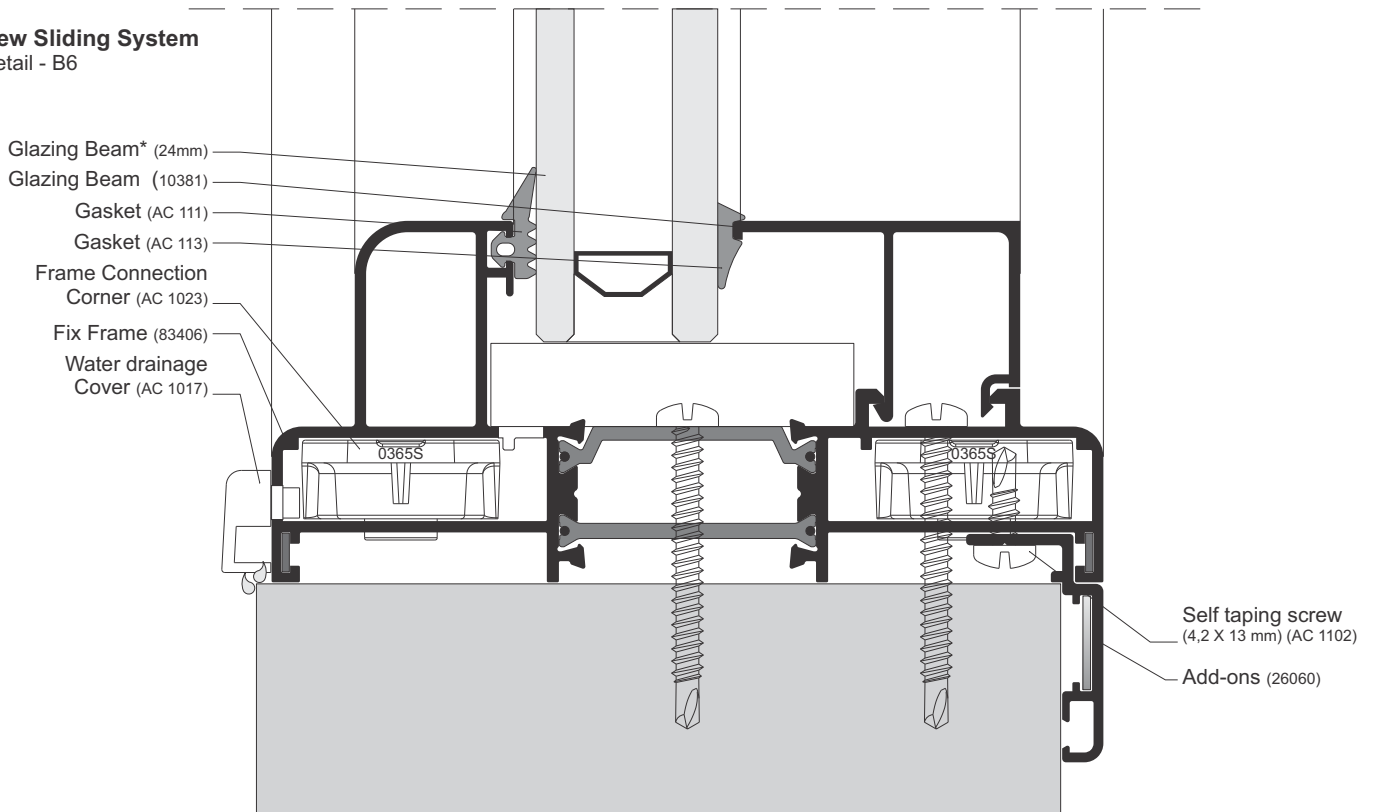

New Sliding System
Detail - B8

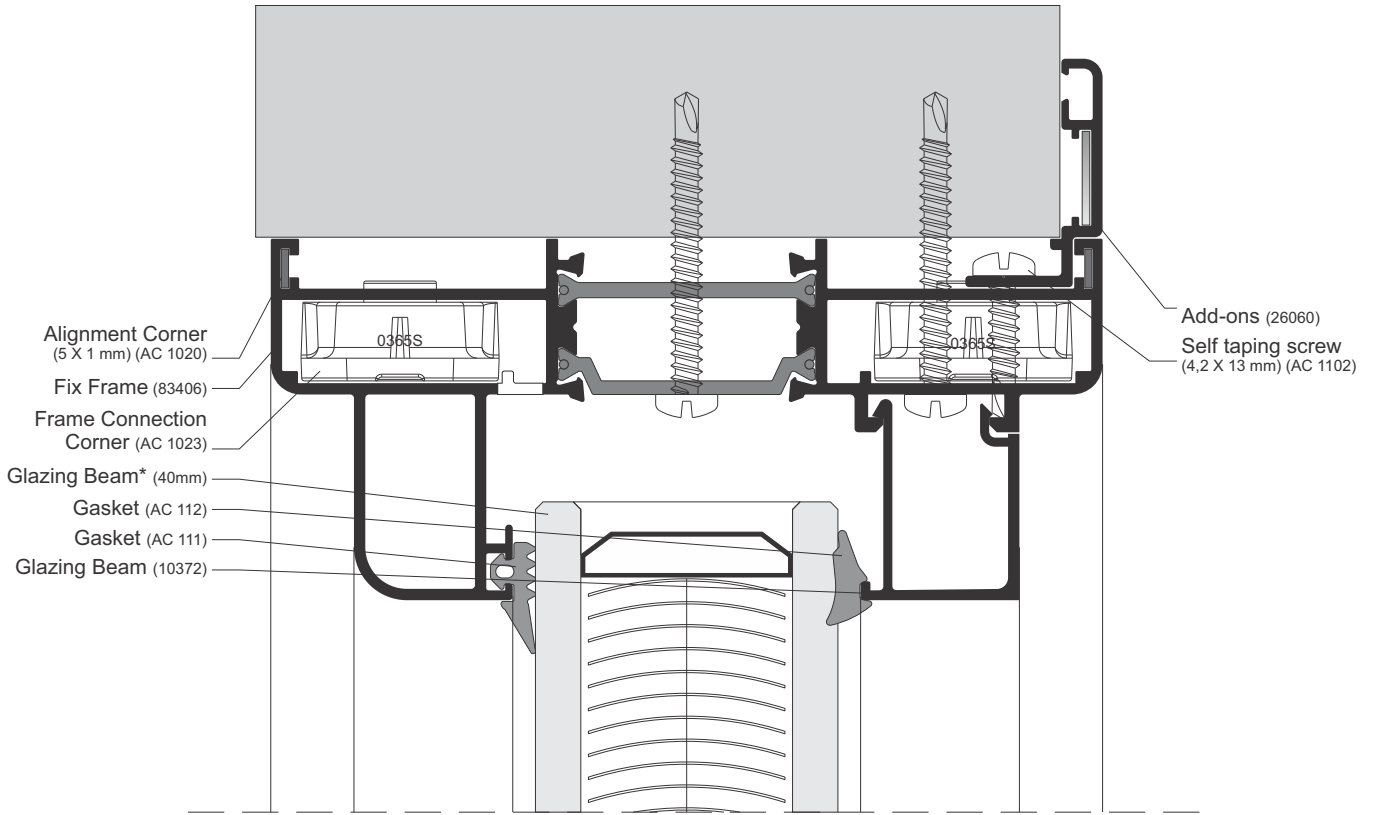

New Sliding System
Detail - B6

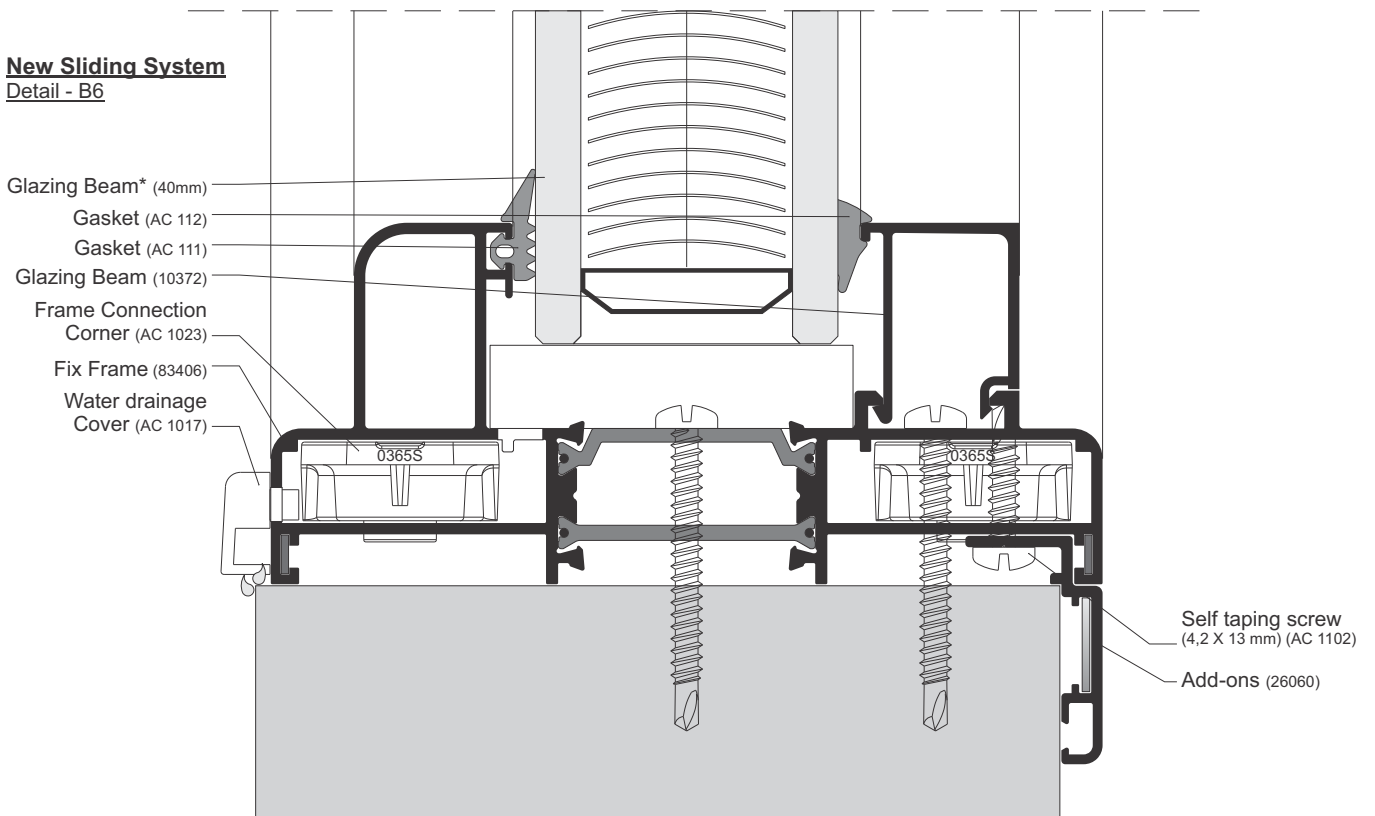

New Sliding System
Detail - B9

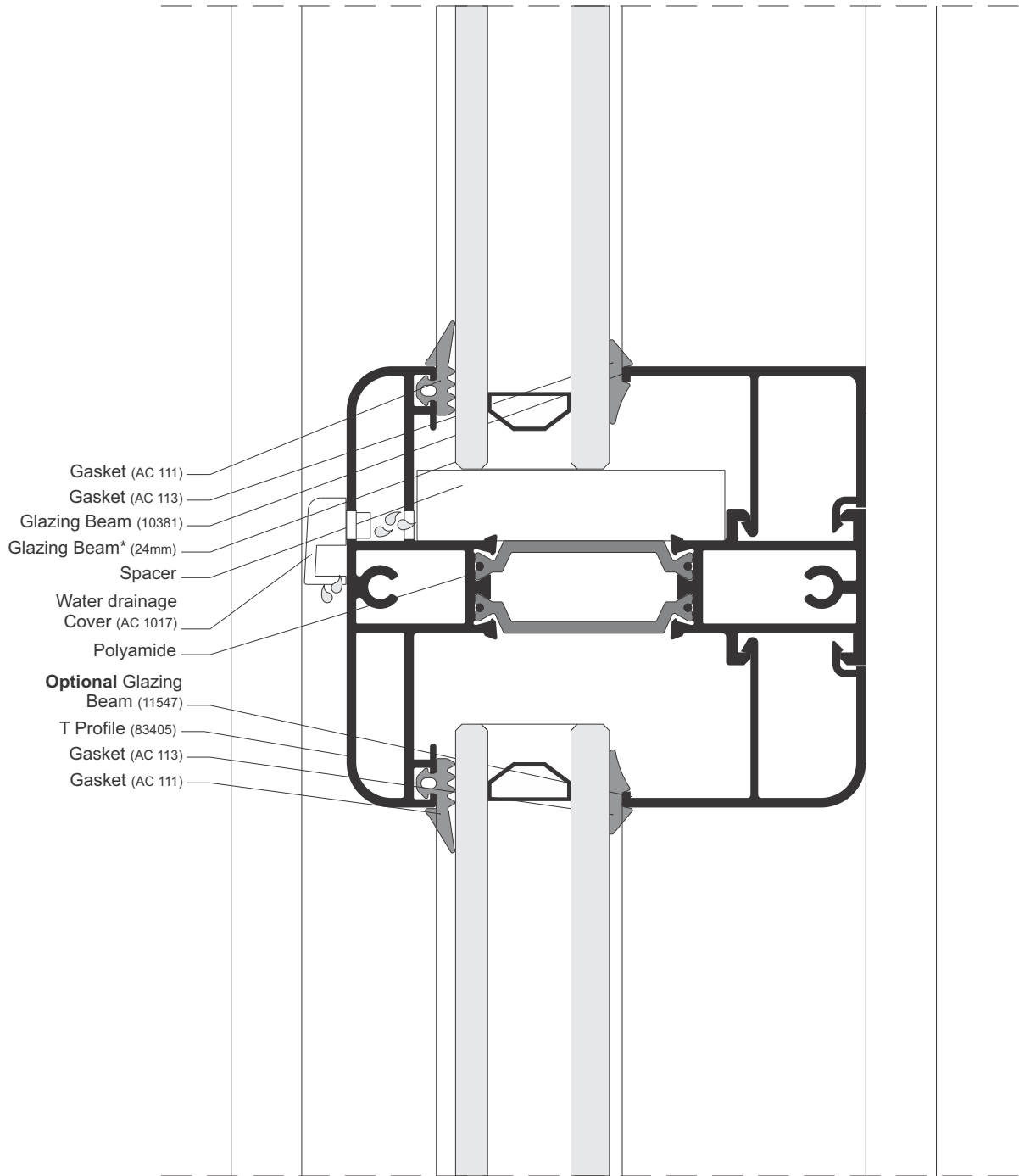

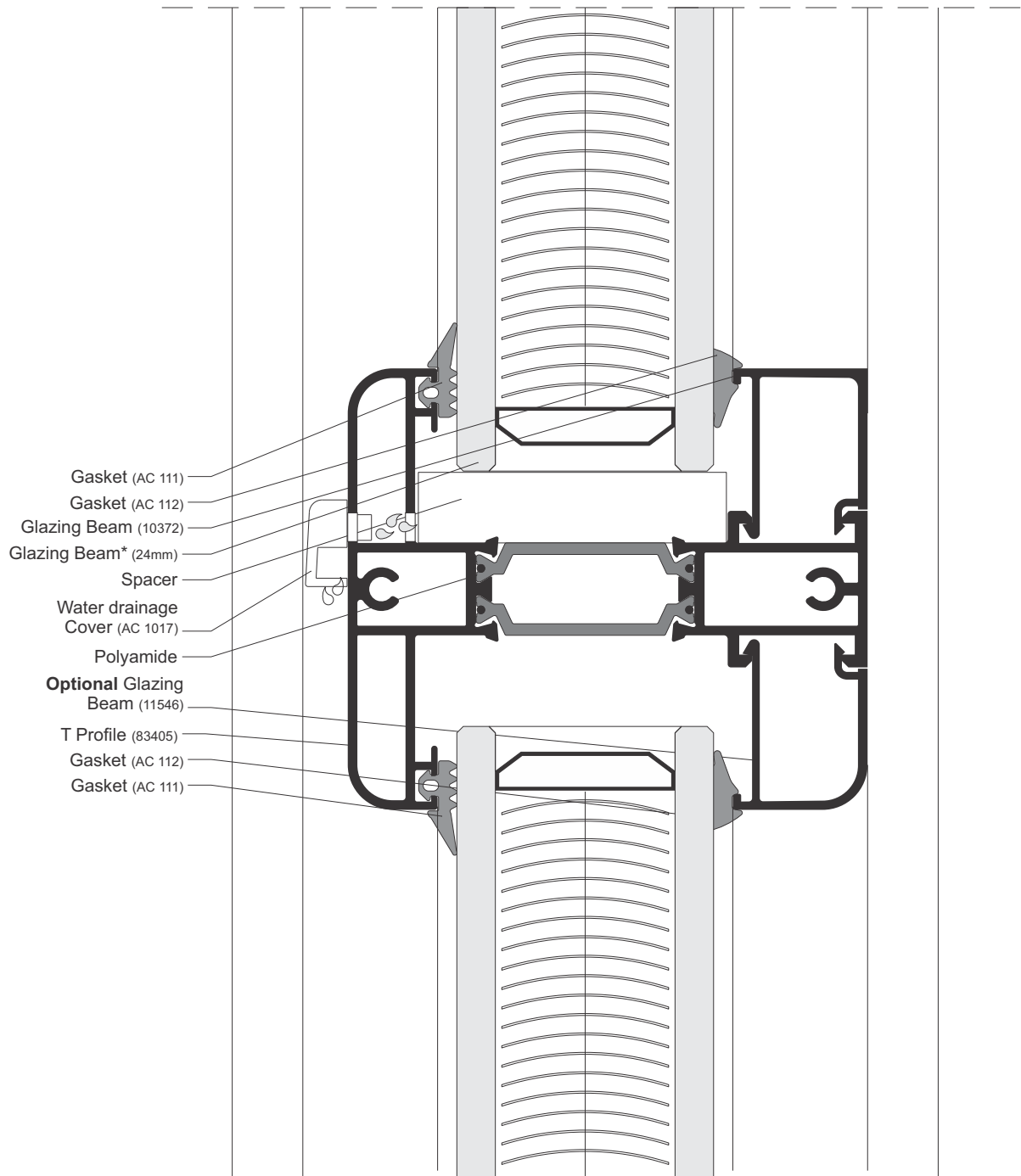

New Sliding System
Detail - B11

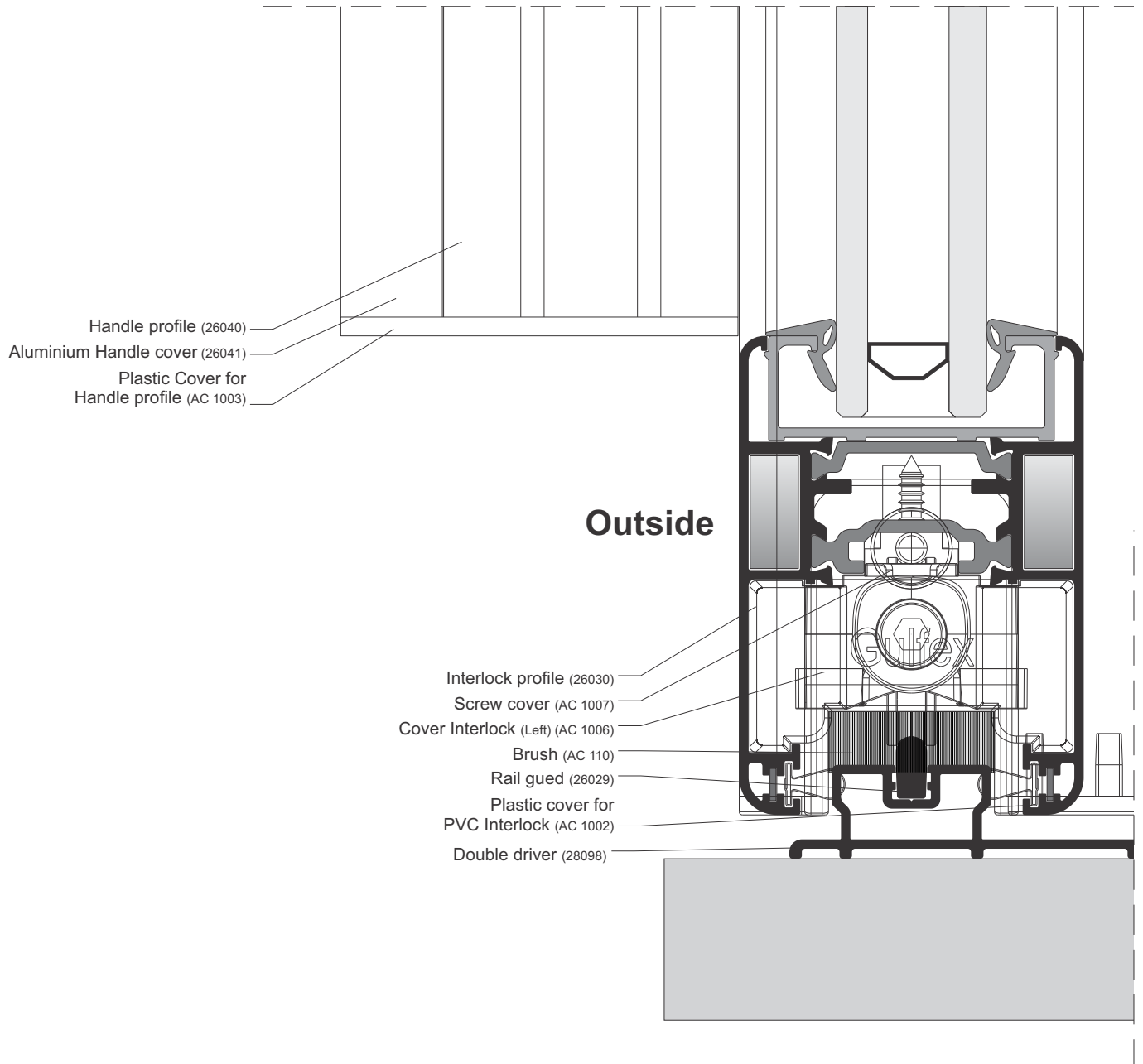

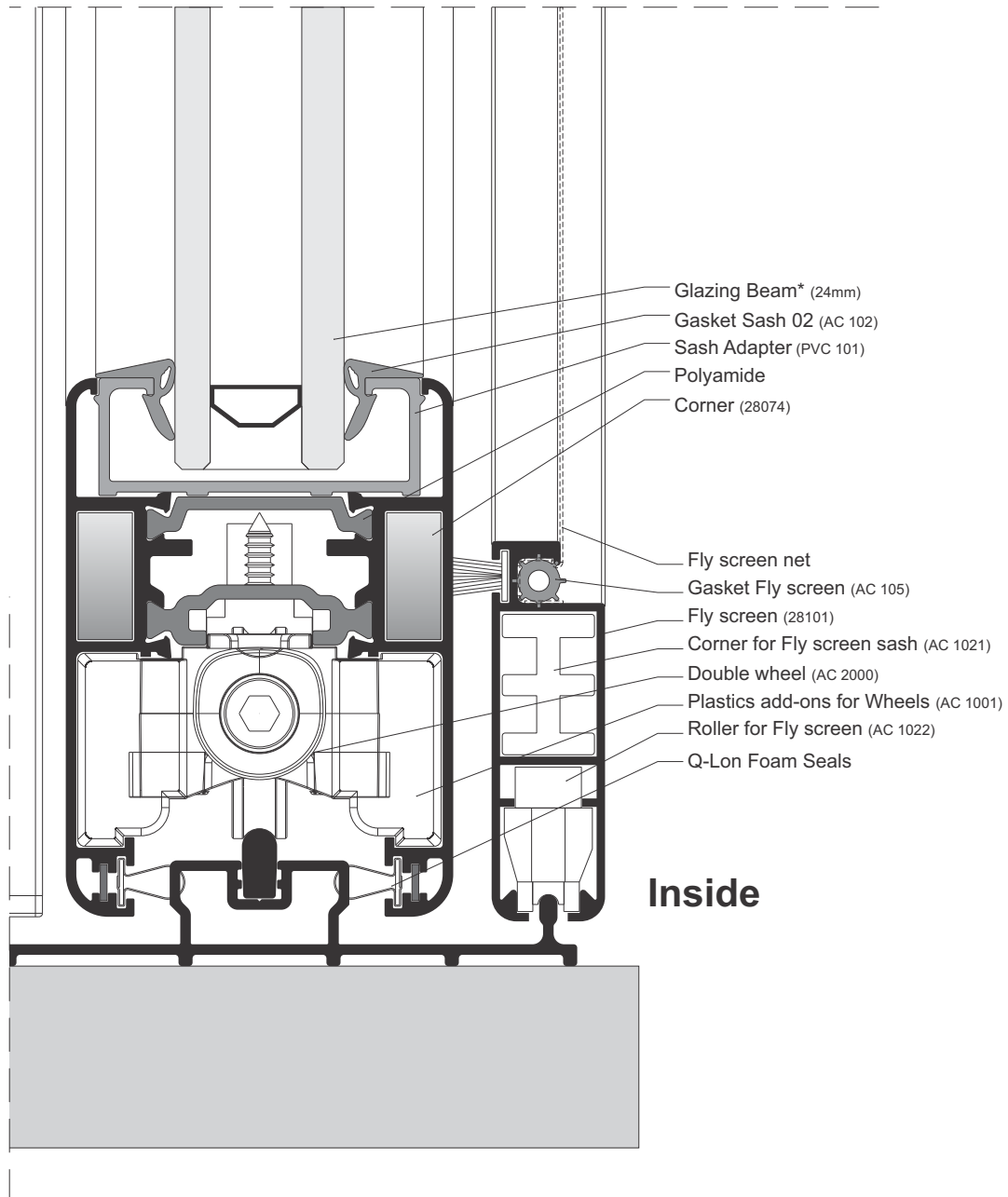

New Sliding System
Detail - B11

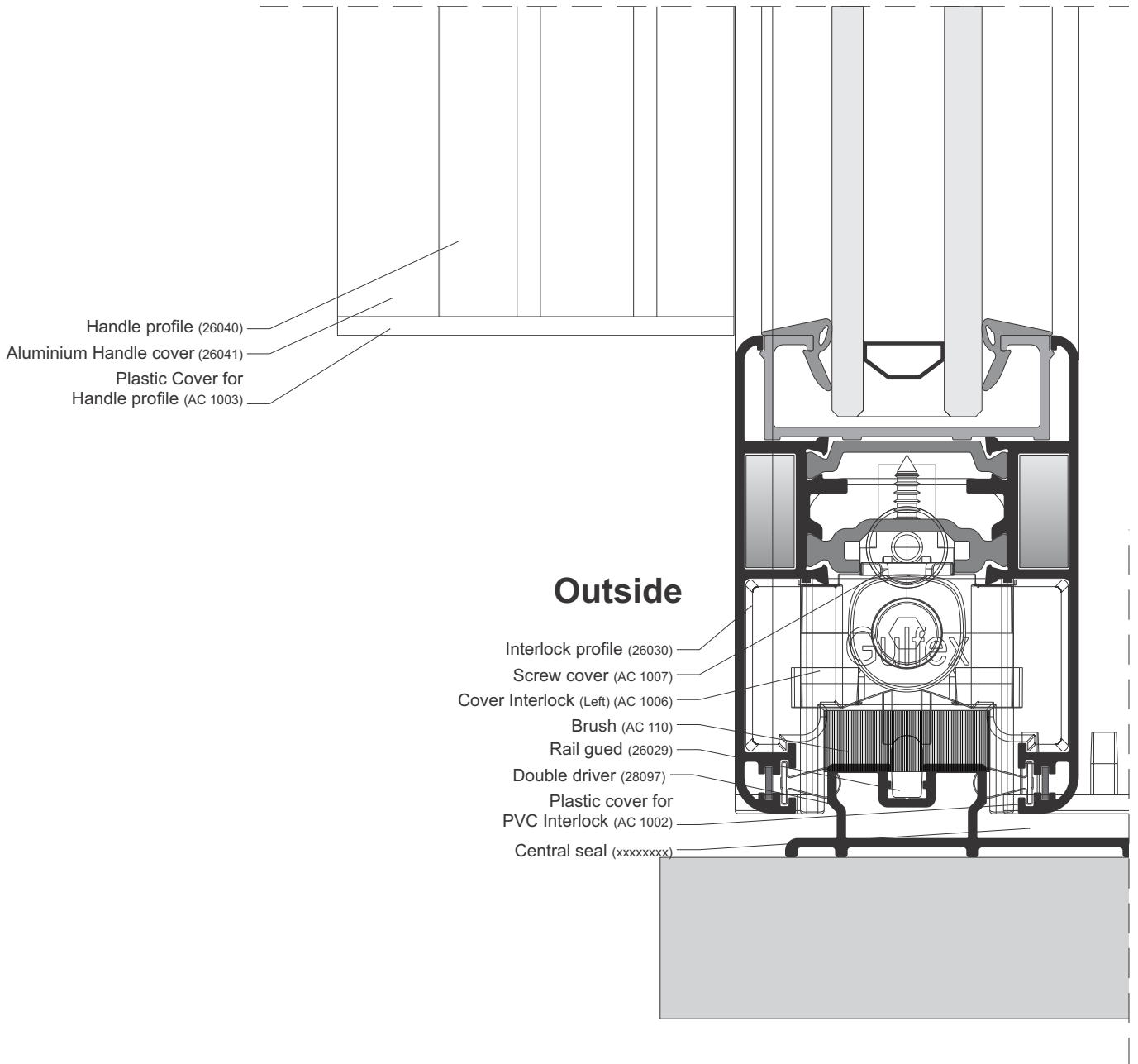



New Sliding System
Detail - B11

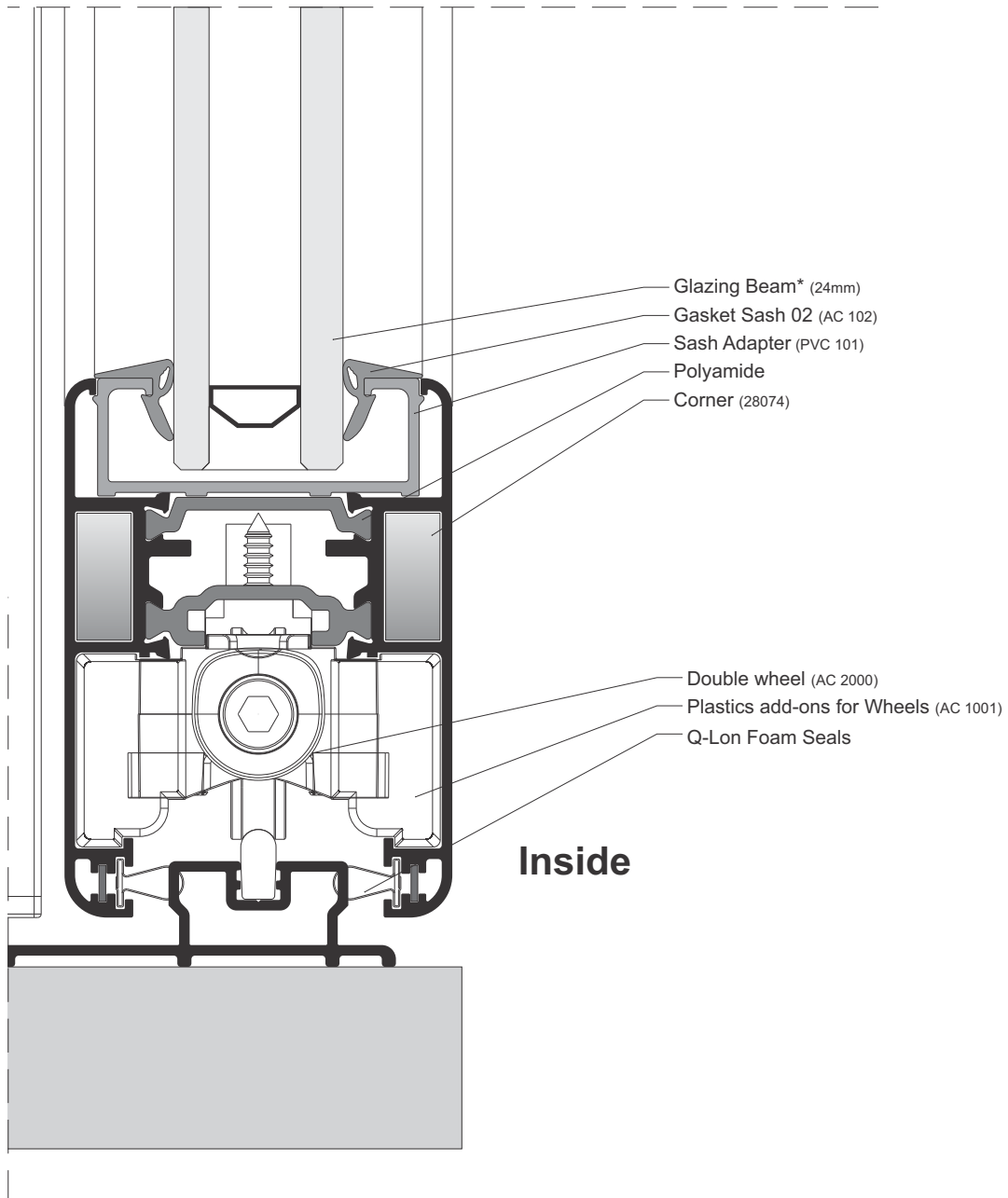

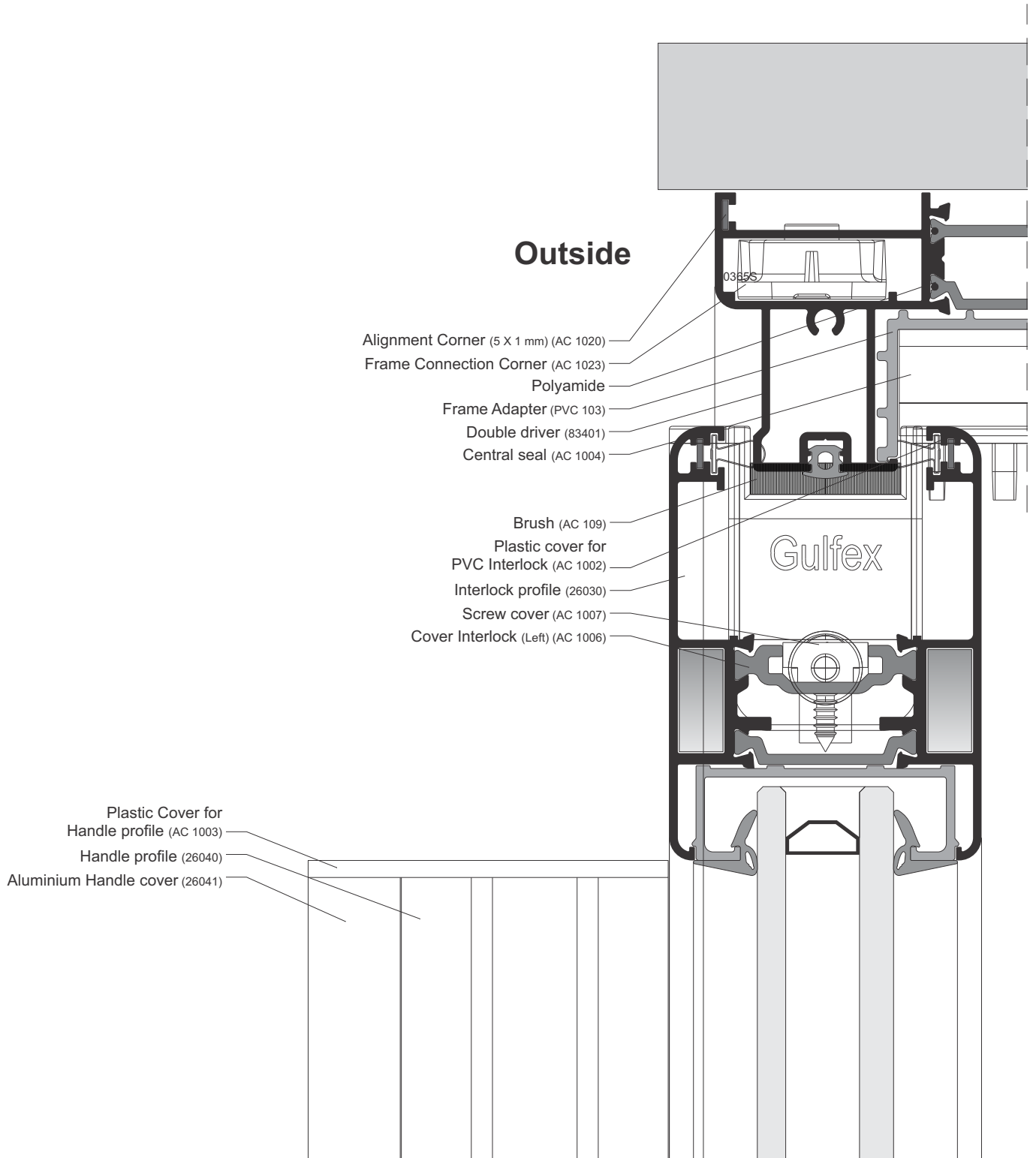

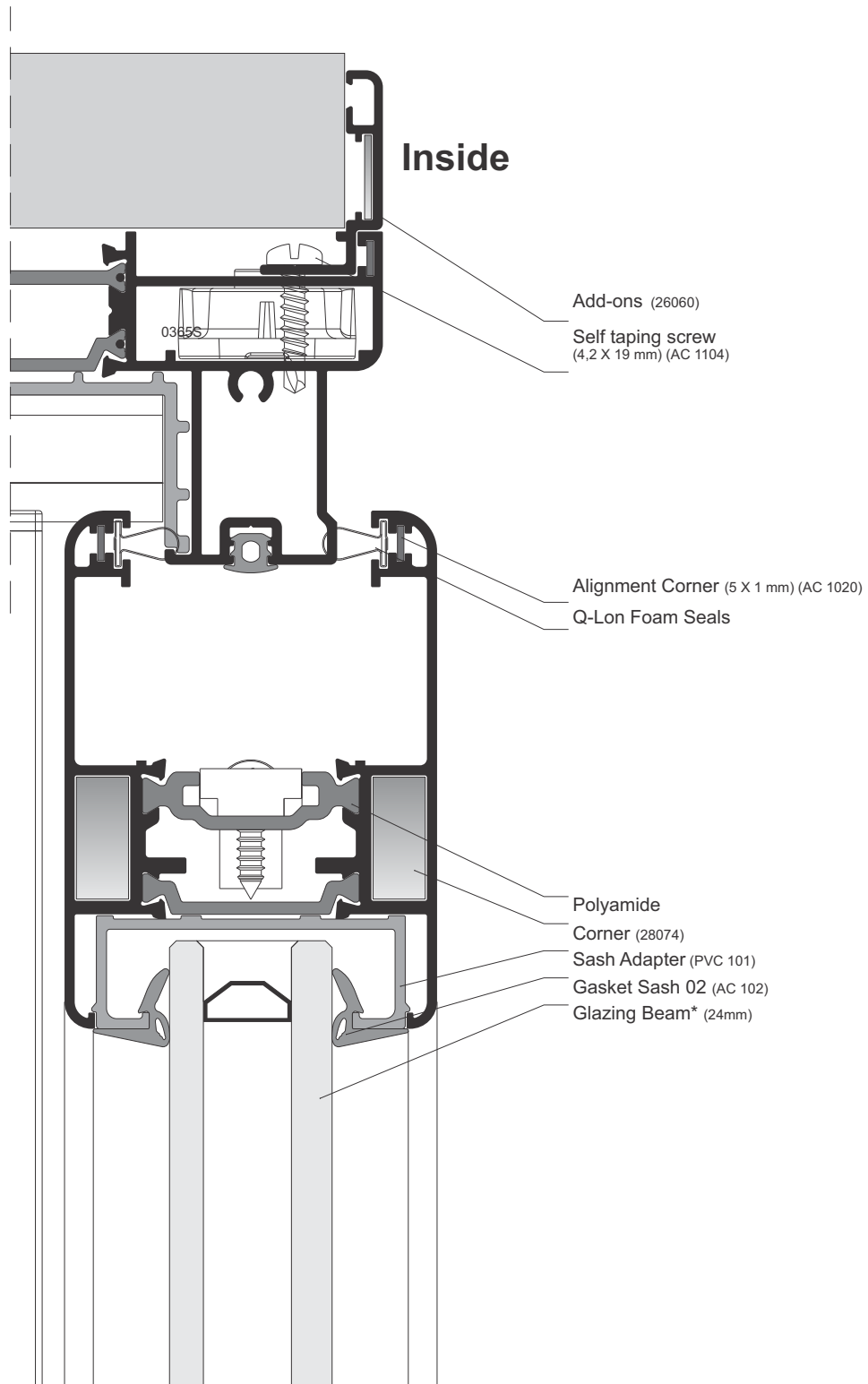

New Sliding System
Detail - A11

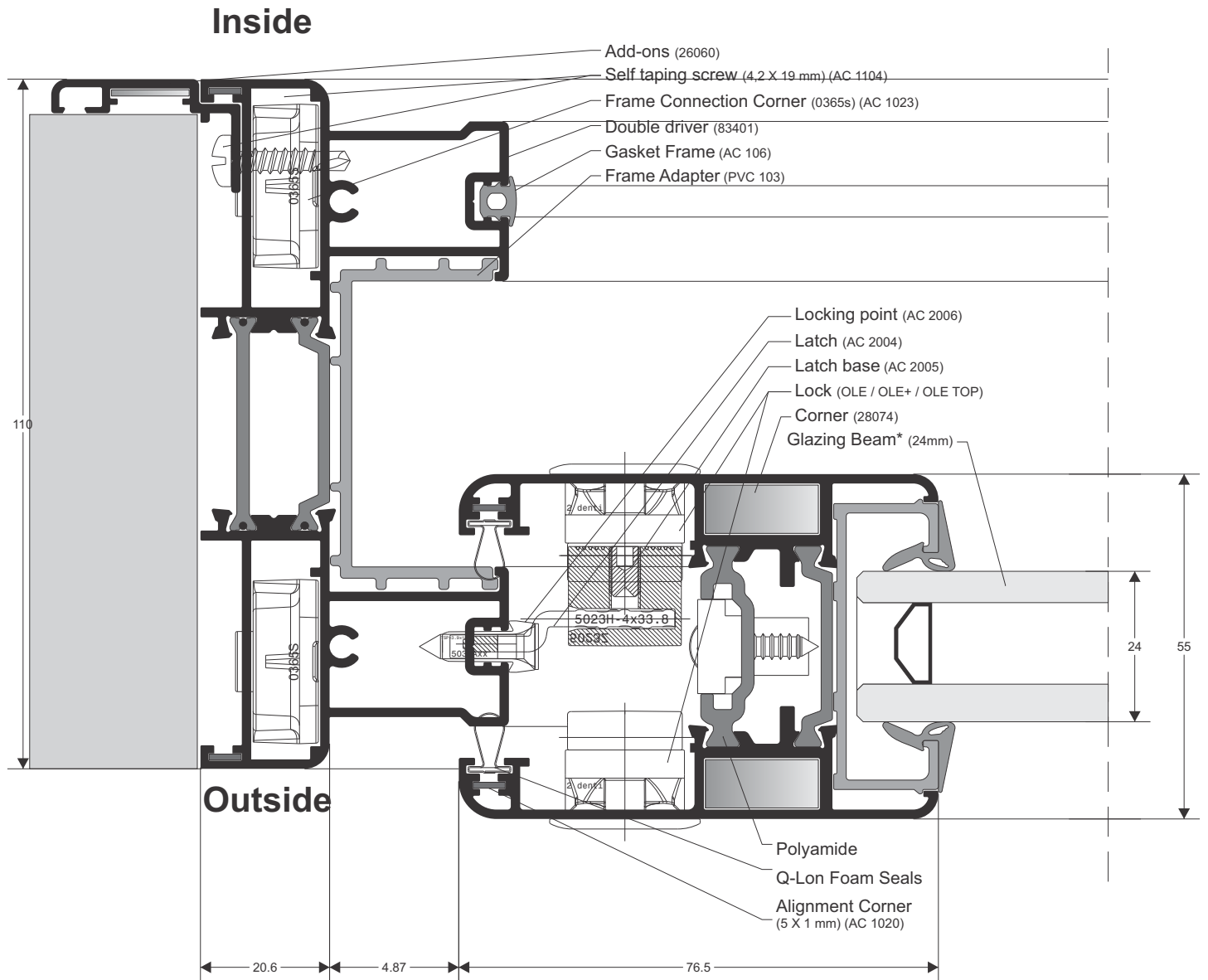

New Sliding System
Detail - A12

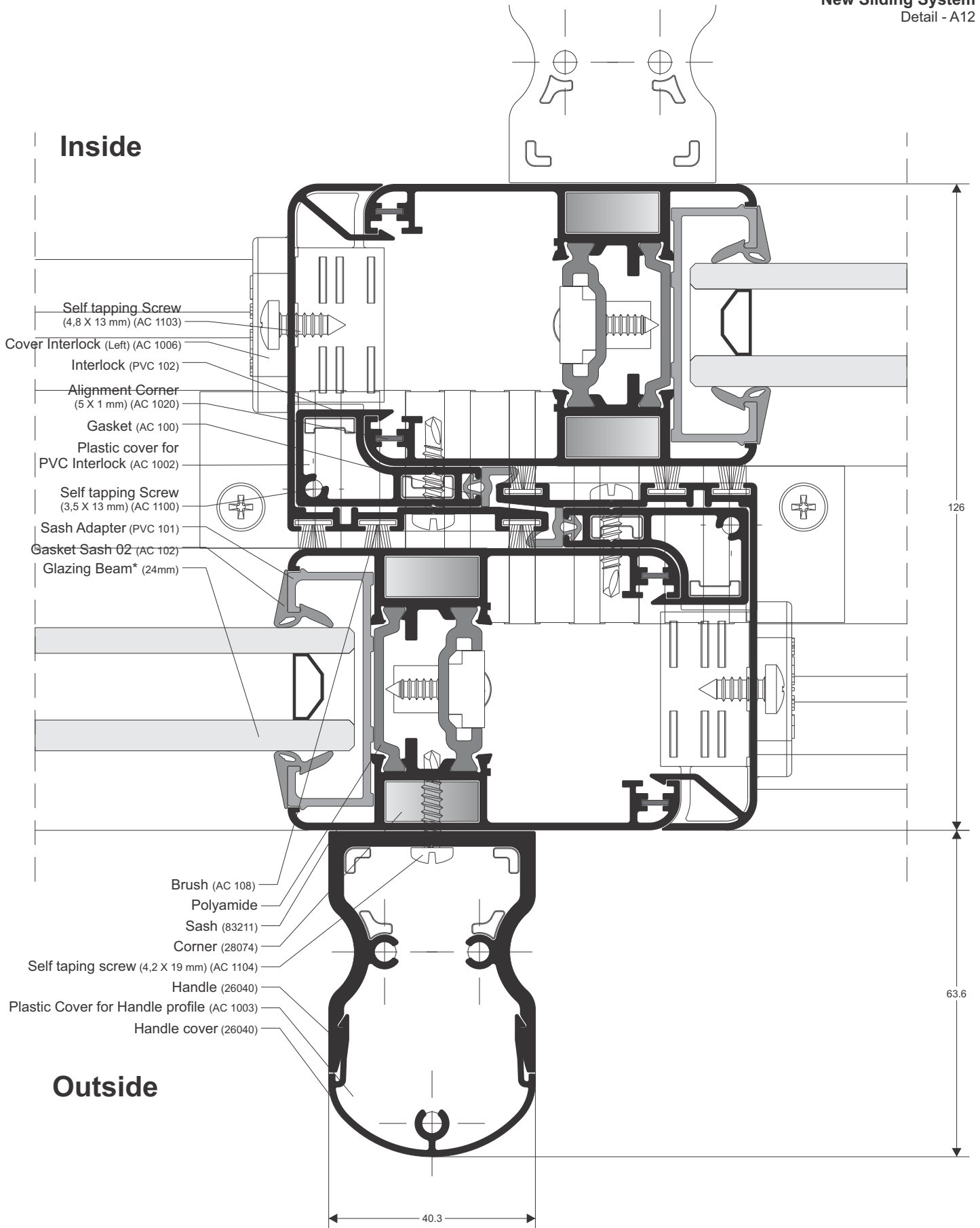

New Sliding System
Detail - A13

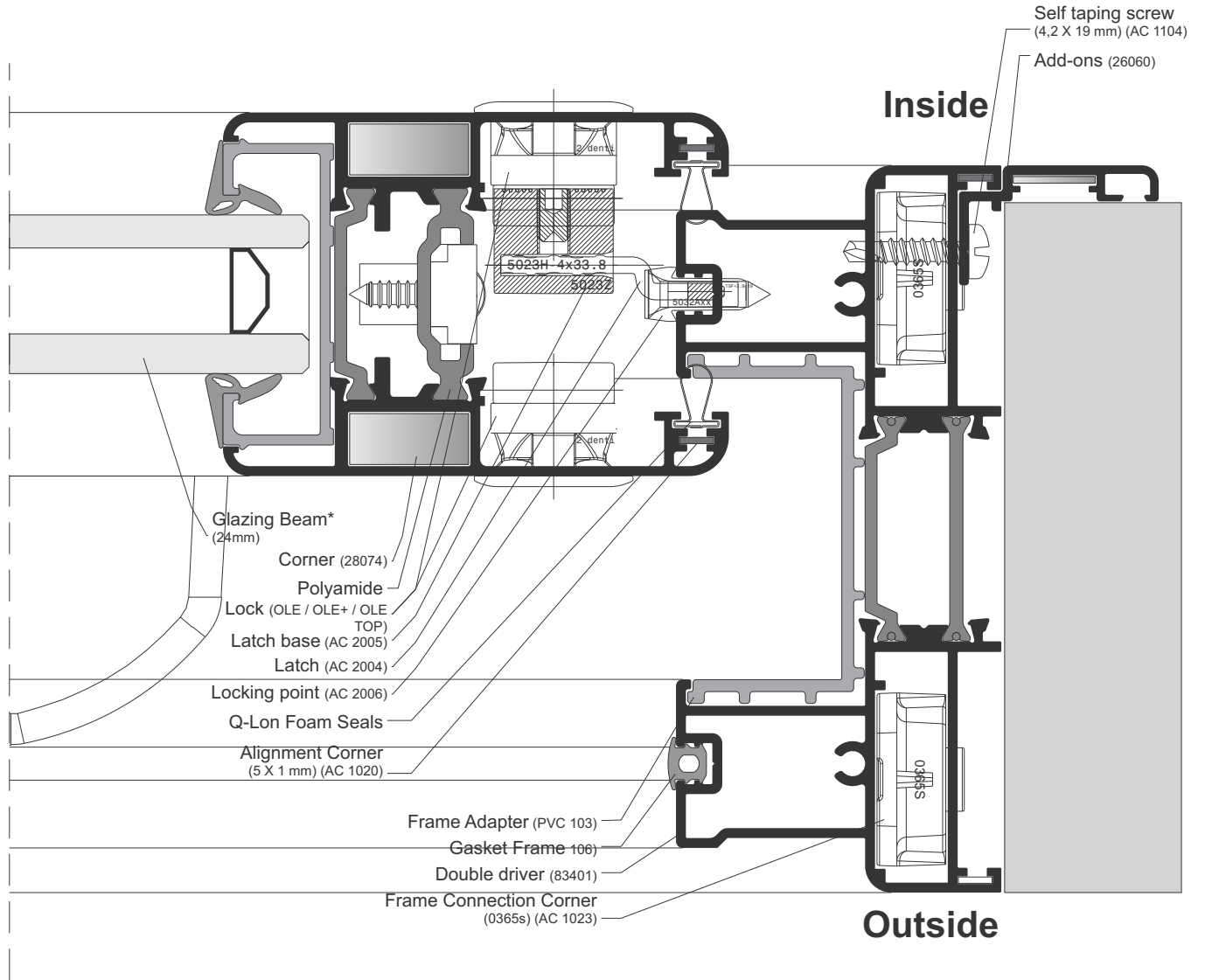

3D DETAILS

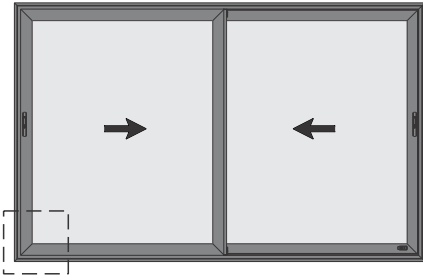

Outside

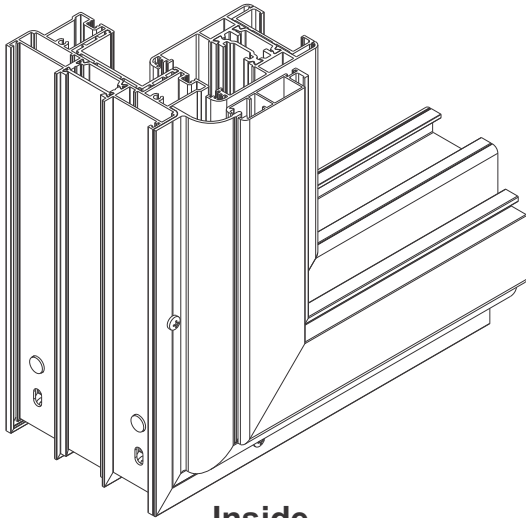

Inside

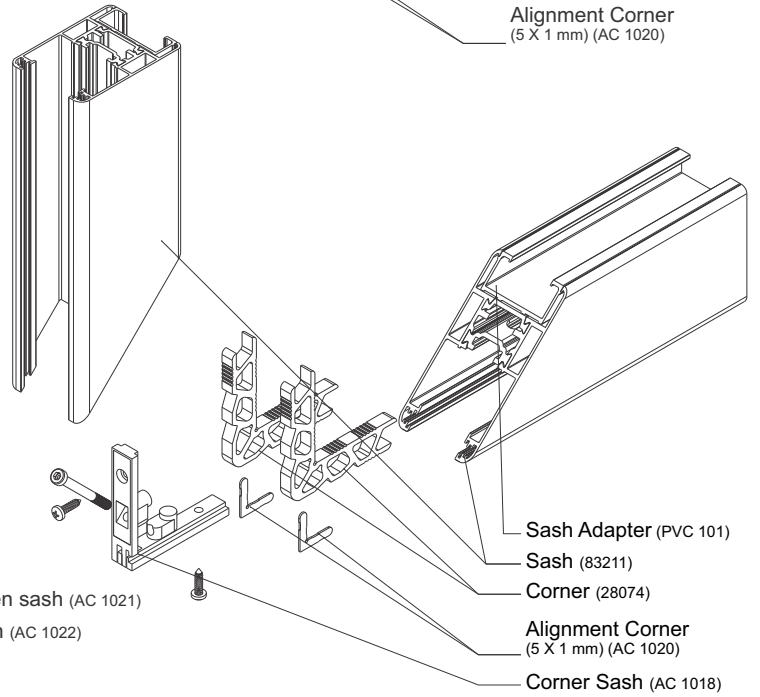
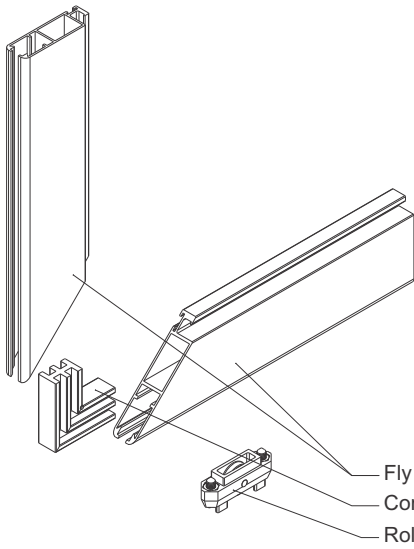
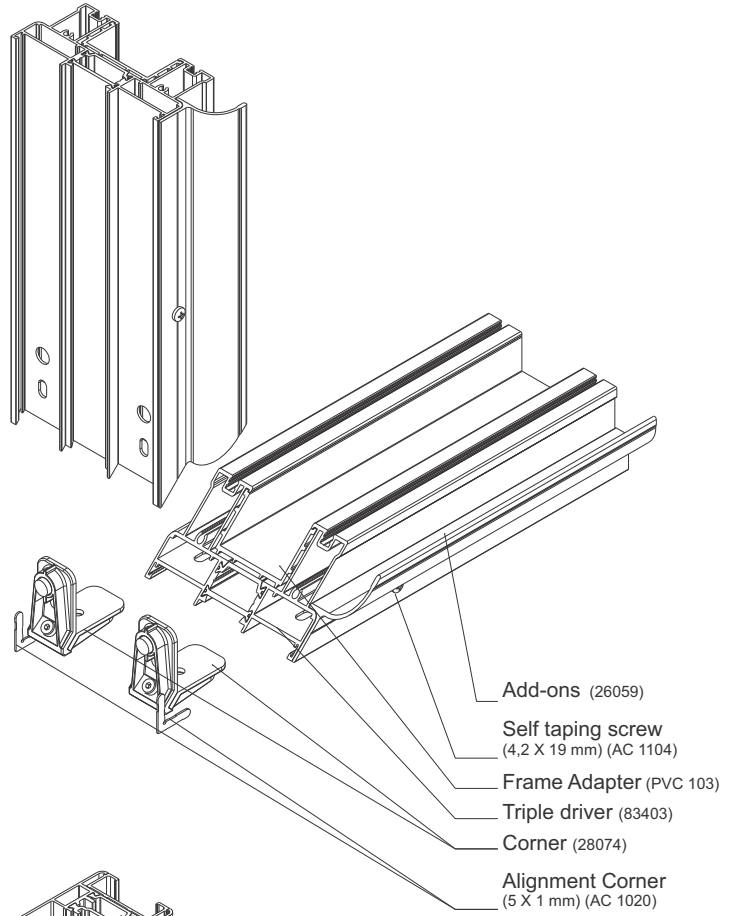

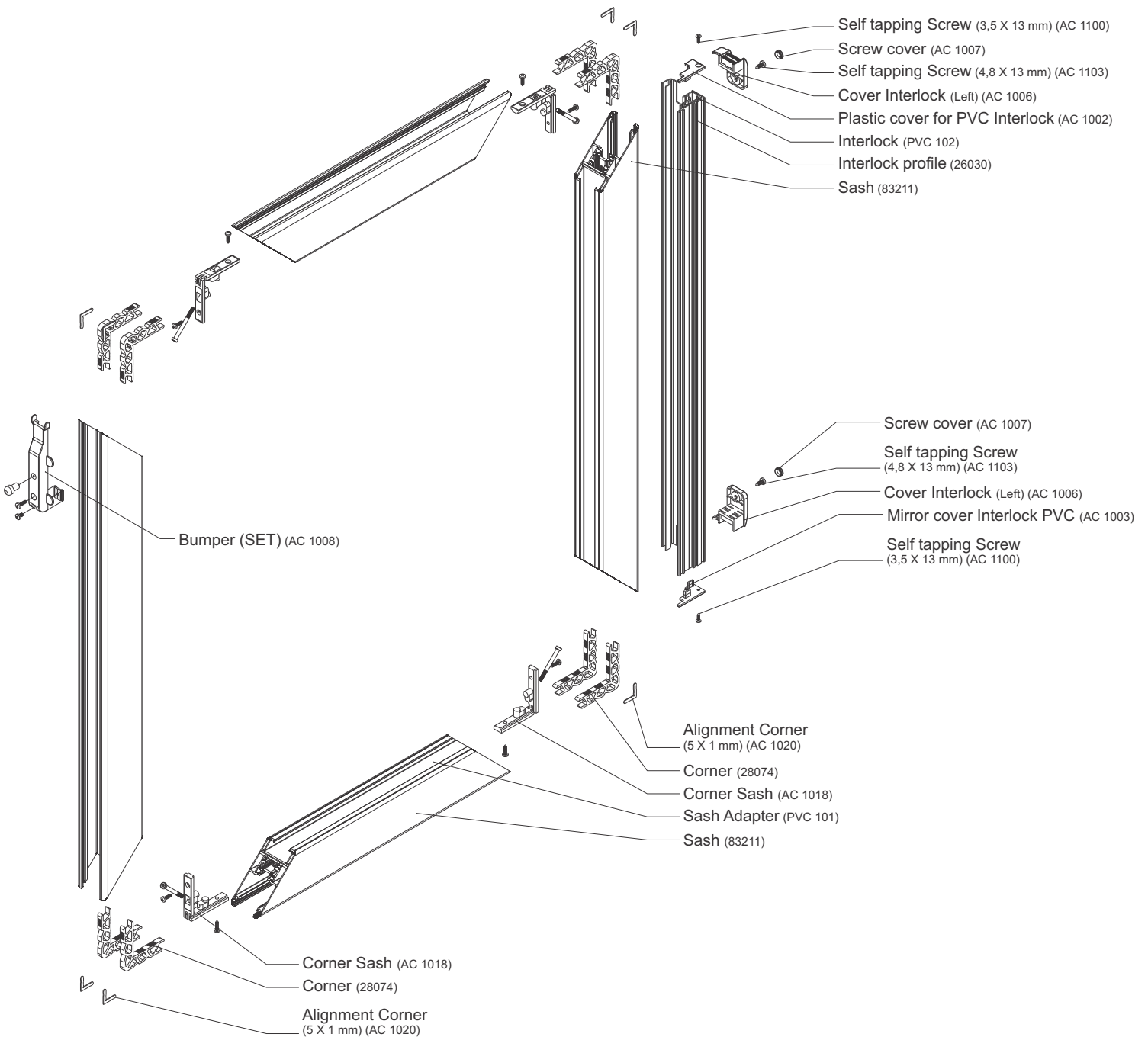
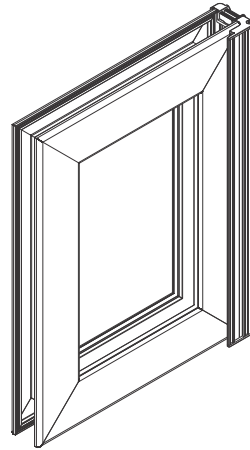
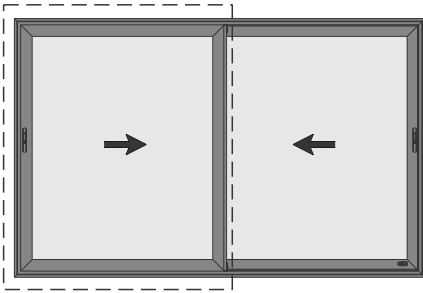

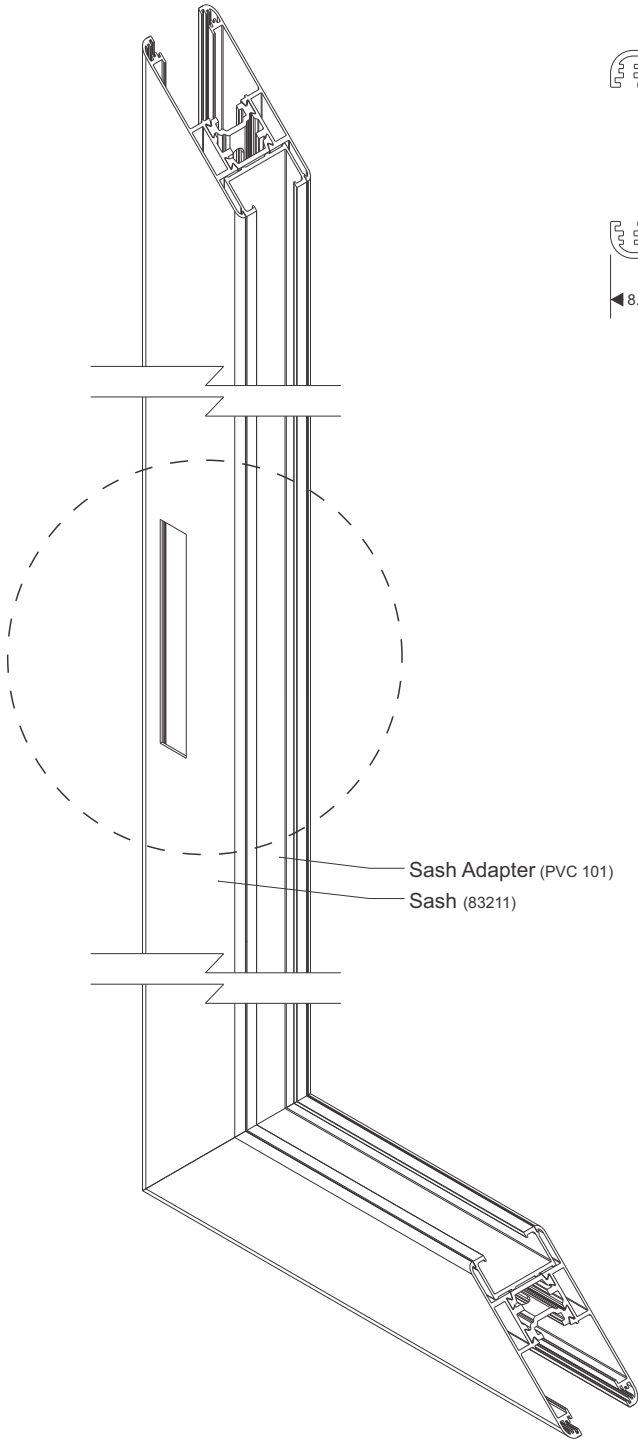
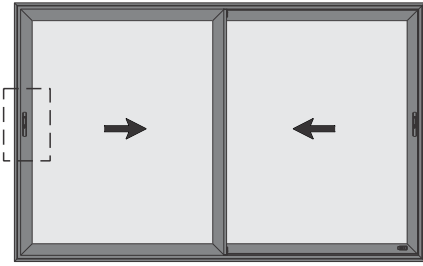

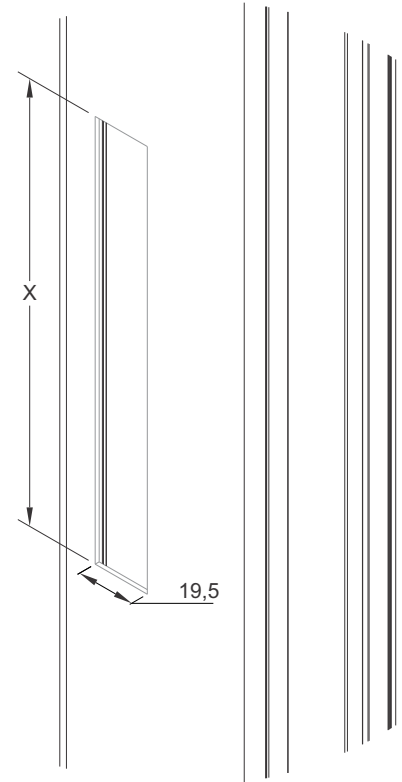
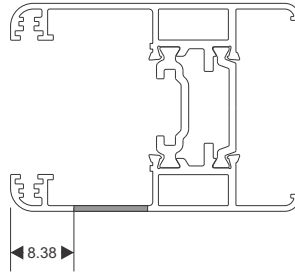

Sash Adapter (PVC 101)
Sash (83211)



| | | |
|---|-----------------------------------|---------|
|  | 5000BA - 5000BB - 5000BC 70153 | X=145mm |
|  | 5000BA - 5000BB - 5000BC 79982 | X=185mm |
|  | 5000BA - 5000BB - 5000BC 92070 | X=185mm |

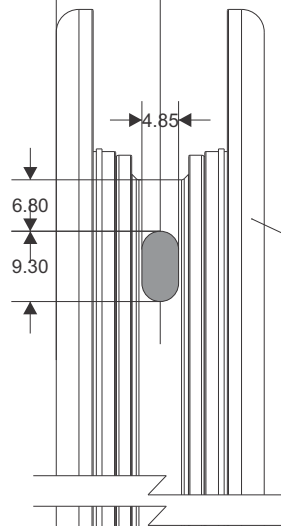
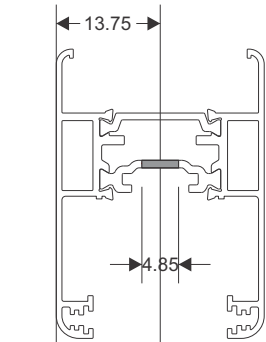
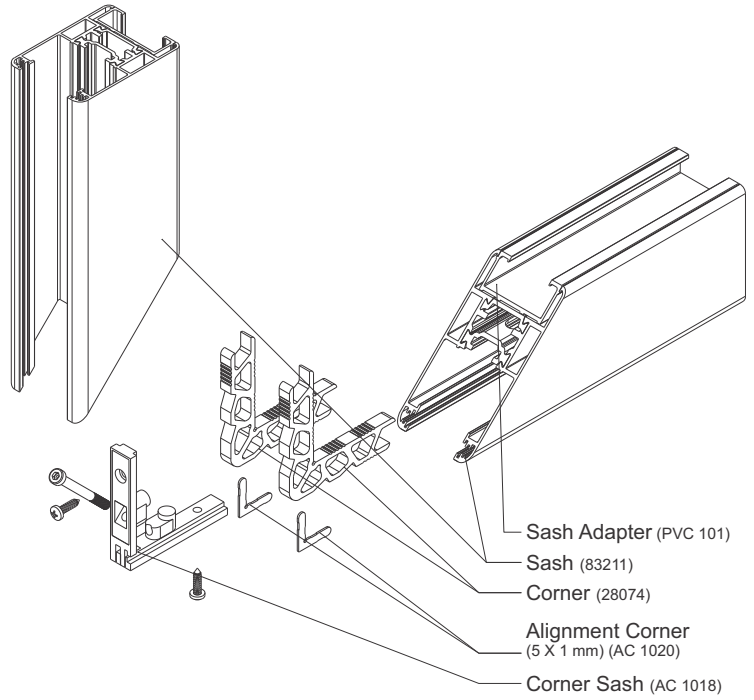
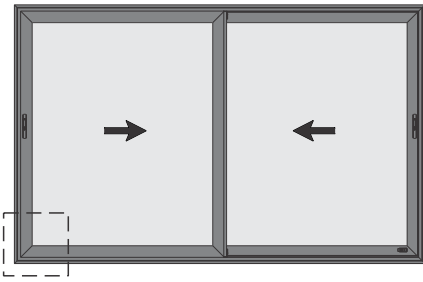

Sash (83211)

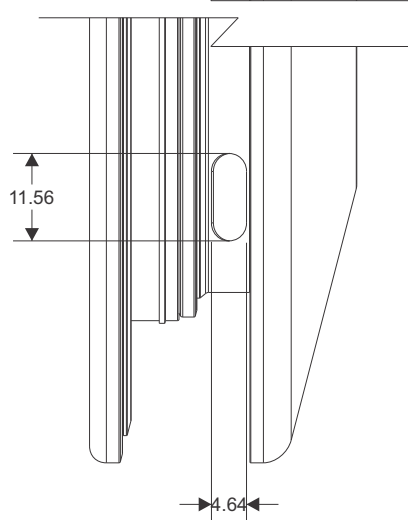
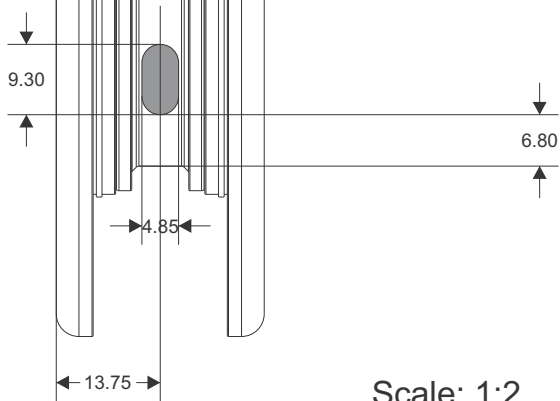
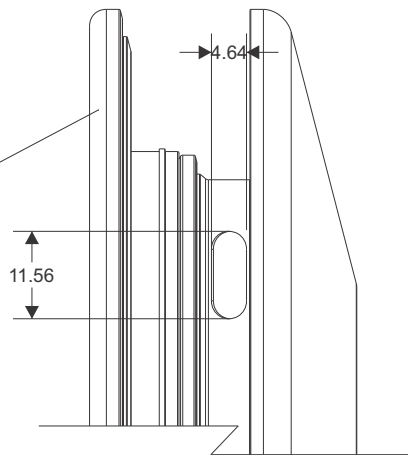

Scale: 1:2

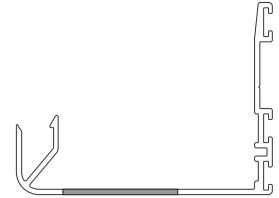
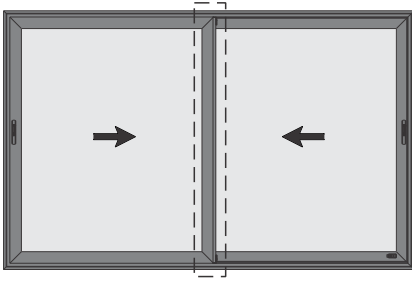

- Self tapping Screw (3,5 X 13 mm) (AC 1100)
- Cover Interlock (Left) (AC 1006)
- Screw cover (AC 1007)
- Self tapping Screw (4,8 X 13 mm) (AC 1103)
- Plastic cover for PVC Interlock (AC 1002)
- Interlock (PVC 102)
- Interlock profile (26030)

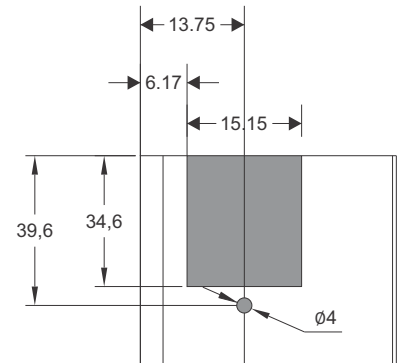
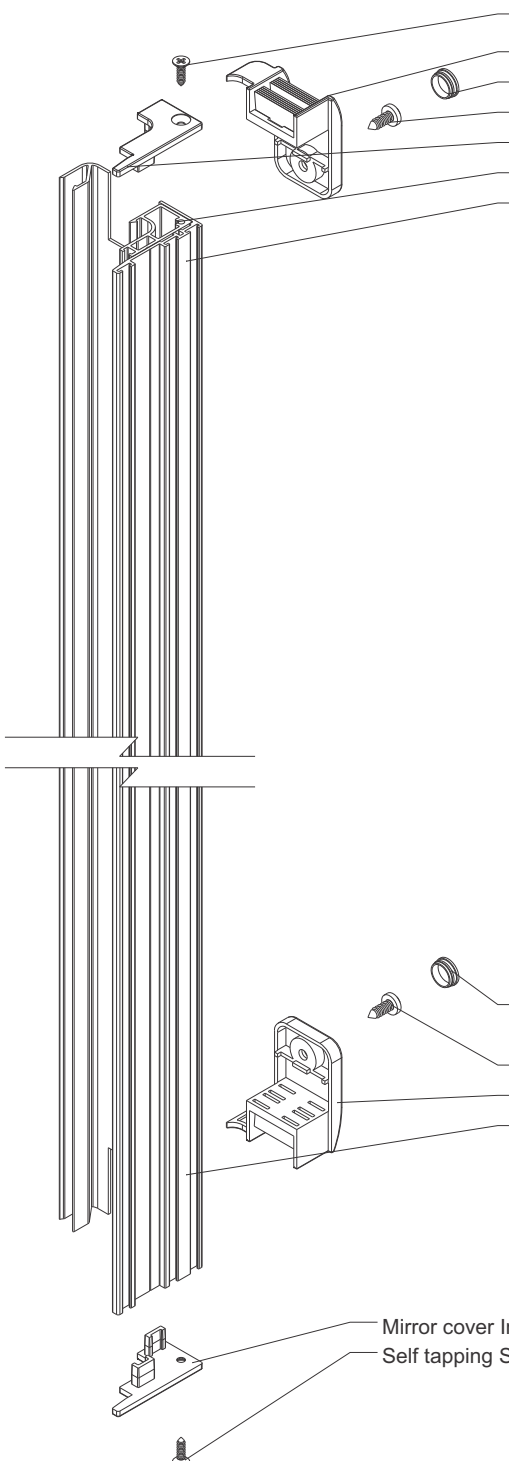

Interlock profile (26030)

- Screw cover (AC 1007)
- Self tapping Screw (4,8 X 13 mm) (AC 1103)
- Cover Interlock (Left) (AC 1006)
- Interlock profile (26030)

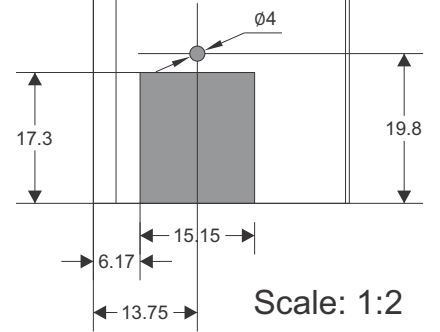

Scale: 1:2

- Mirror cover Interlock PVC (AC 1003)
- Self tapping Screw (3,5 X 13 mm) (AC 1100)

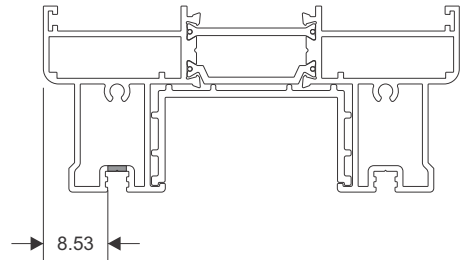
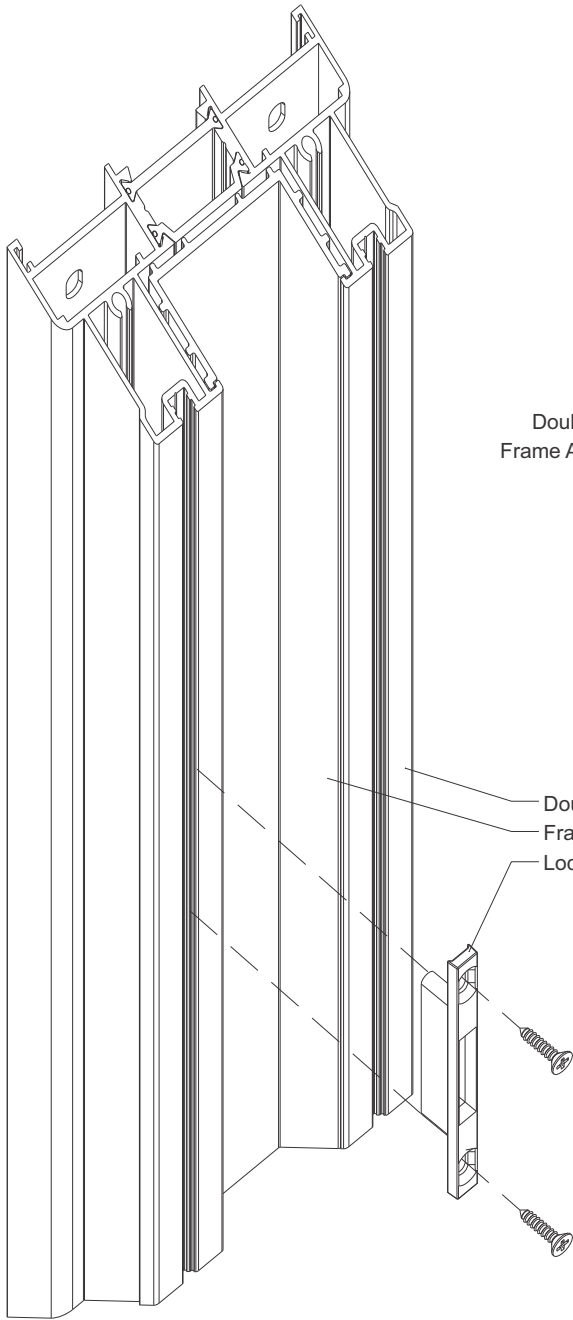
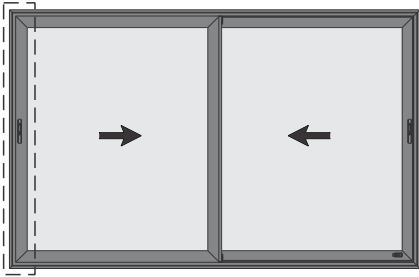

Double driver (83401)
Frame Adapter (PVC 103)

Double driver (83401)
Frame Adapter (PVC 103)
Locking point (AC 2006)

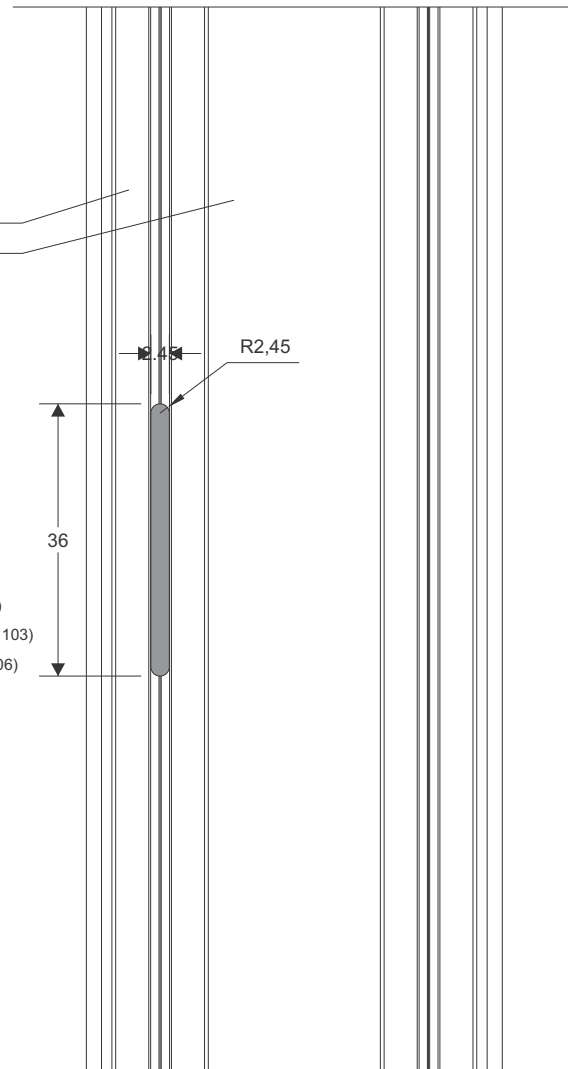

Scale: 1:2

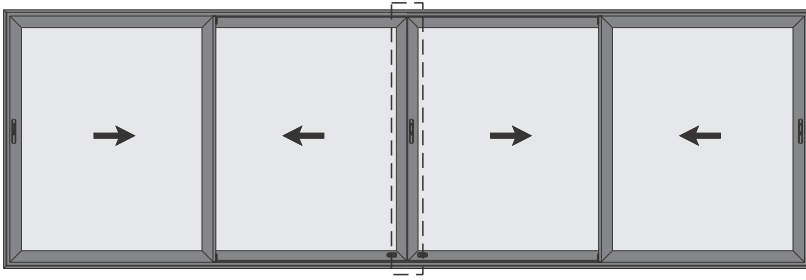

This add on profile is installed before the sash corner are assembled.

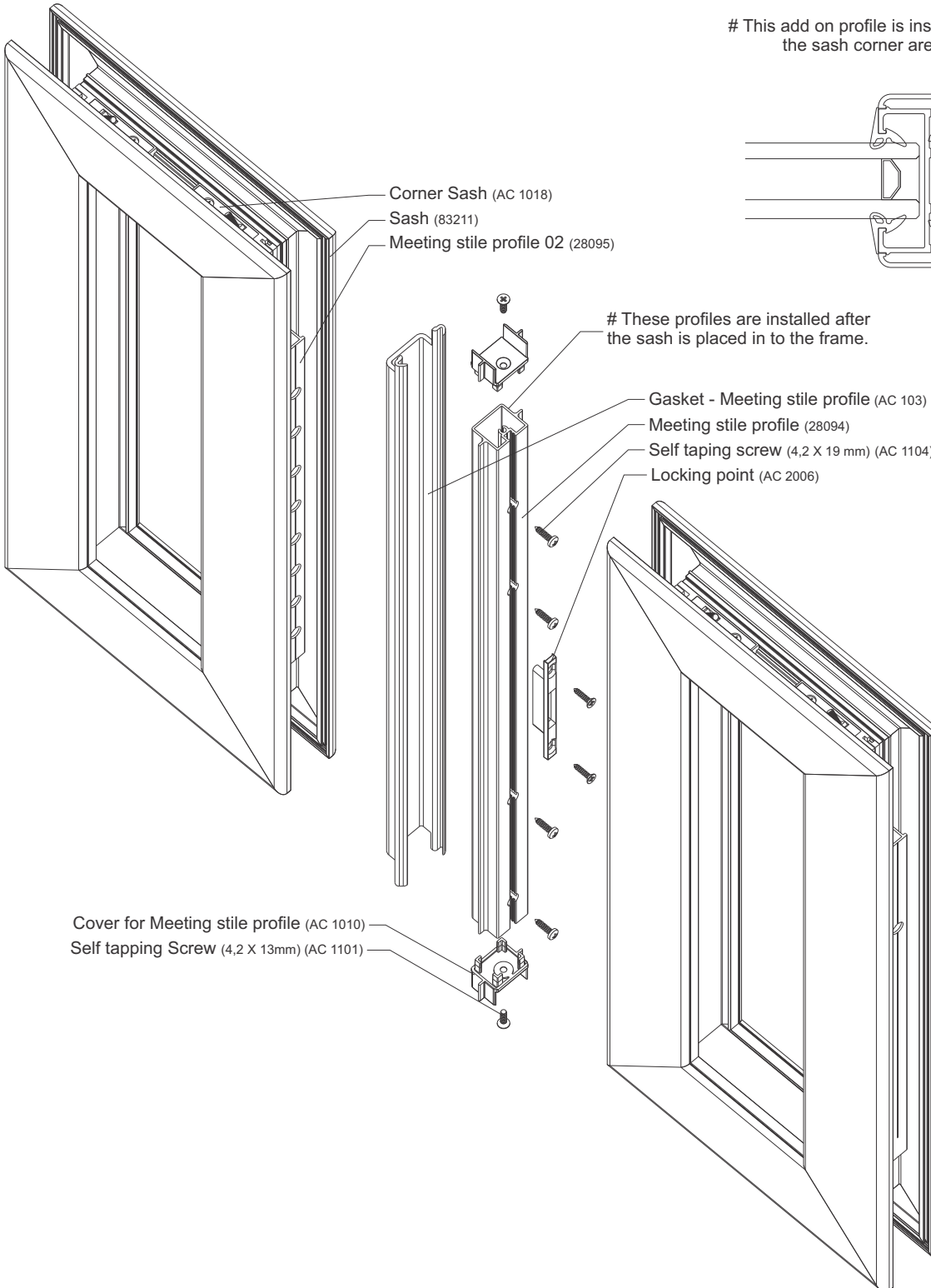
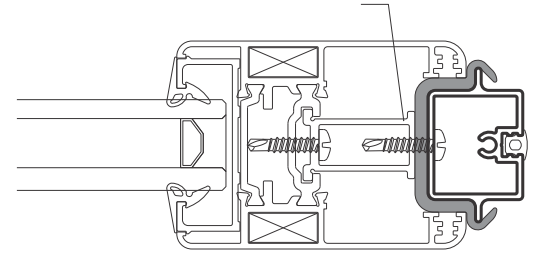

- Corner Sash (AC 1018)
- Sash (83211)
- Meeting stile profile 02 (28095)

These profiles are installed after the sash is placed in to the frame.

- Gasket - Meeting stile profile (AC 103)
- Meeting stile profile (28094)
- Self tapping screw (4,2 X 19 mm) (AC 1104)
- Locking point (AC 2006)

- Cover for Meeting stile profile (AC 1010)
- Self tapping Screw (4,2 X 13mm) (AC 1101)

Scale: 1:2

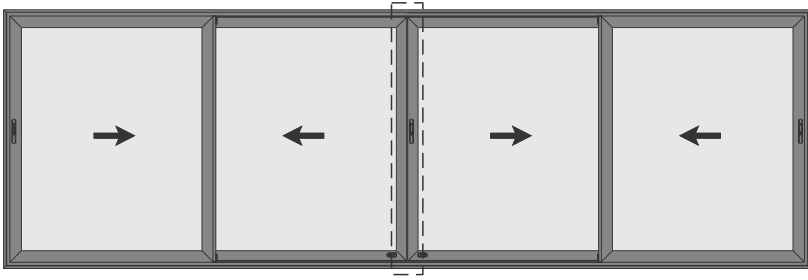

| Cutting table | |
|---|-------------------------|
| Meeting stile profile (28094) | X = Sash height - 37mm |
| Gasket - Meeting stile profile (AC 103) | Y = Sash height |
| Meeting stile profile 02 (28095) | Z = Sash height - 230mm |

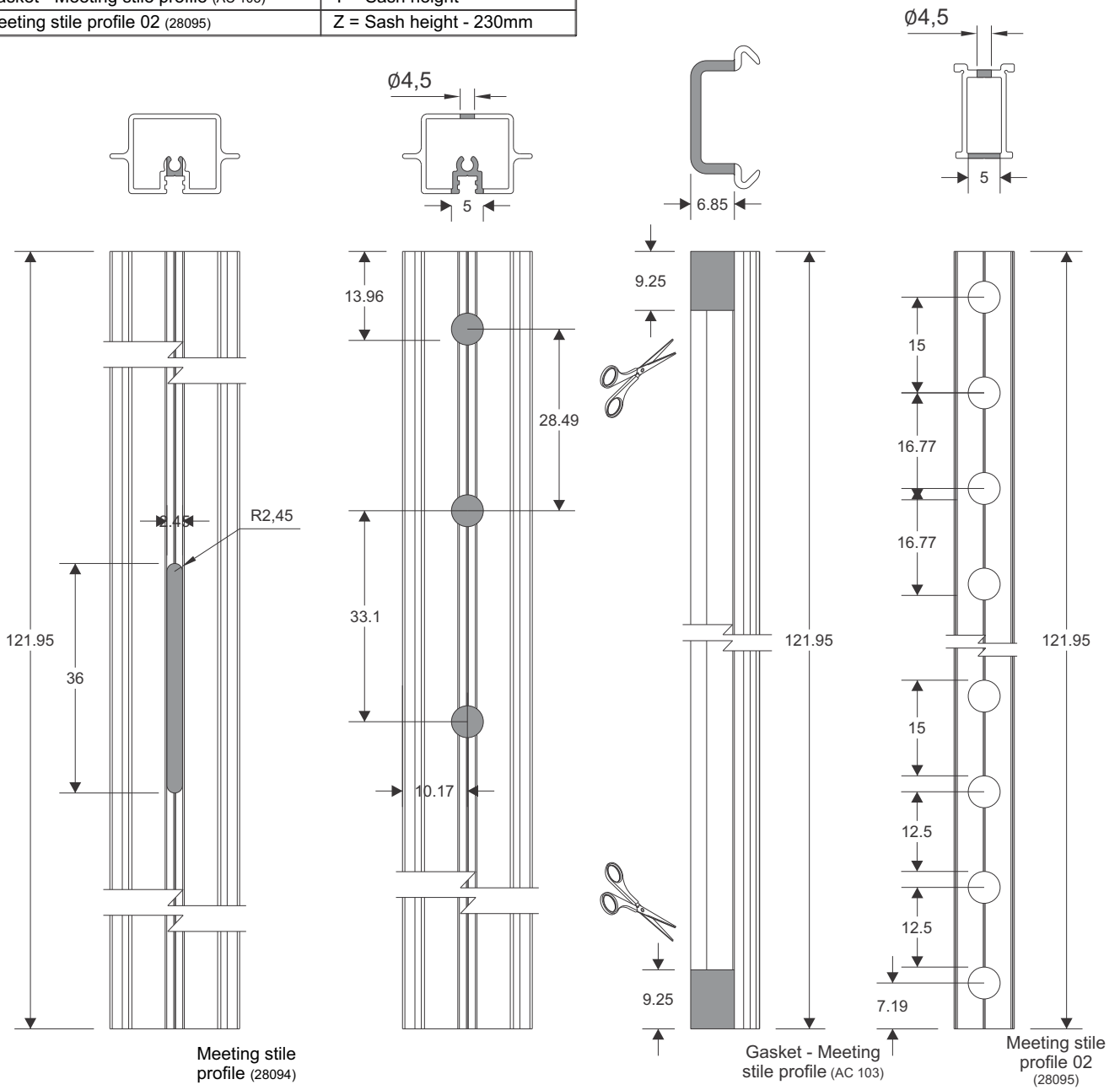

Scale: 1:2

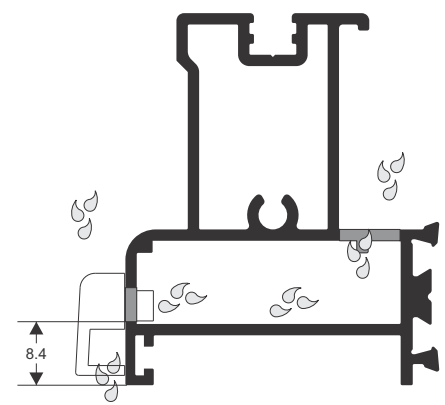
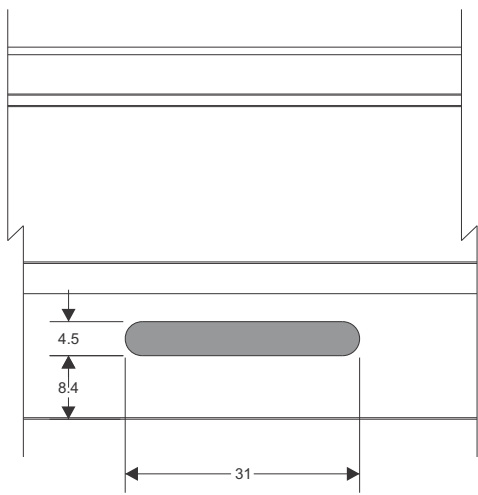
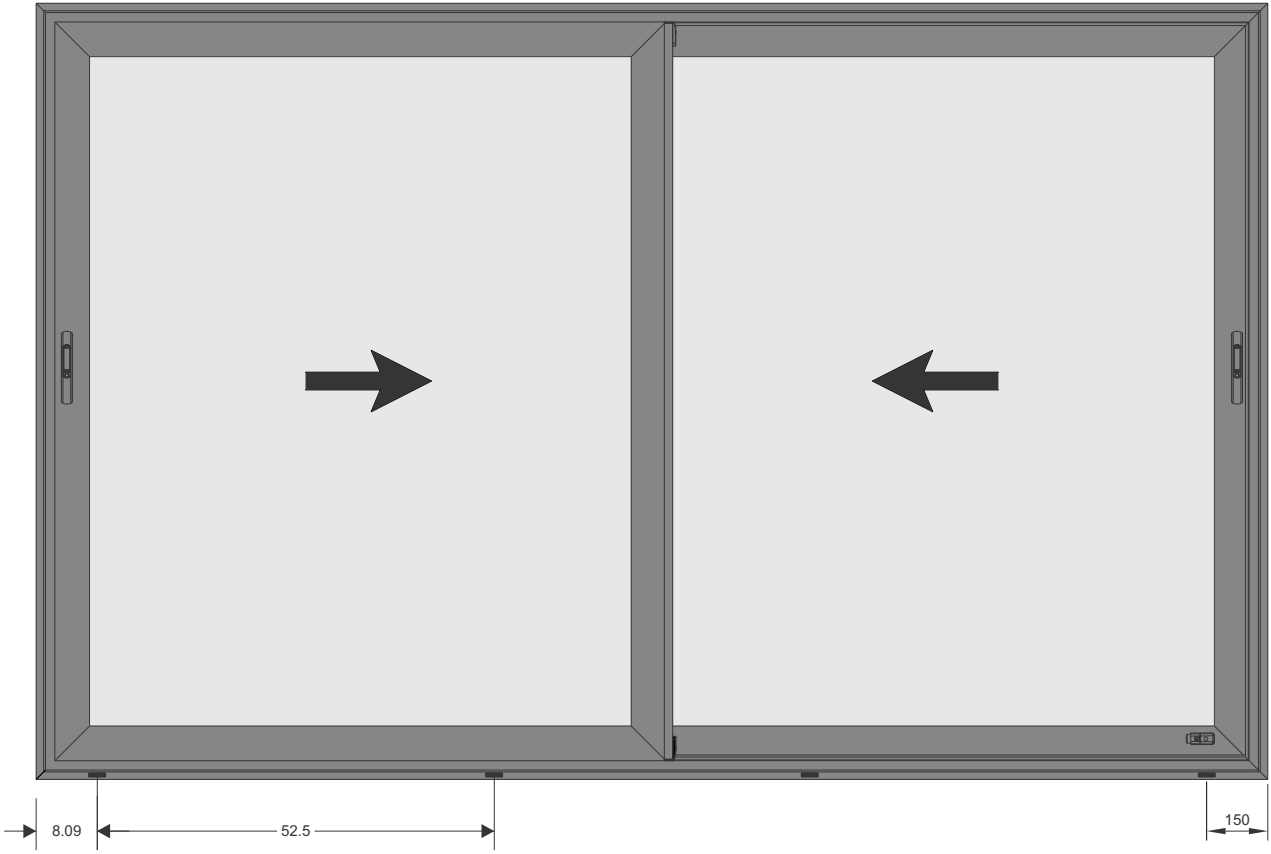

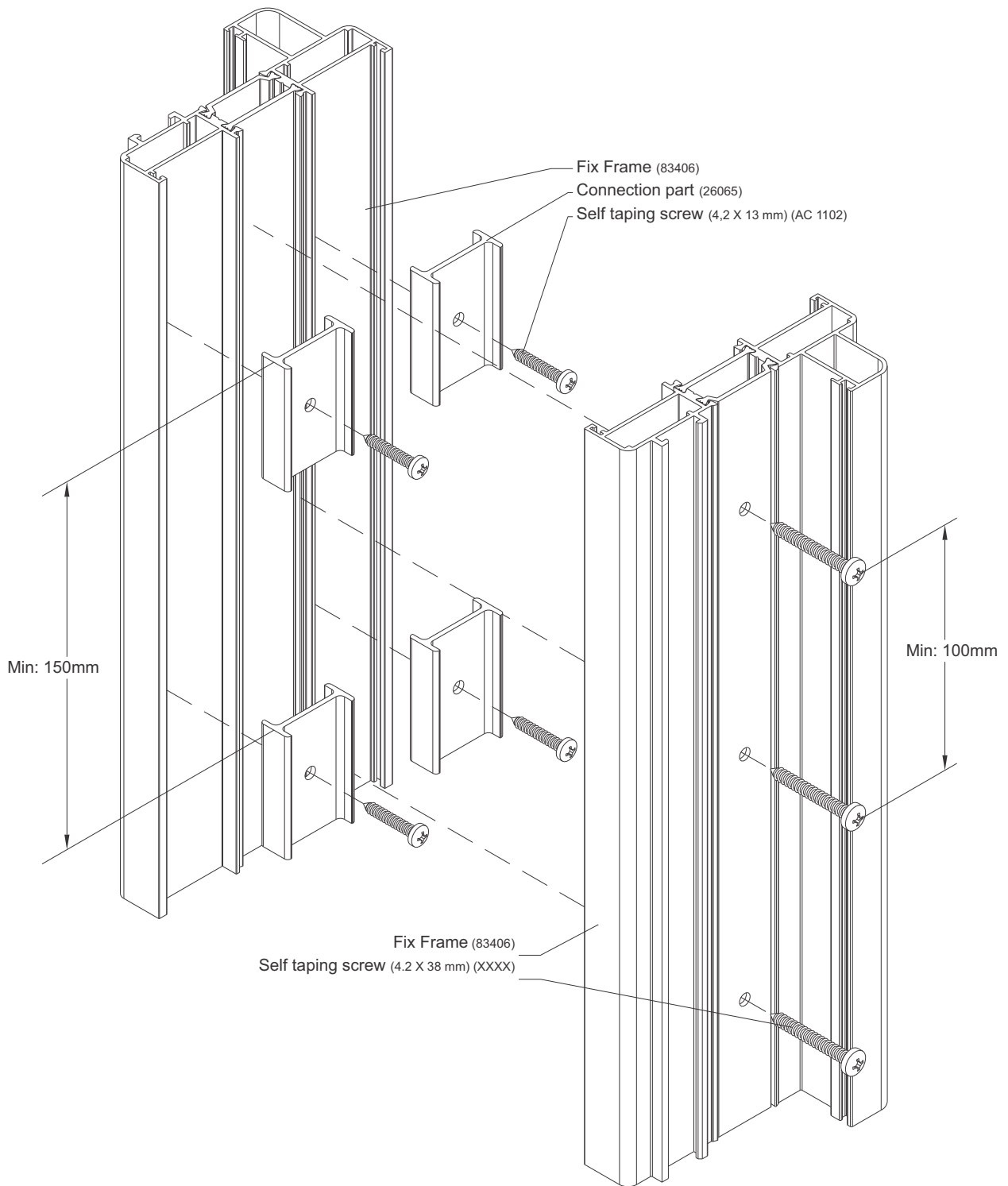

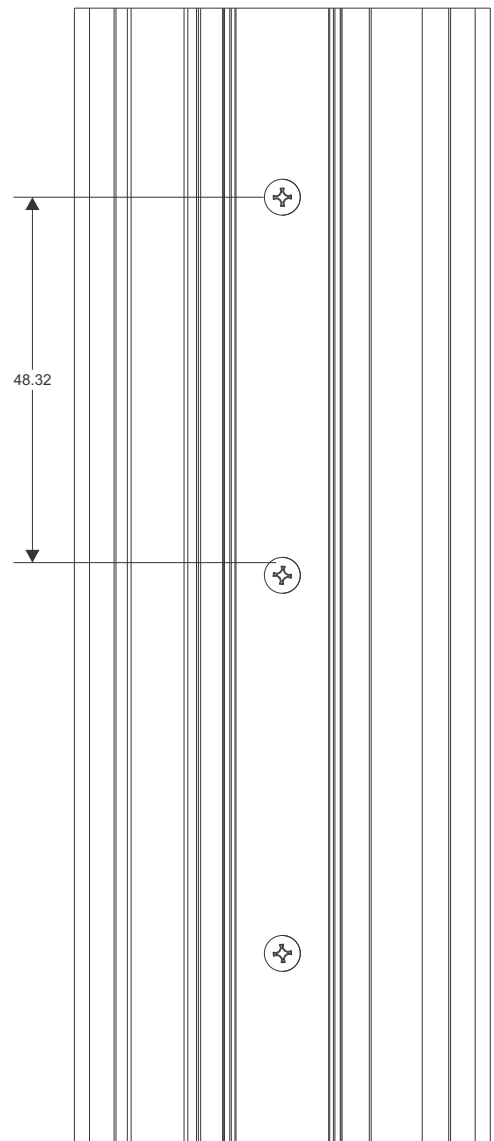
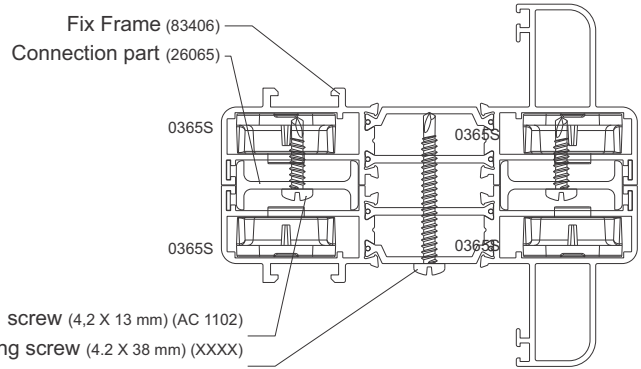
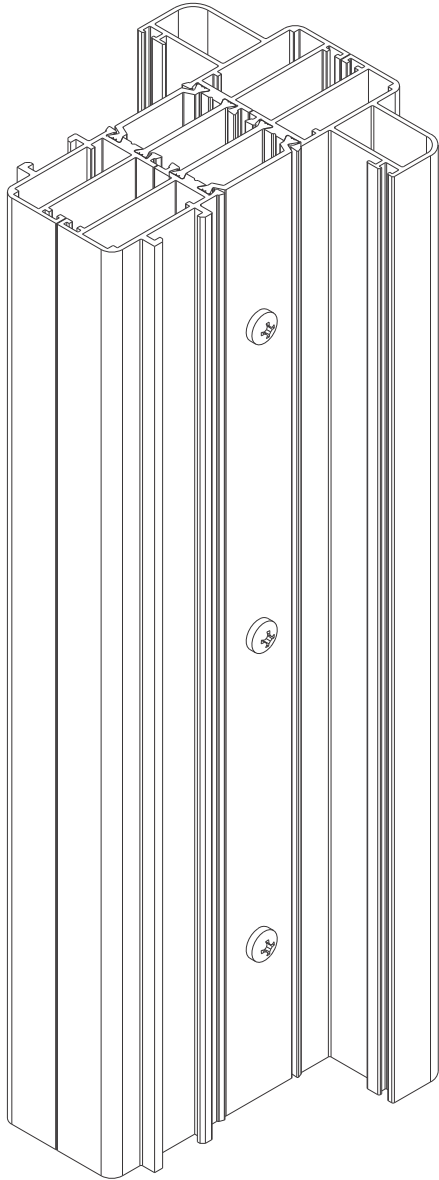

Scale: 1:2

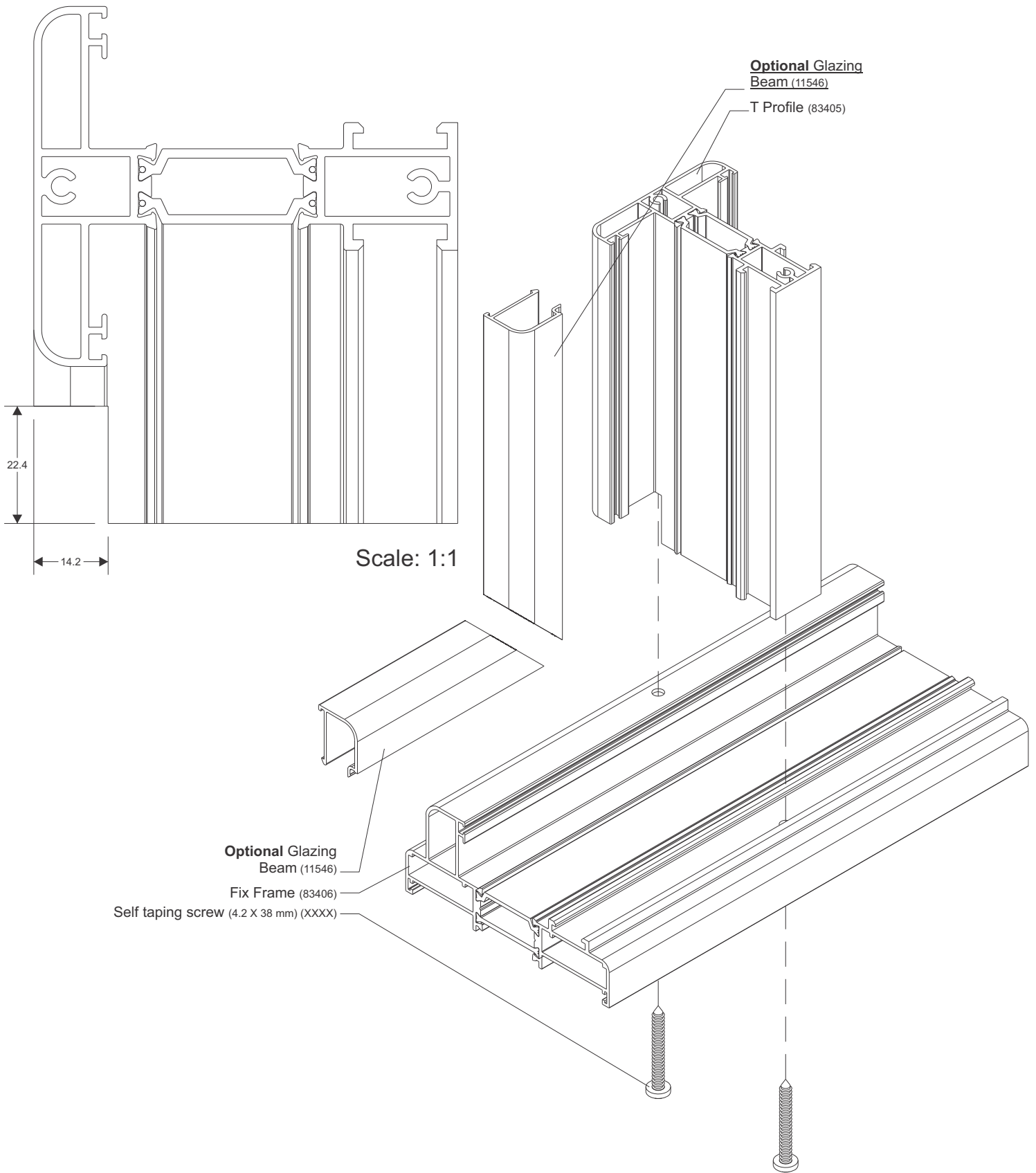

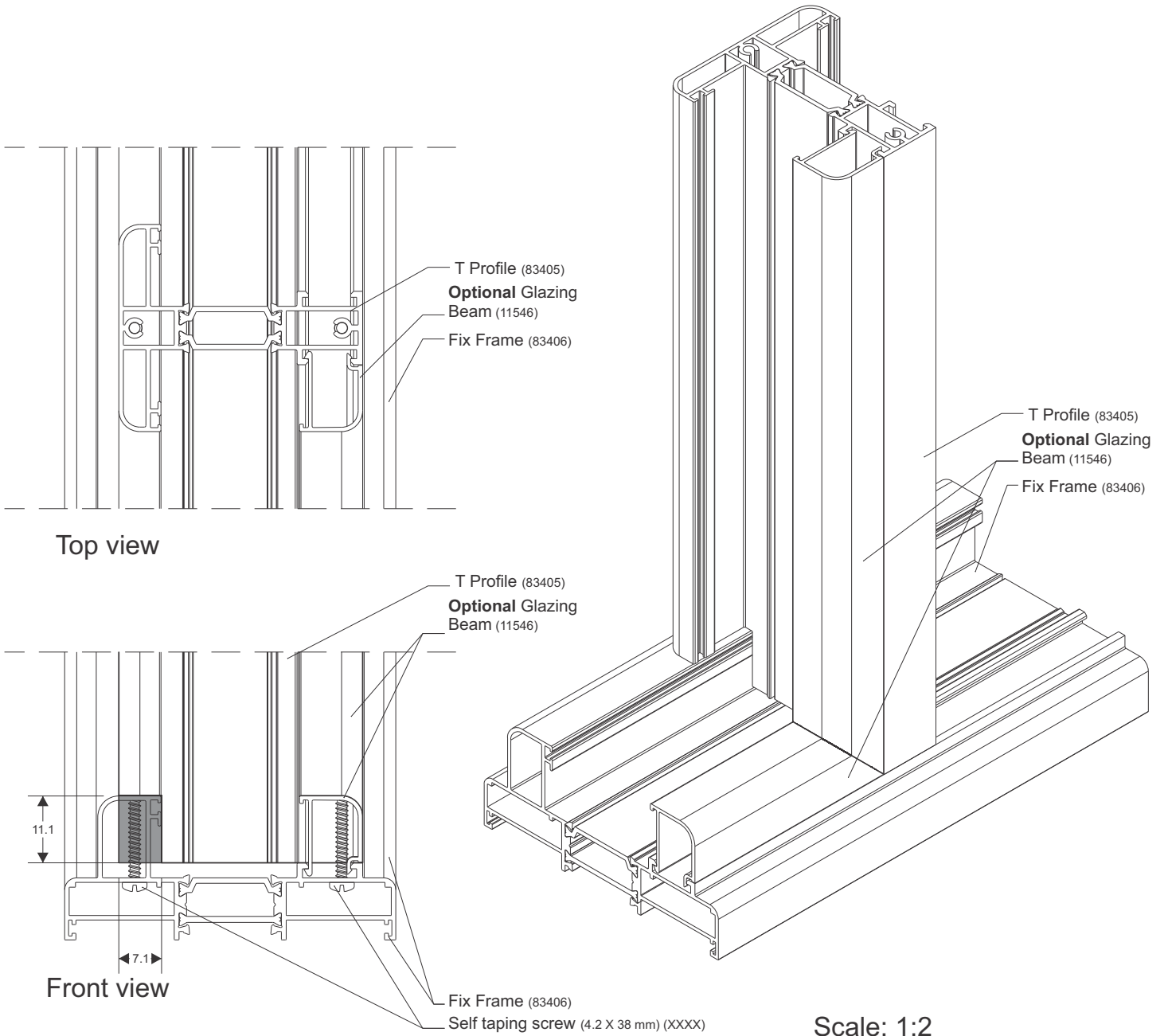

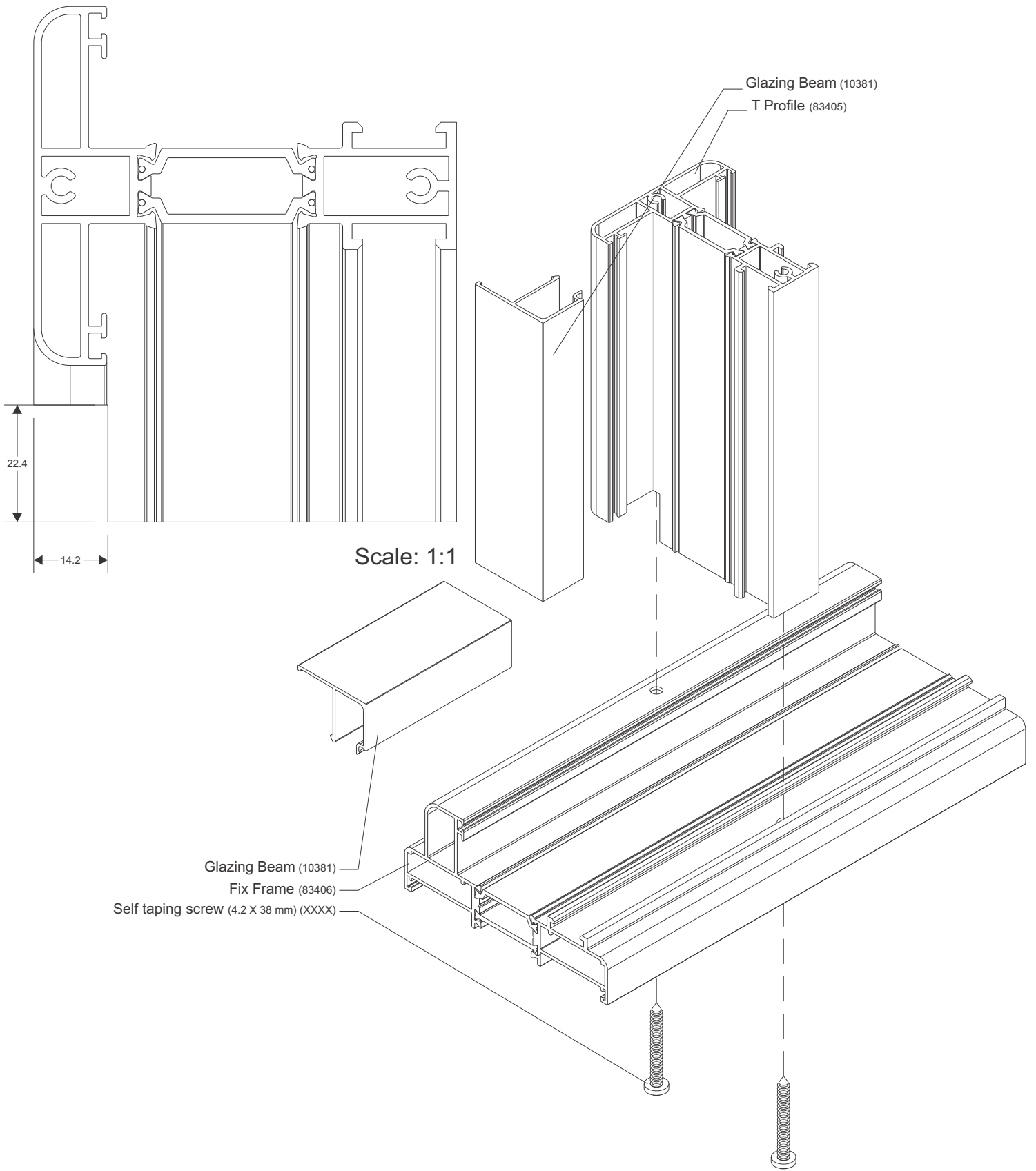

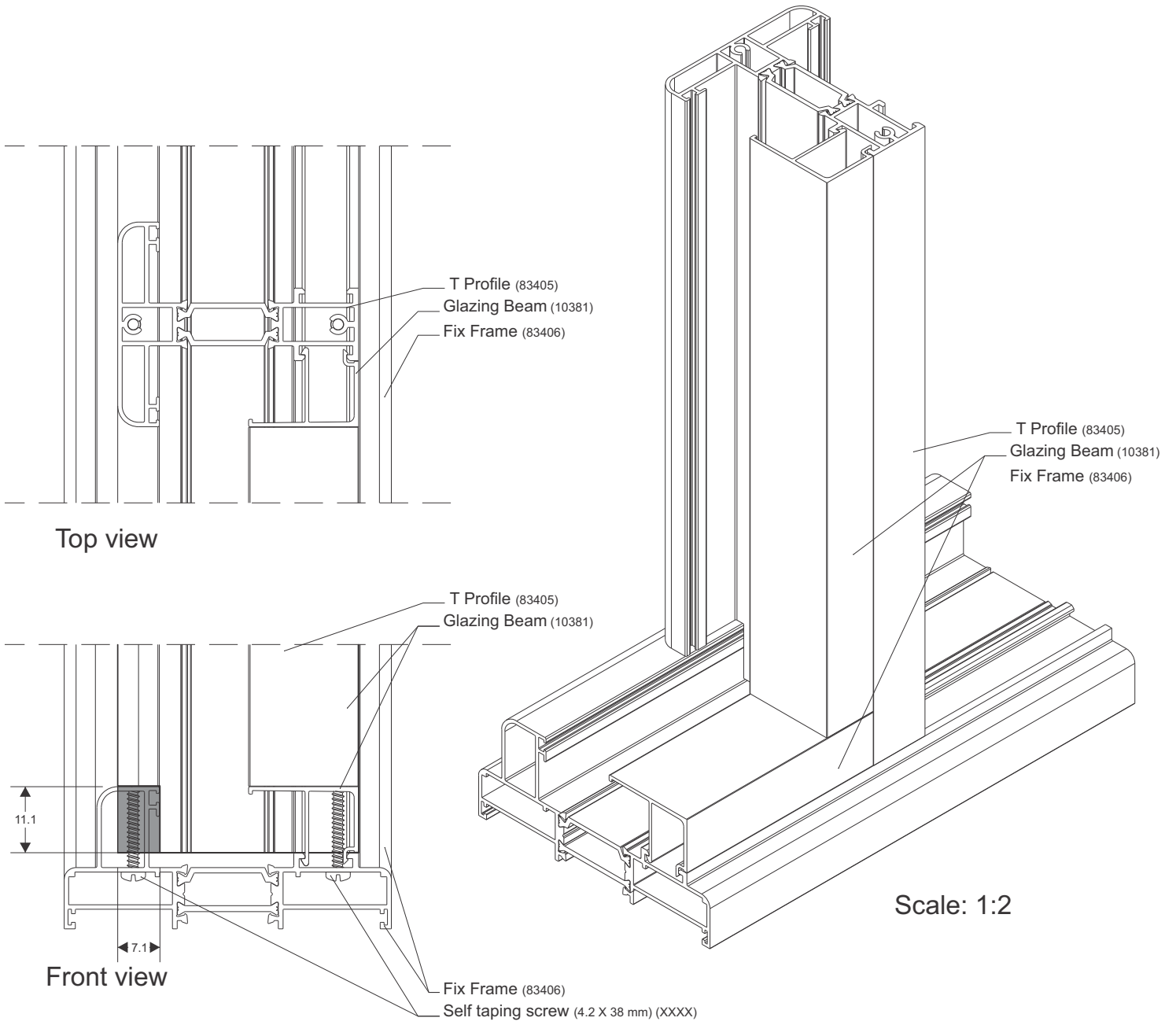

Explode View

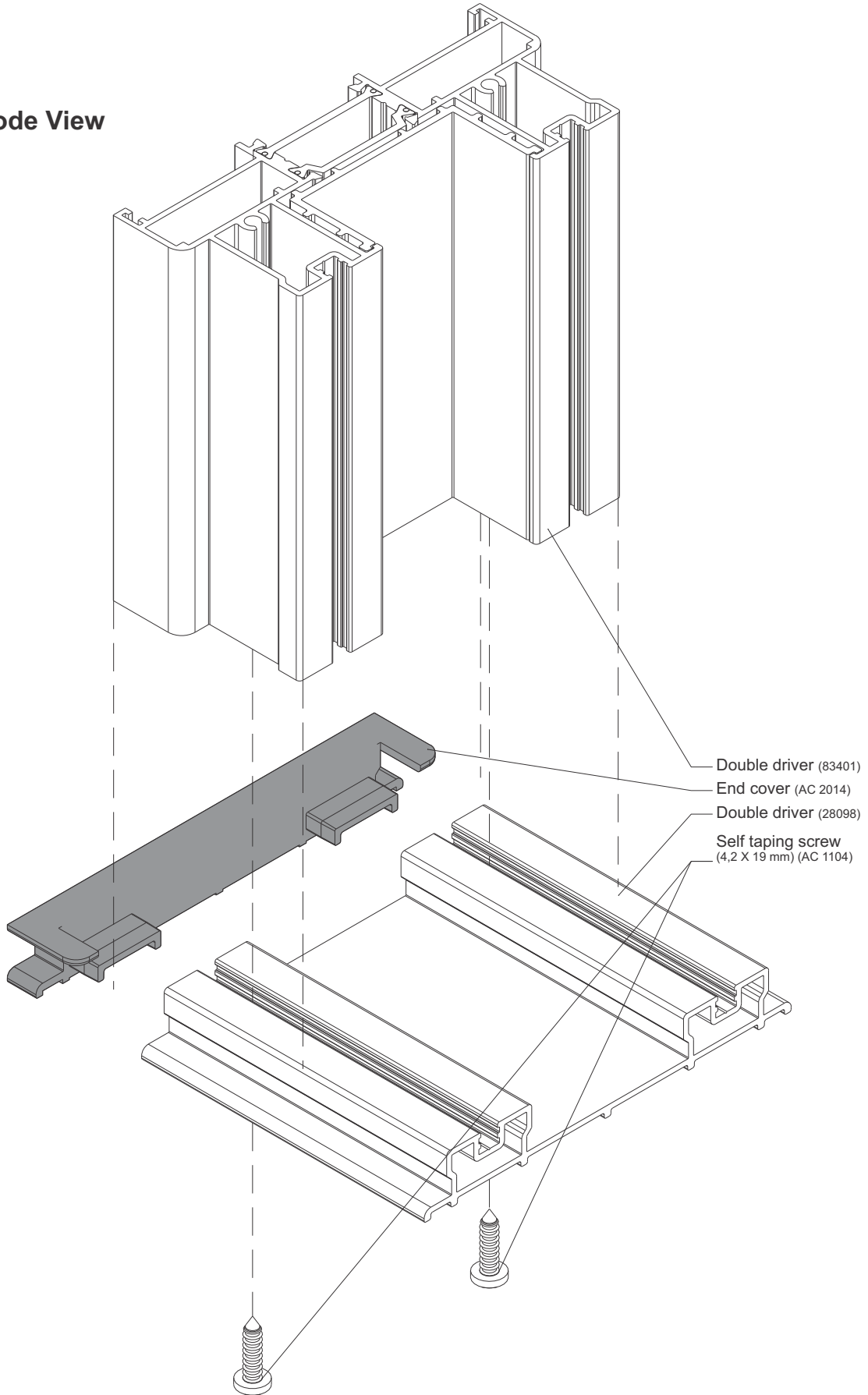

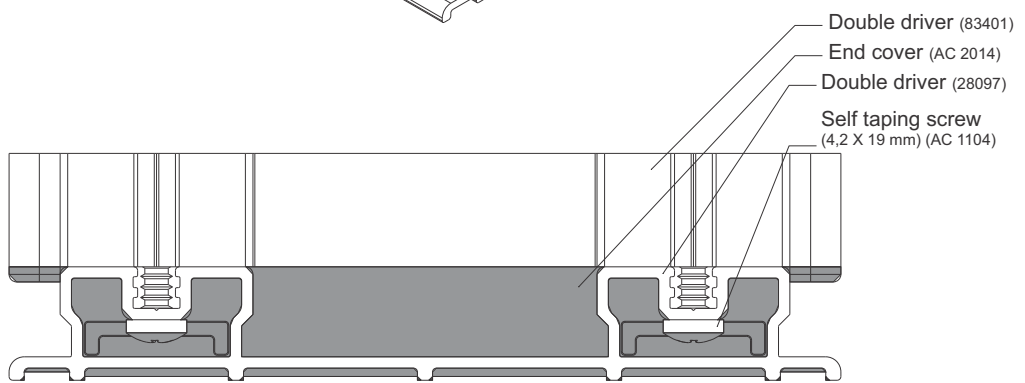
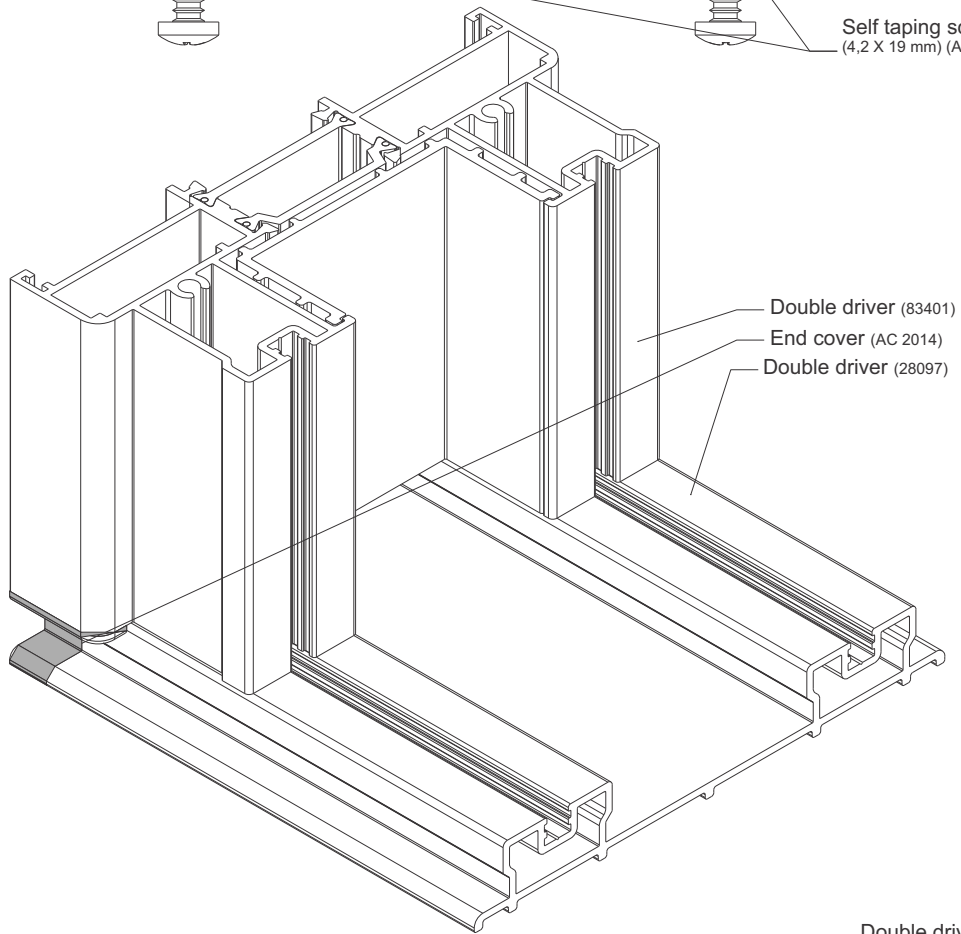
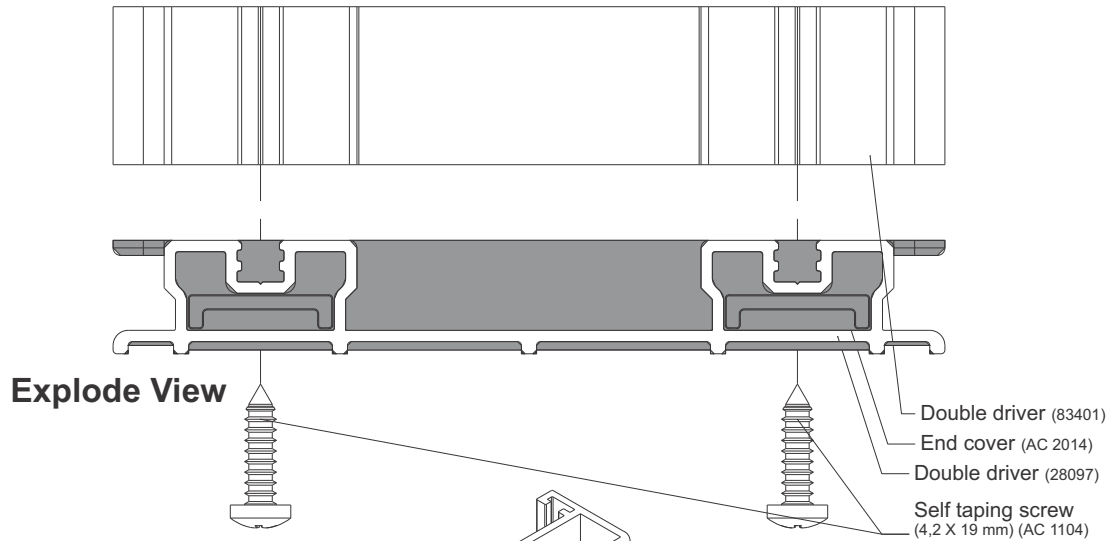

Explode View

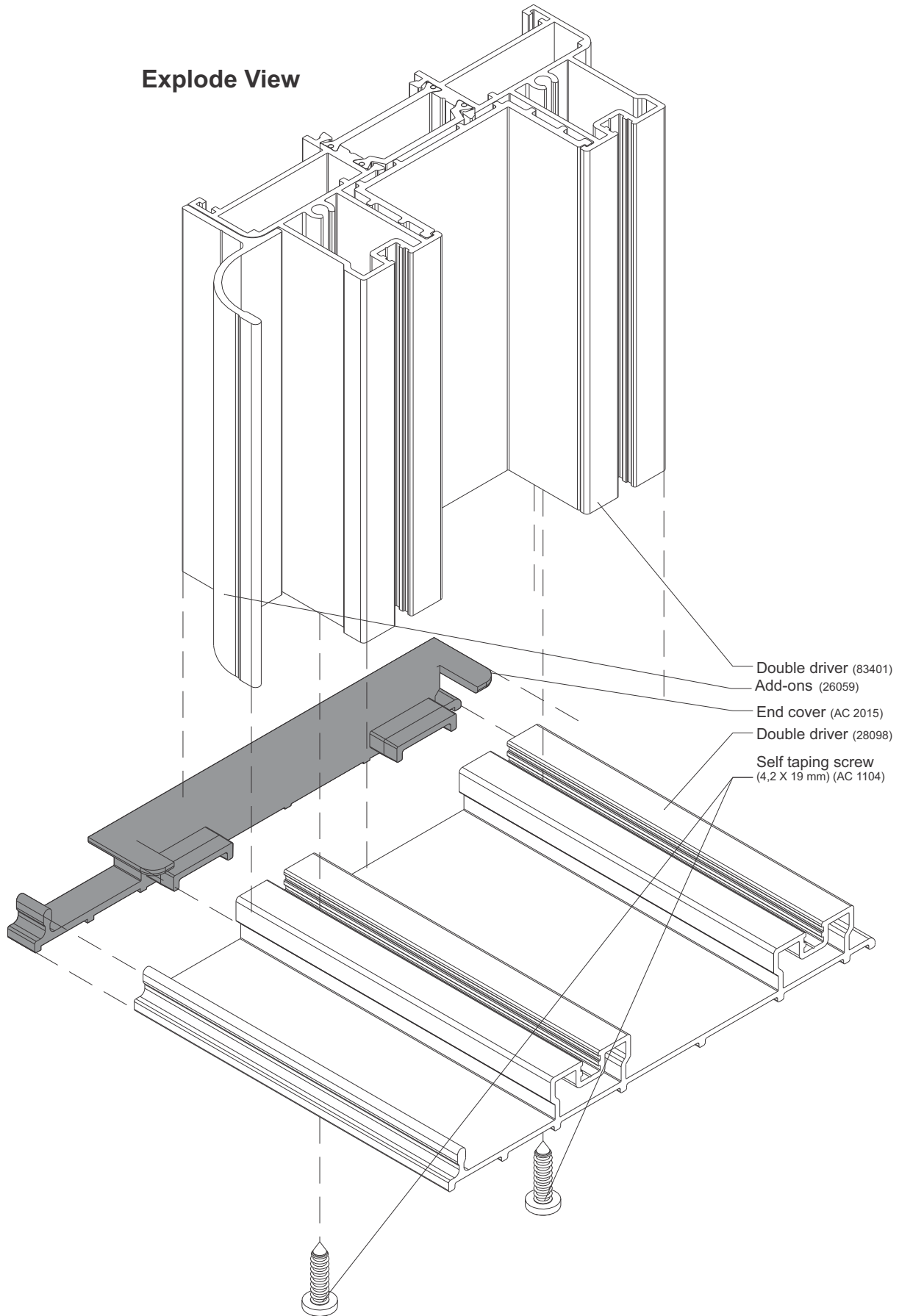

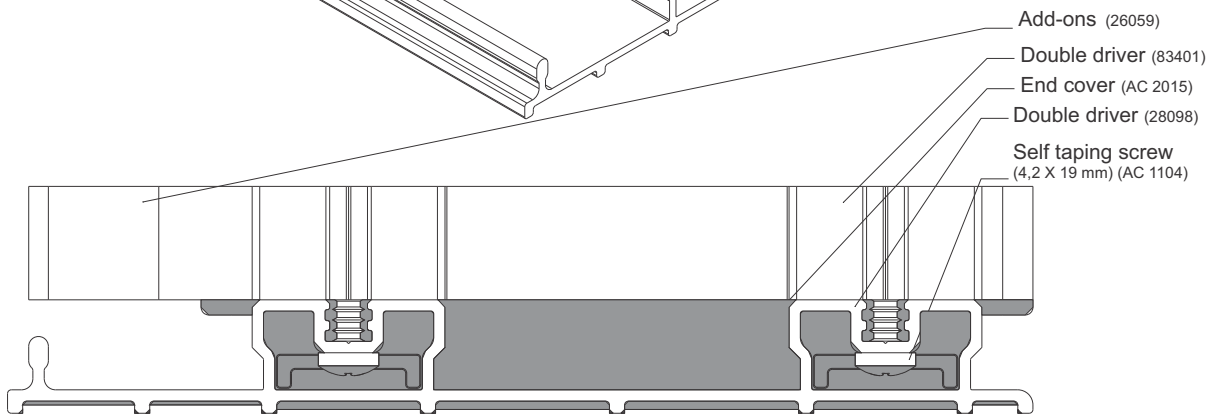
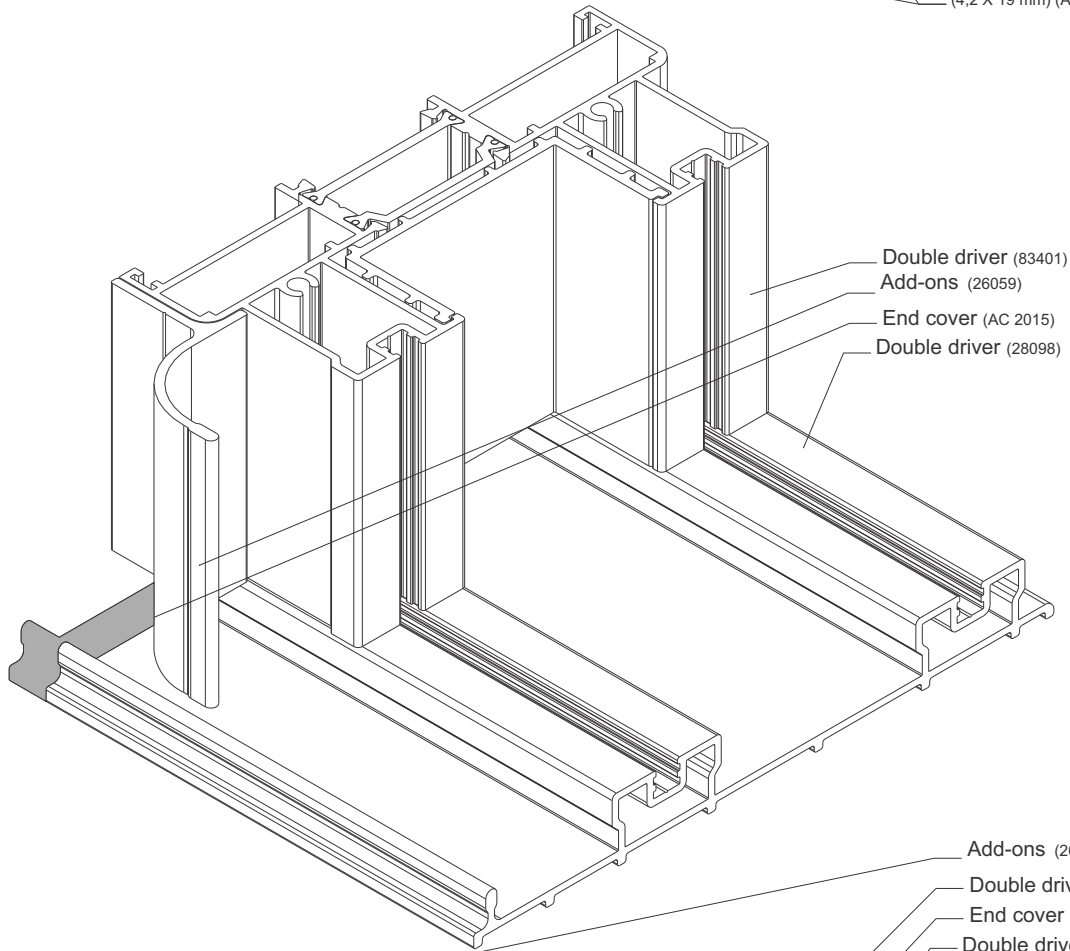
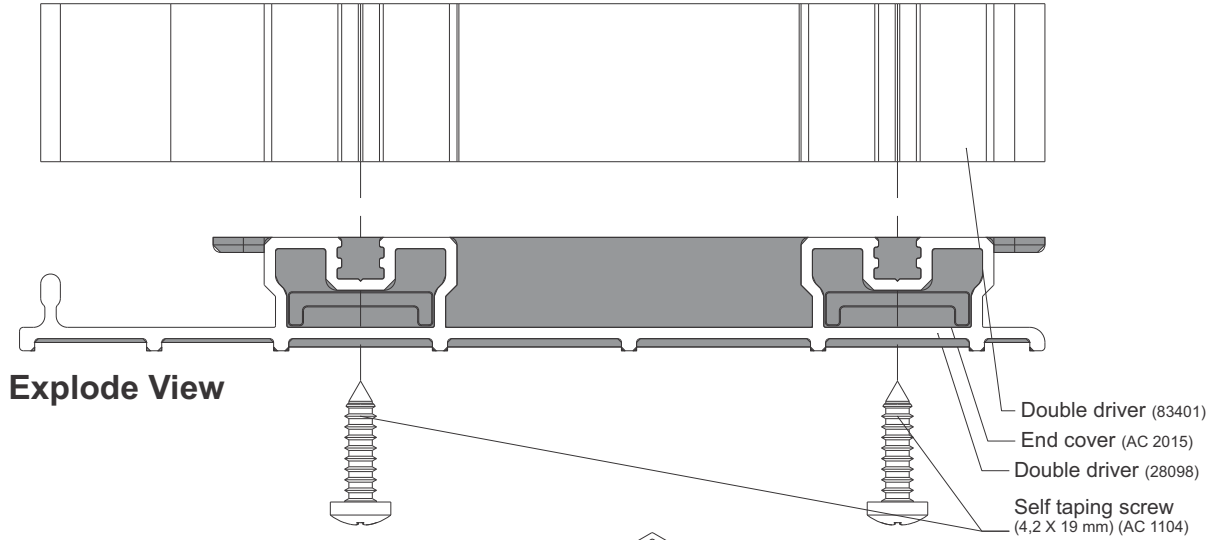

Front View

Explode View

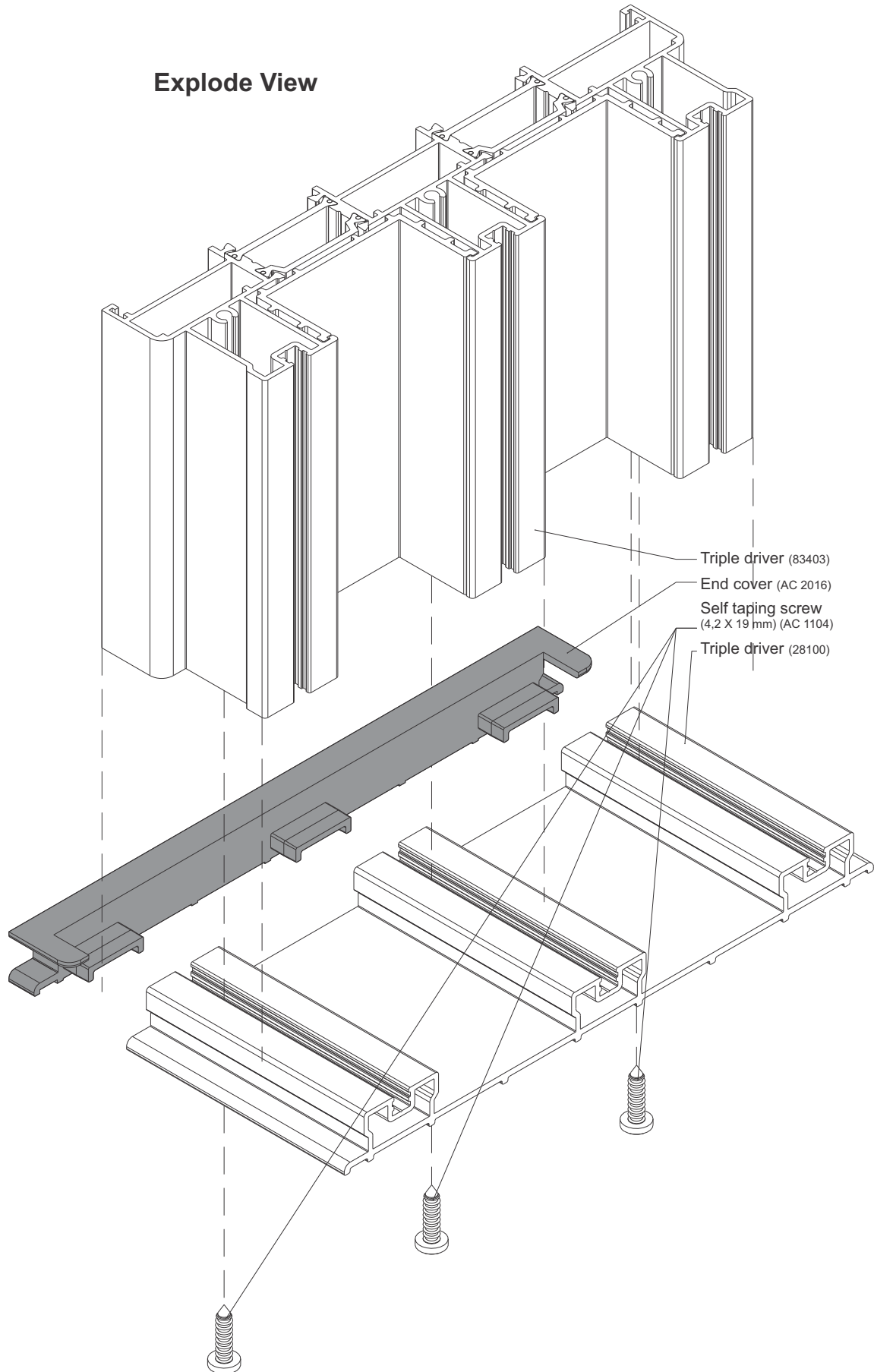

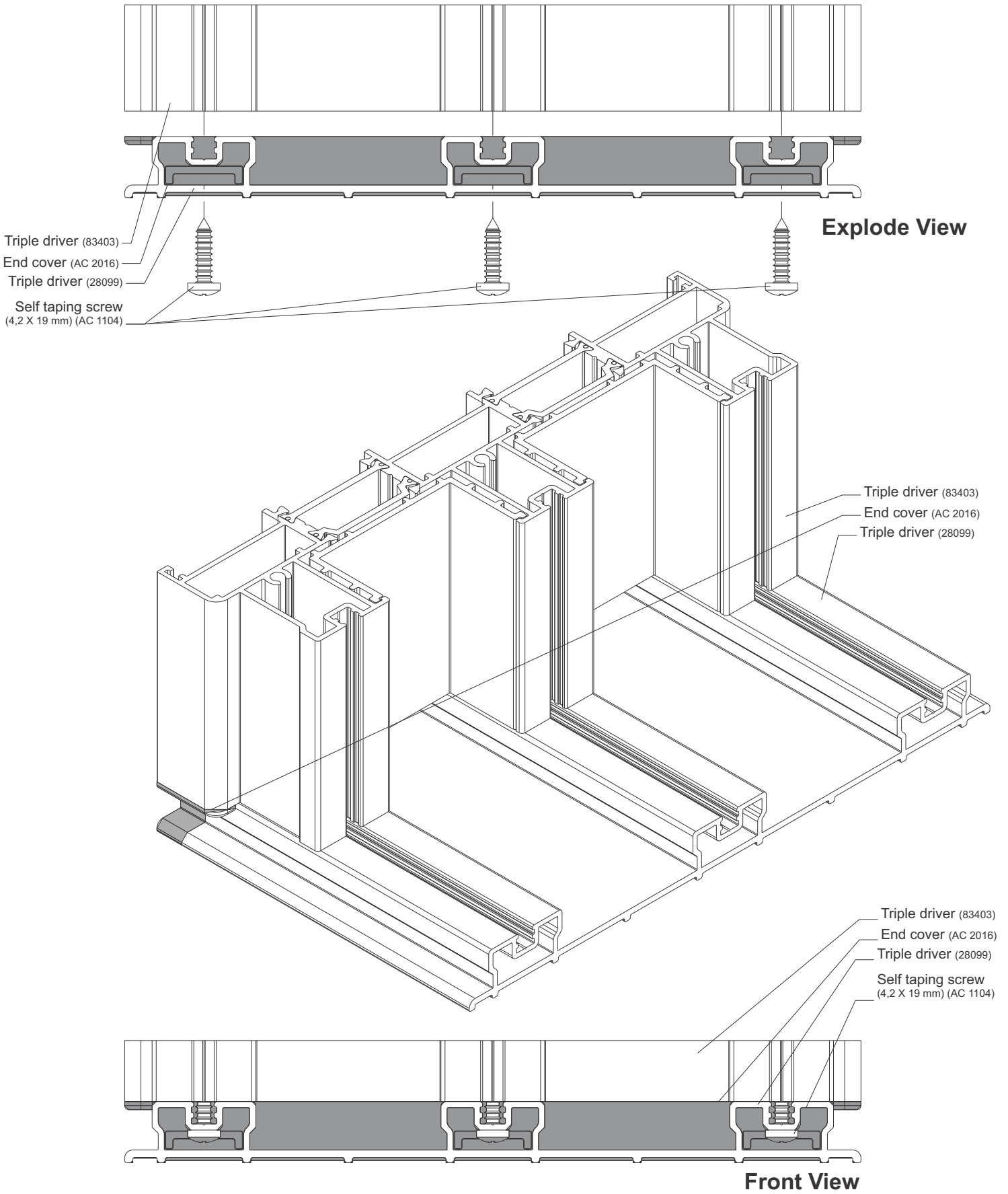

Explode View

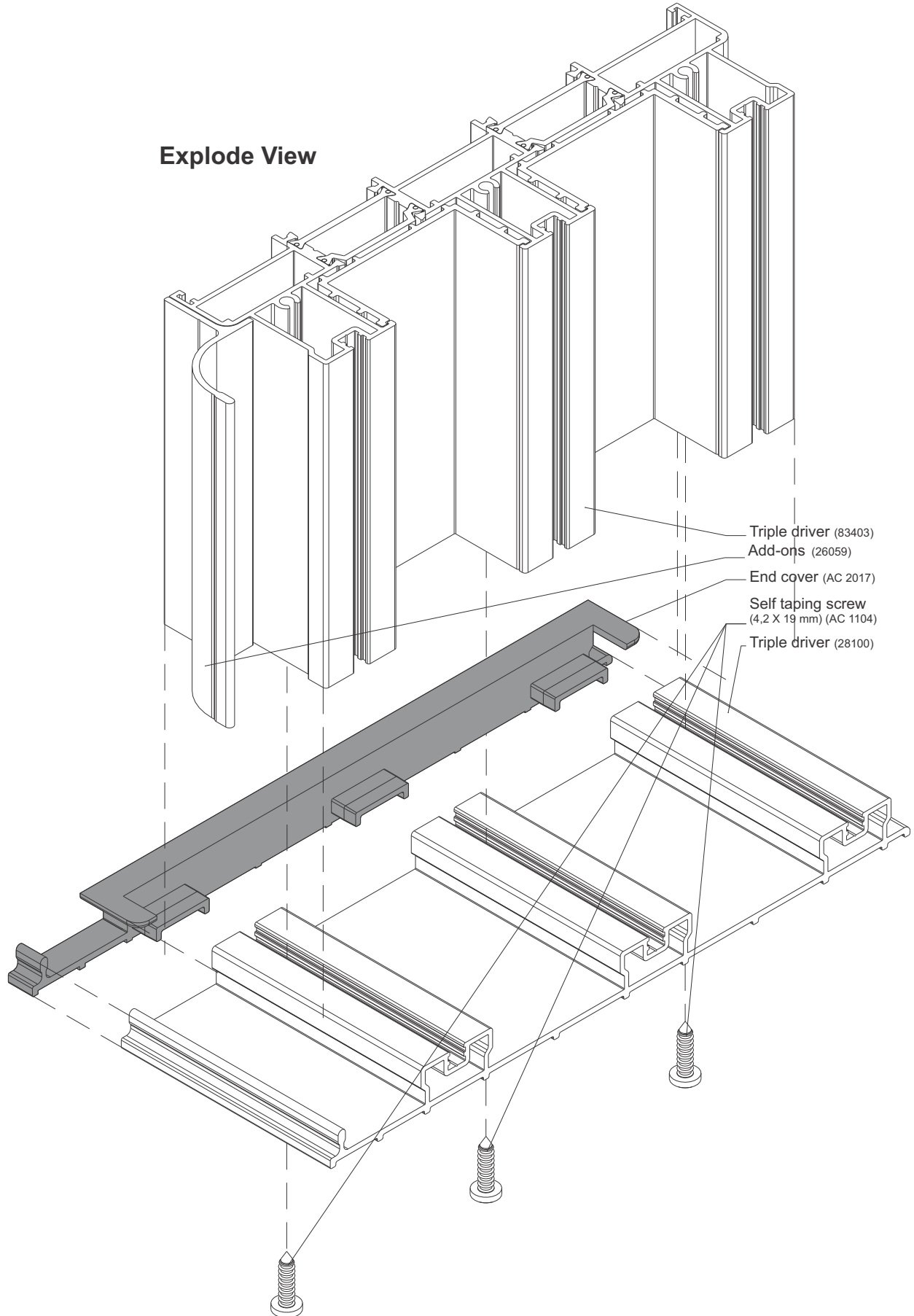

- Triple driver (83403)
- Add-ons (26059)
- End cover (AC 2017)
- Self tapping screw
(4,2 X 19 mm) (AC 1104)
- Triple driver (28100)

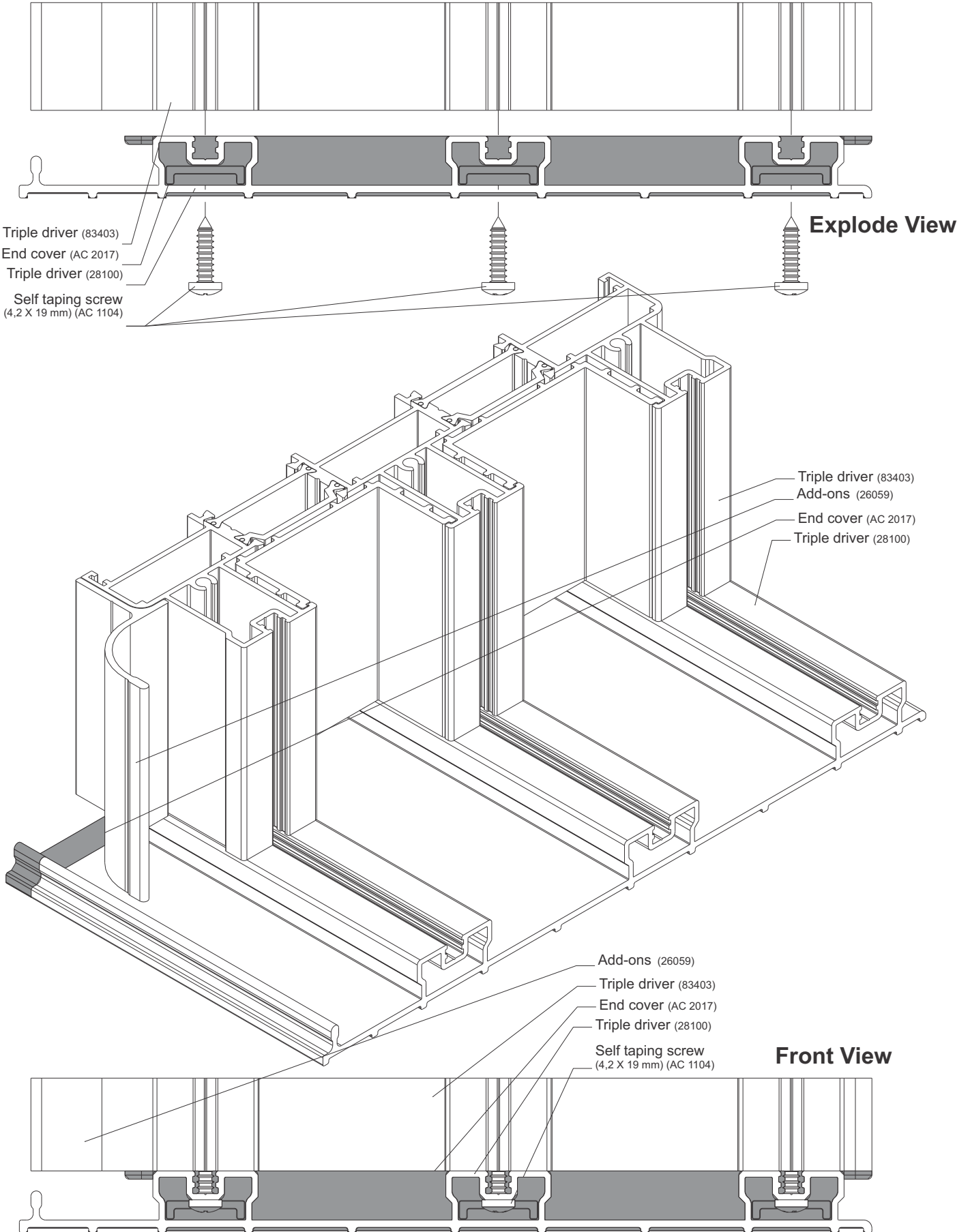

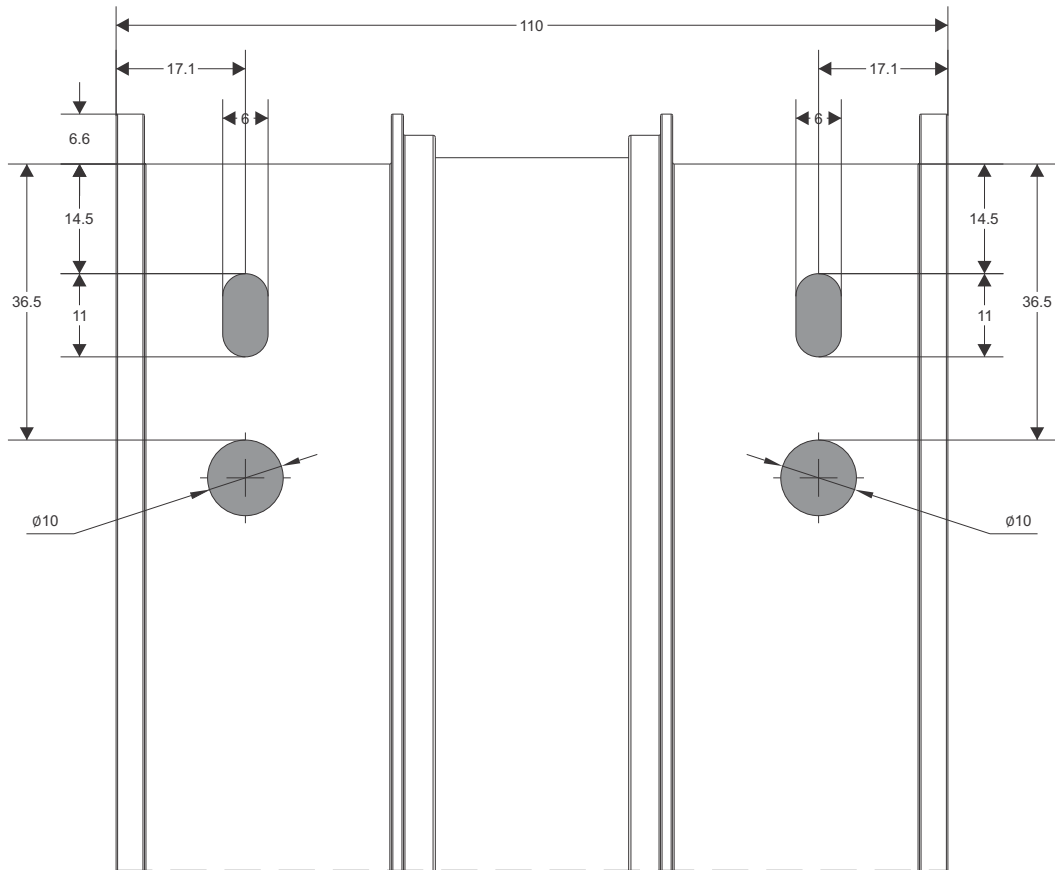
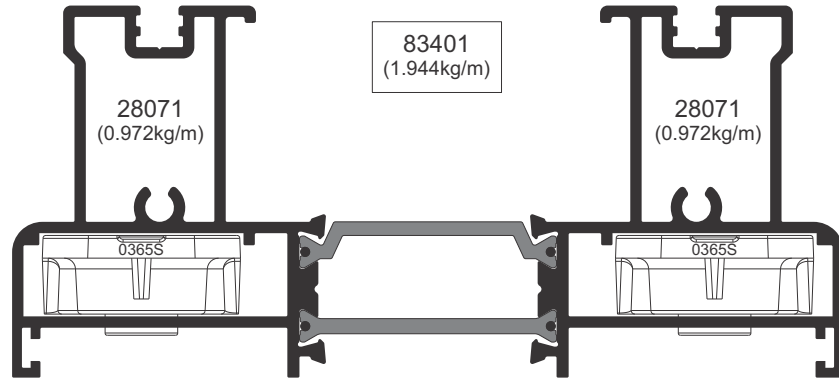

Scale: 1:1

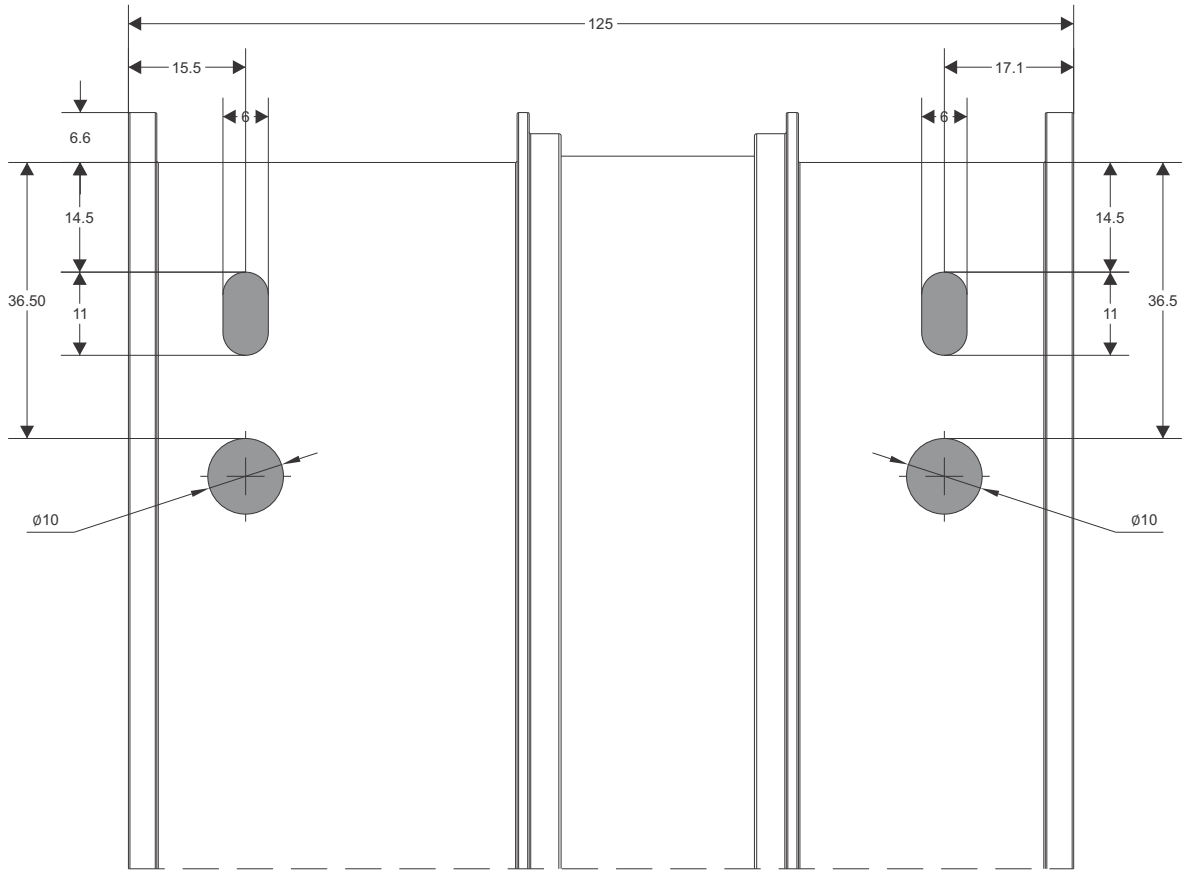
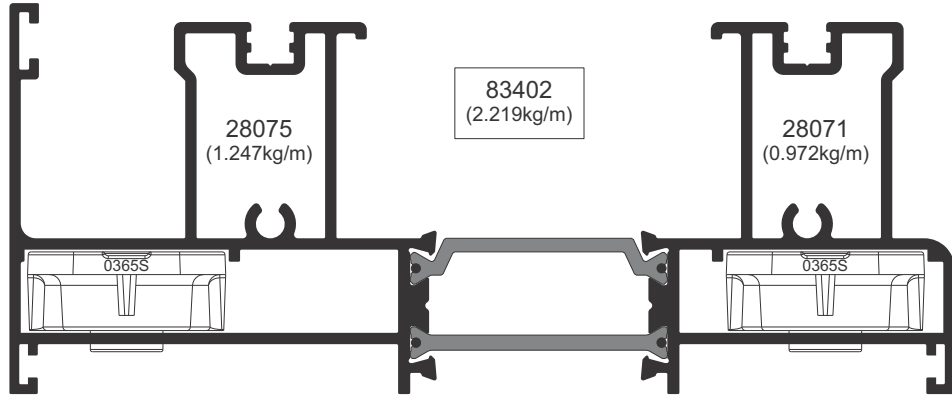

Scale: 1:1

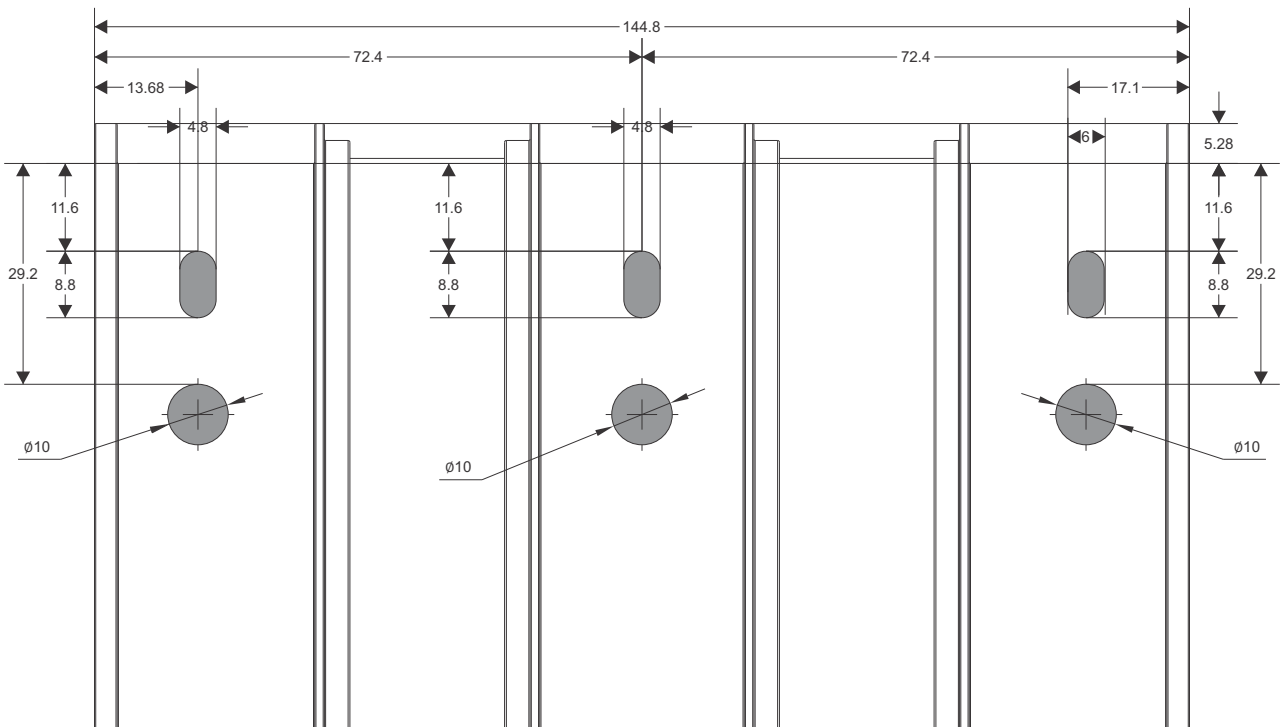
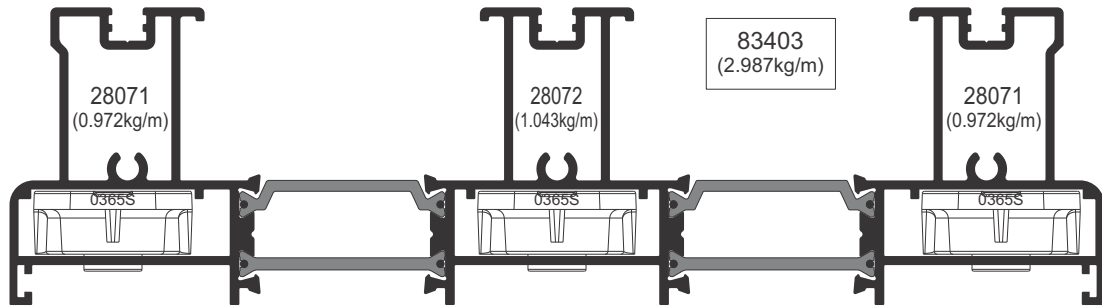

Scale: 0.8

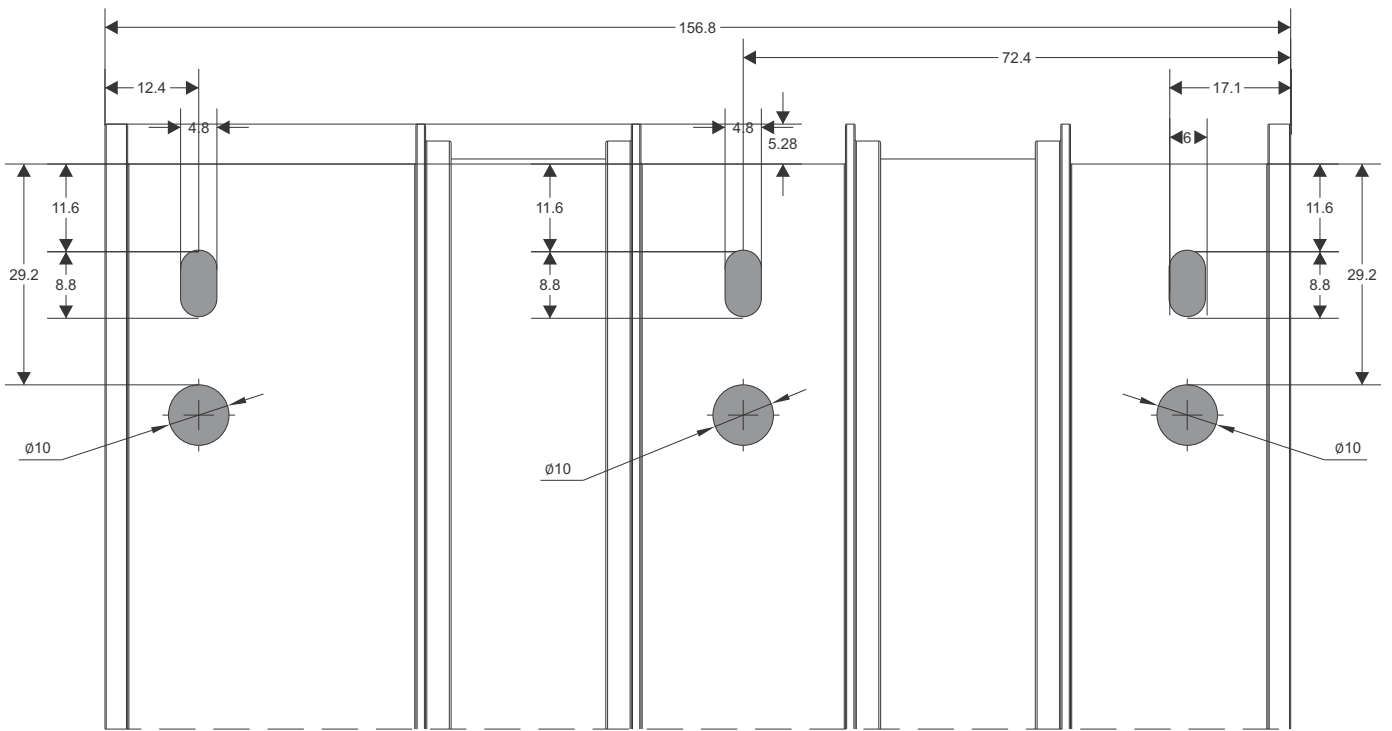
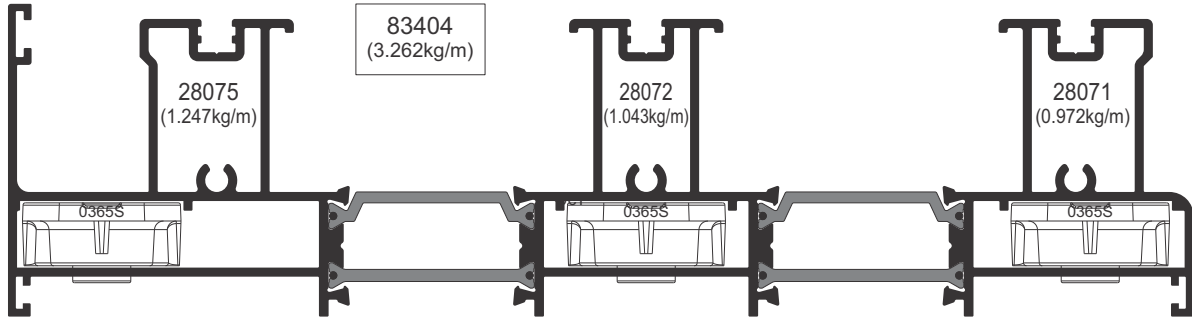

Scale: 0.8

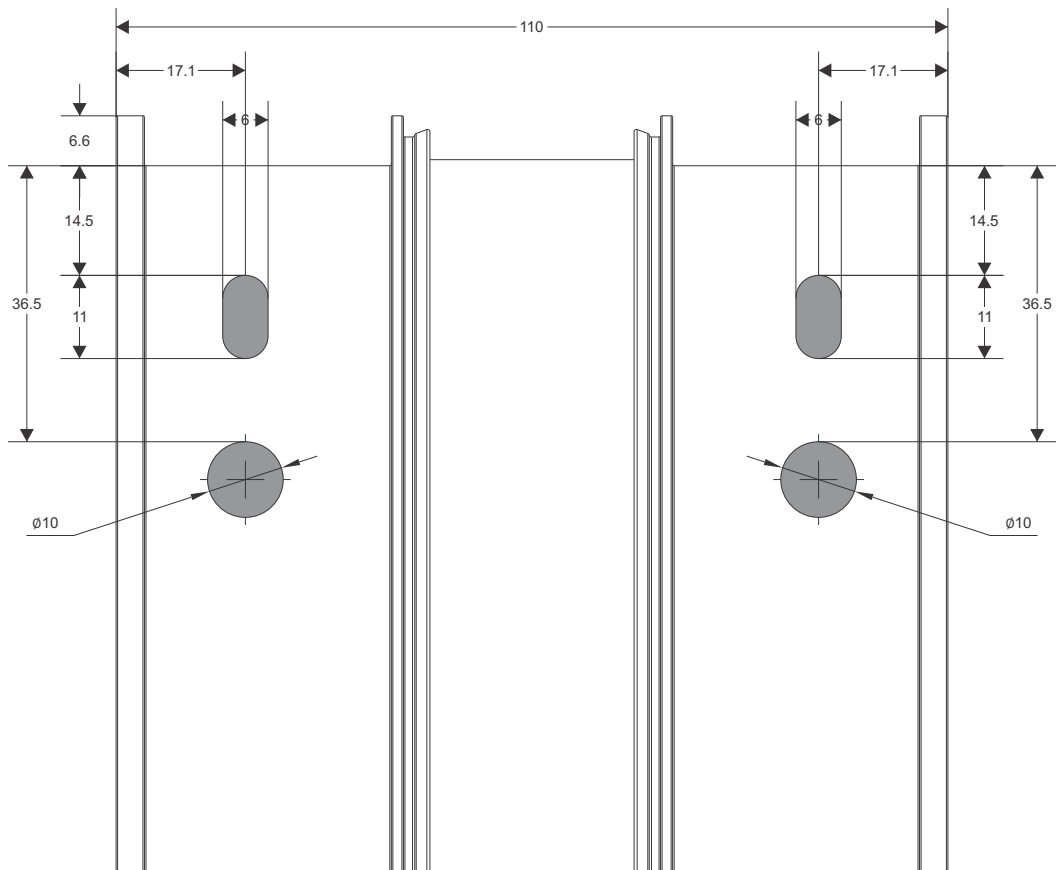
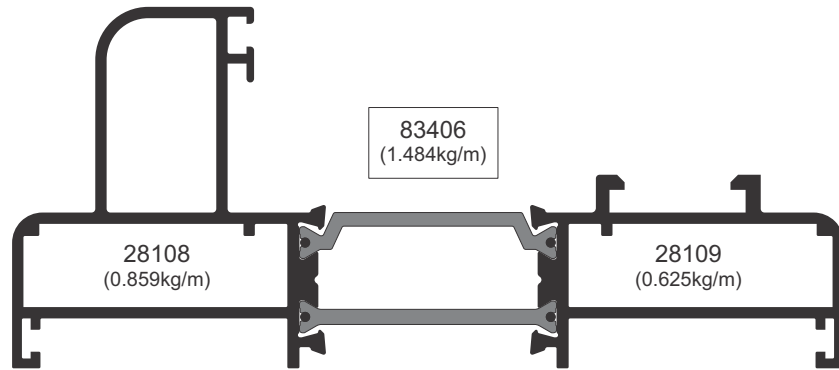

Scale: 1:1

New Sliding System
Water drainage Cover PLUS

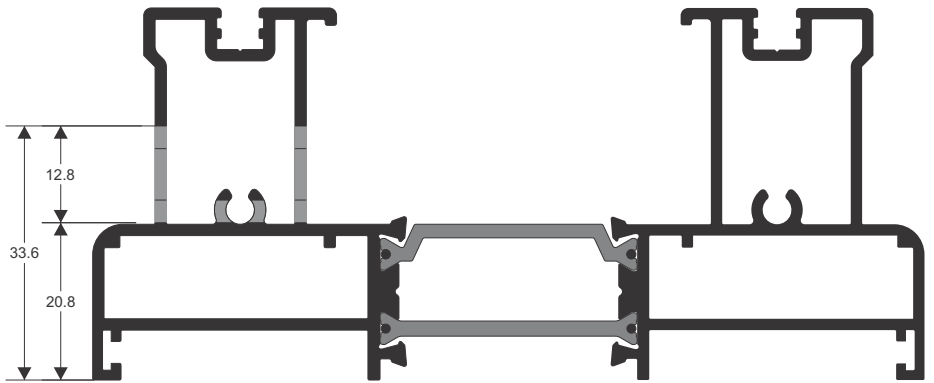
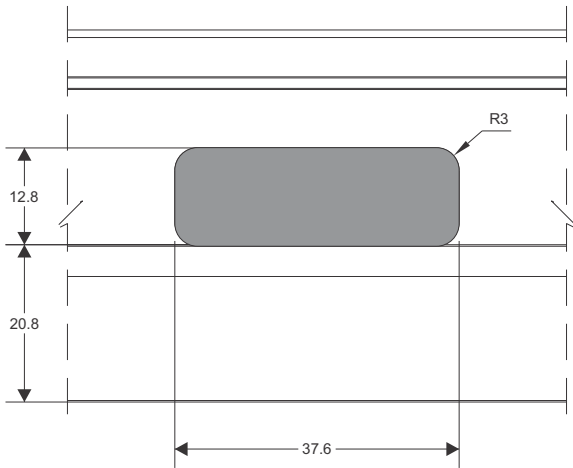
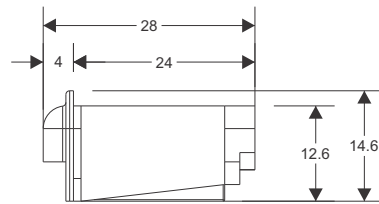
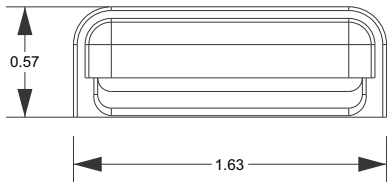
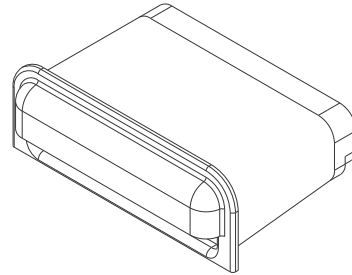
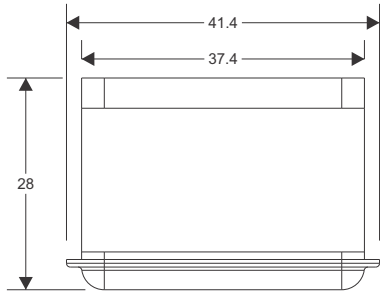

Double driver (83401)

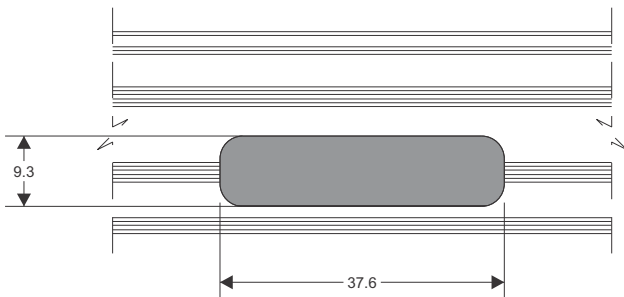

Frame Adapter (PVC 103)

New Sliding System
Water drainage Cover PLUS

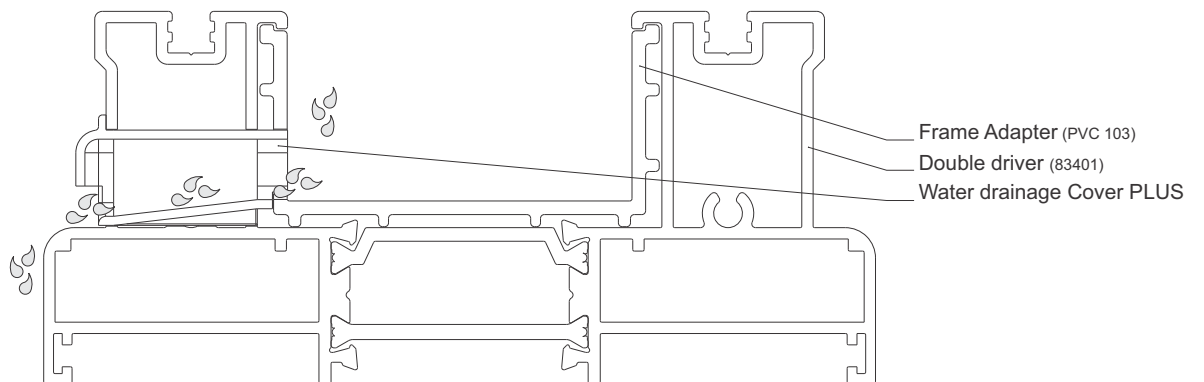
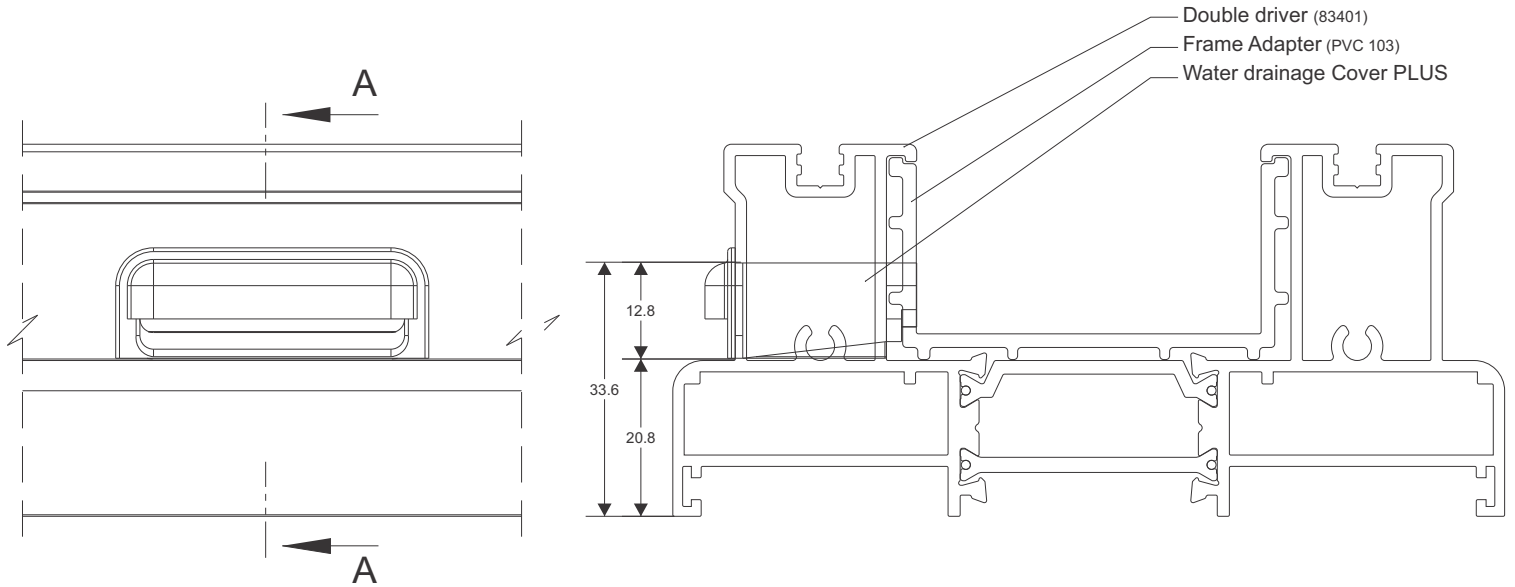

Handwriting practice area with 20 horizontal dashed lines.

STATIC LOADS CALCULATION

New sliding graphs 20170911

Static loads Calculation

83211 + 26030

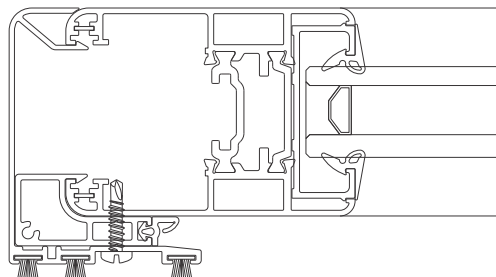
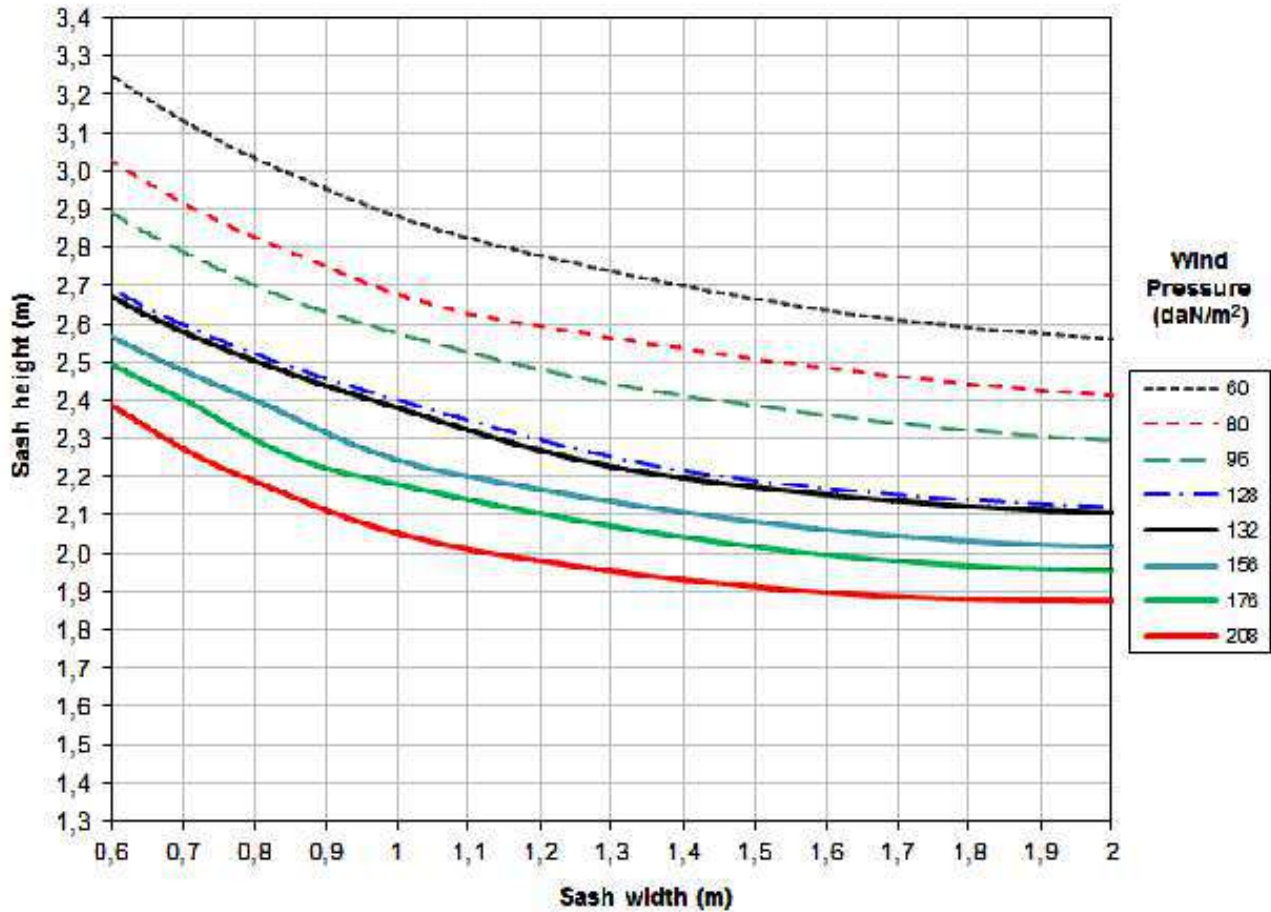

New sliding graphs 20170911

Static loads Calculation

83211 + 26030 + 26040

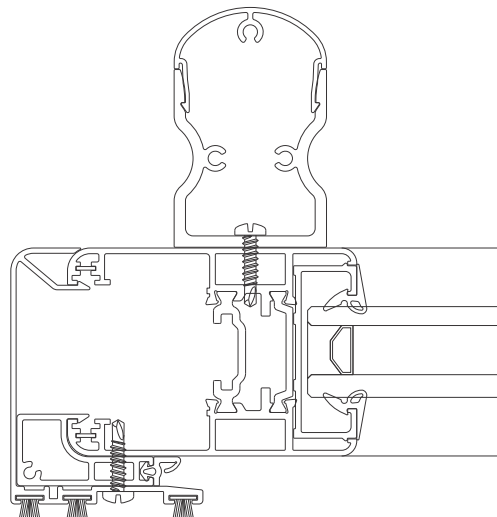
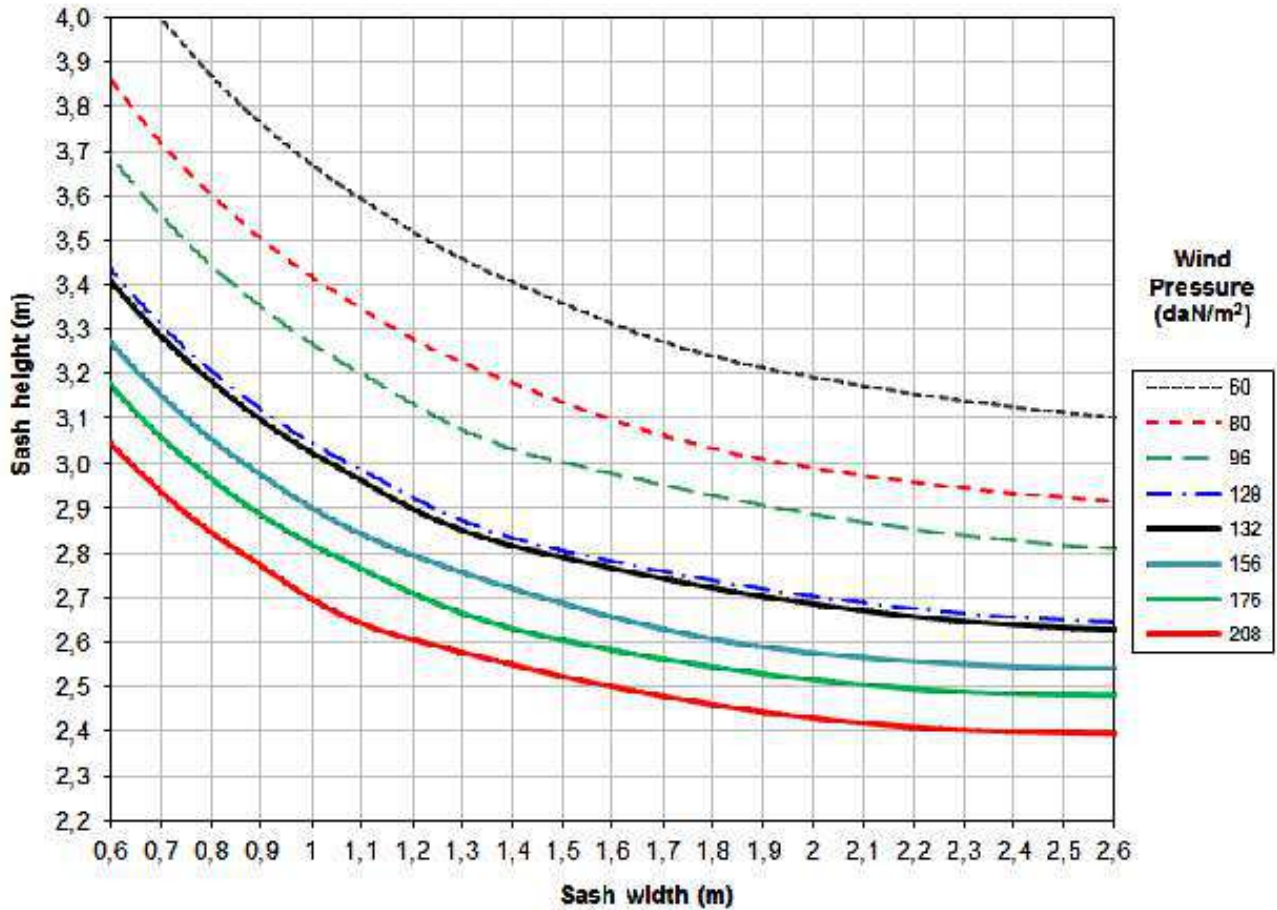

New sliding graphs 20170911

Static loads Calculation

83211 (x2) + 26030 + 26040

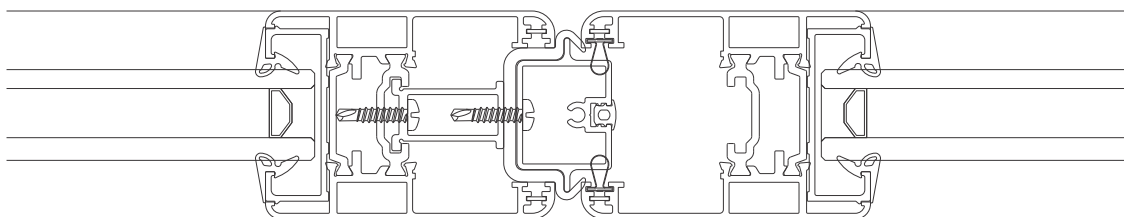
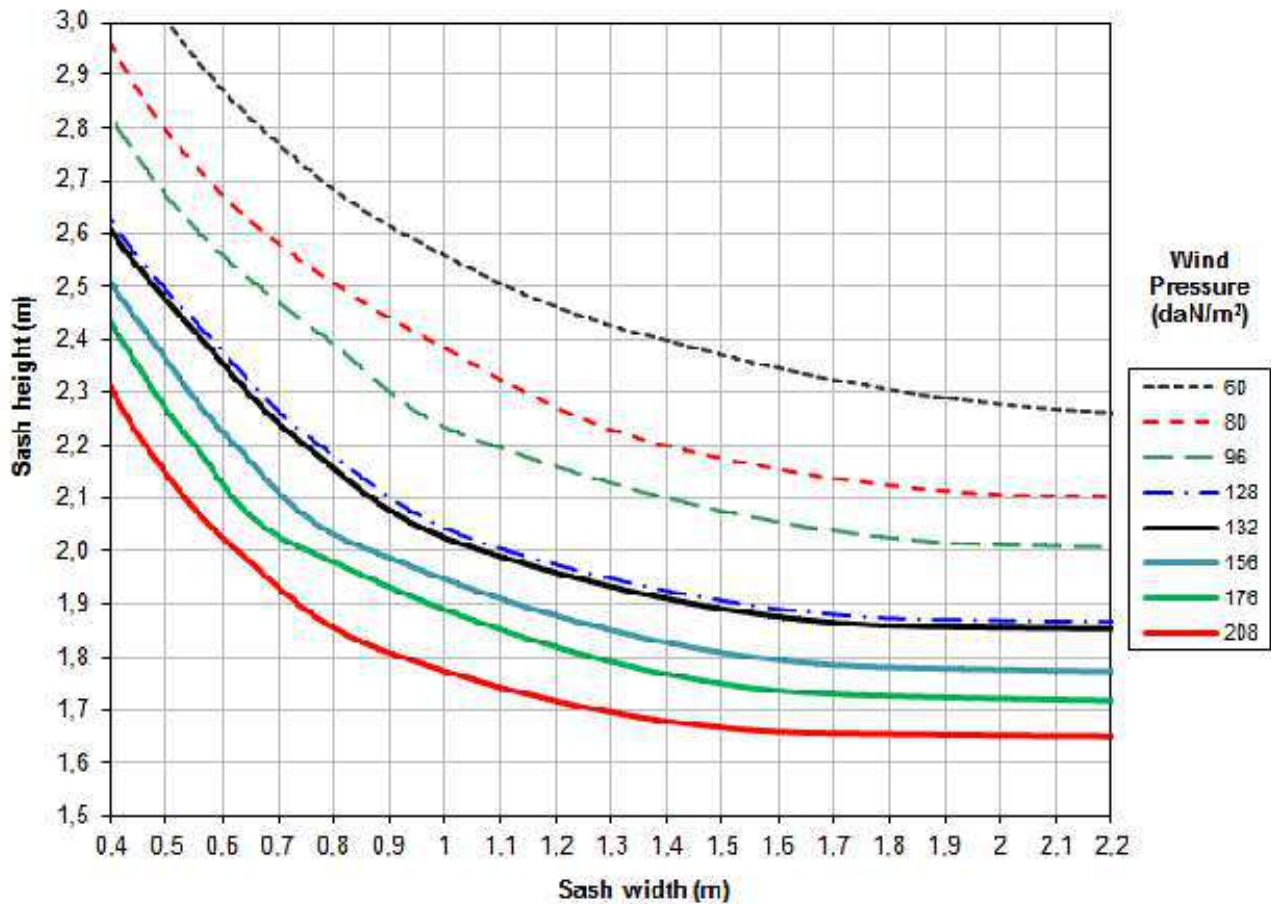



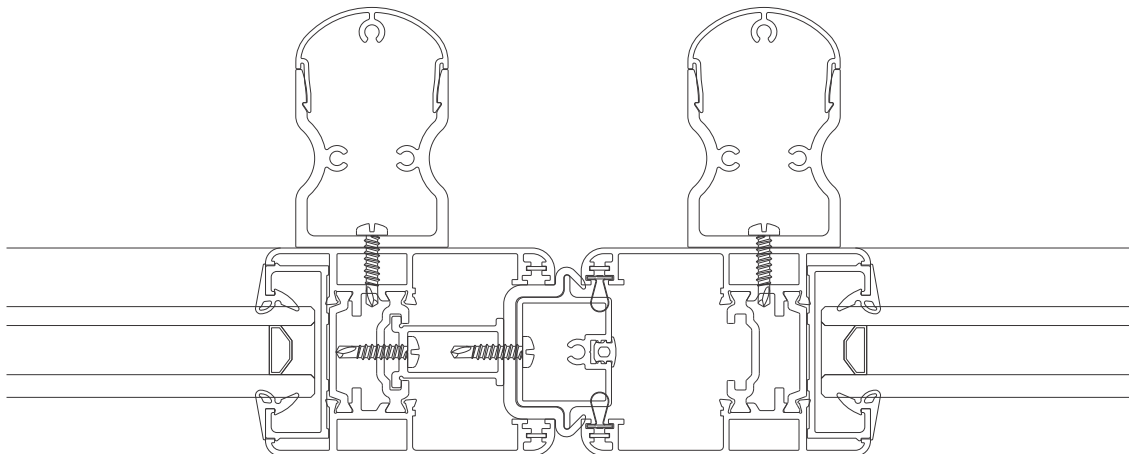
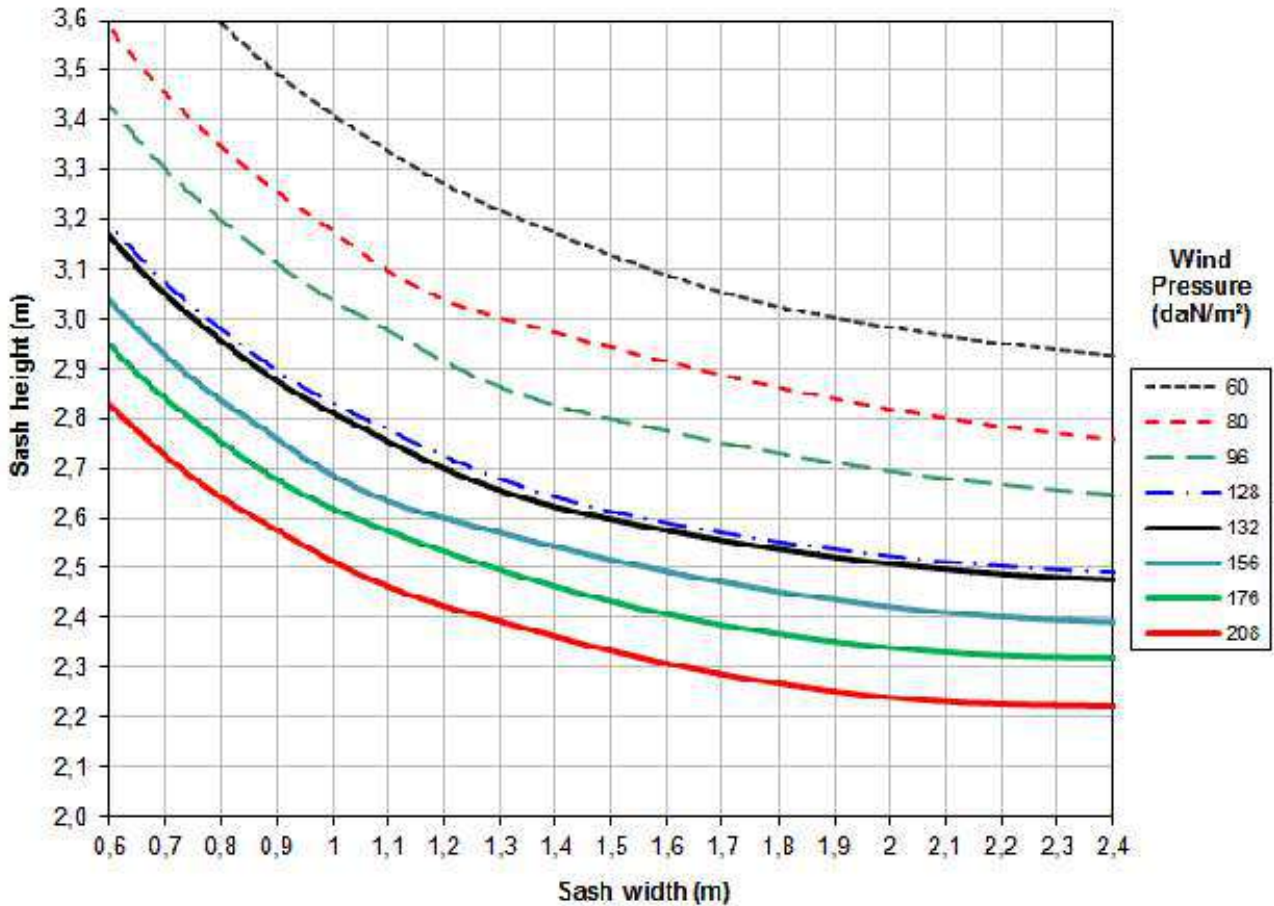

Static loads Calculation





83211(x2) + 26040(x2) + 28094 + 28095



Handwriting practice area with 20 horizontal dashed lines.

CUTTING TABLE

| Cutting table | | | |
|-------------------------------------|-------|---|--------------------------------------|
| Profile Name | Code | Symbol | Quantity / Cutting |
| Double driver | 83401 |  | 2 $\triangle Fw$ |
| | | | 2 $\triangle Fh$ |
| Sash | 83211 |  | 4 $\triangle Sw = \frac{Fw-20,9}{2}$ |
| | | | 4 $\triangle Sh = Fh-82,4$ |
| Interlock | 26030 |  | 2 $\square INh = Sh - 6$ |
| Add-on Profile (Fly screen rail) | 26059 |  | 2 $\triangle AD1w = Fw$ |
| | | | 2 $\triangle AD1h = Fh$ |
| Add-on Profile (Wall cover) | 26060 |  | 2 $\triangle AD2w = Fw+47,6$ |
| | | | 2 $\triangle AD2h = Fh+47,6$ |

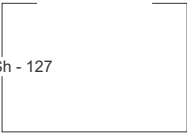
| Profile Name | Code | Symbol | Quantity / Cutting |
|--------------|-------|---|----------------------------|
| Fly screen | 28101 |  | 2 $\triangle FLw = Sw+15$ |
| | | | 2 $\triangle FLh = Sh$ |
| Handle | 26040 |  | 1 $\square HAh = Sh - 159$ |
| Handle cover | 26041 |  | 1 $\square HCh = Sh - 159$ |
| Rail guide | 26029 |  | 2 $\square Rw = Fw - 90$ |
| Glazing | - |  | 2 $\square Gh = Sh - 127$ |

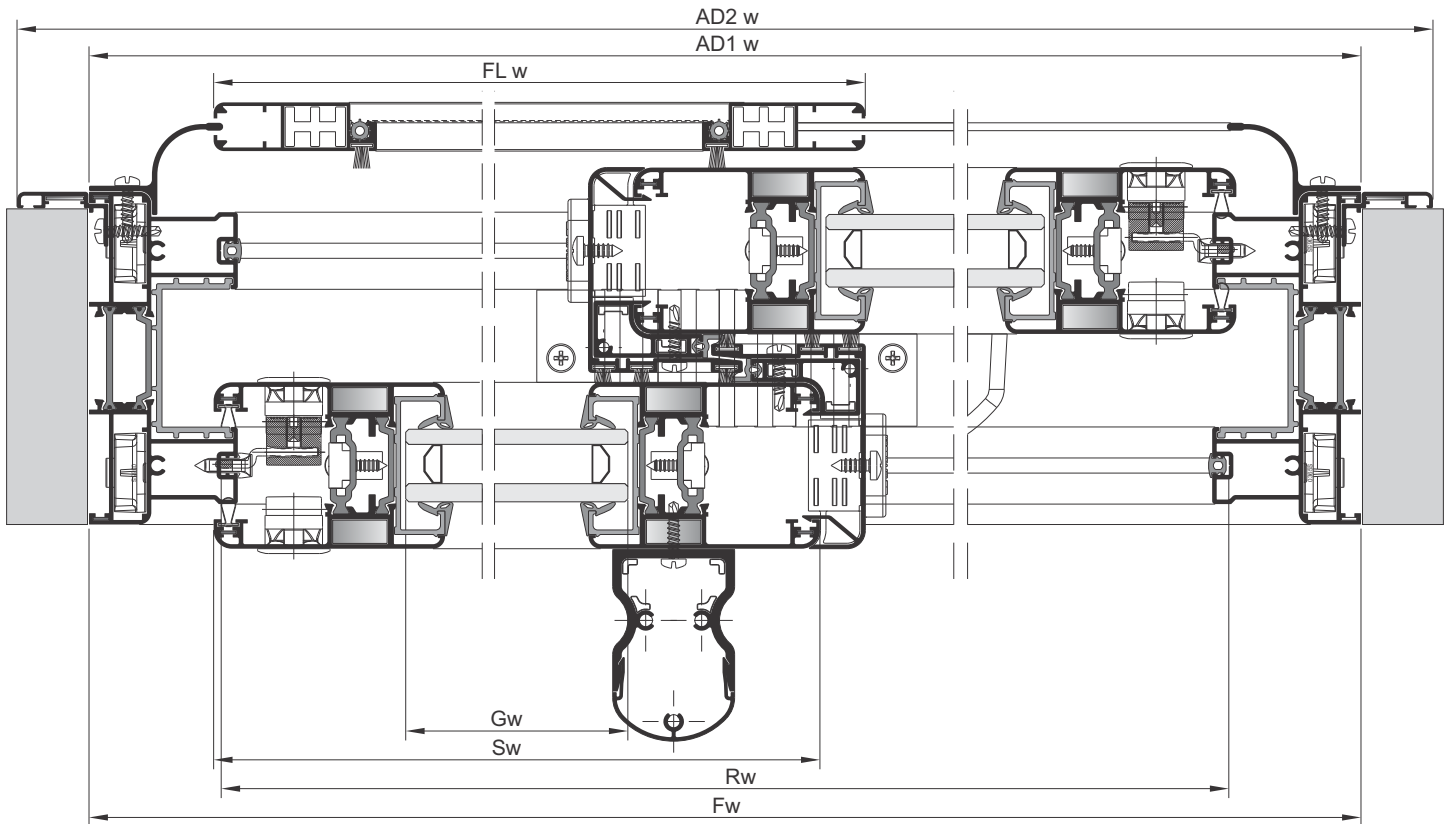

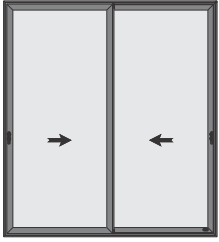

Cutting Angles

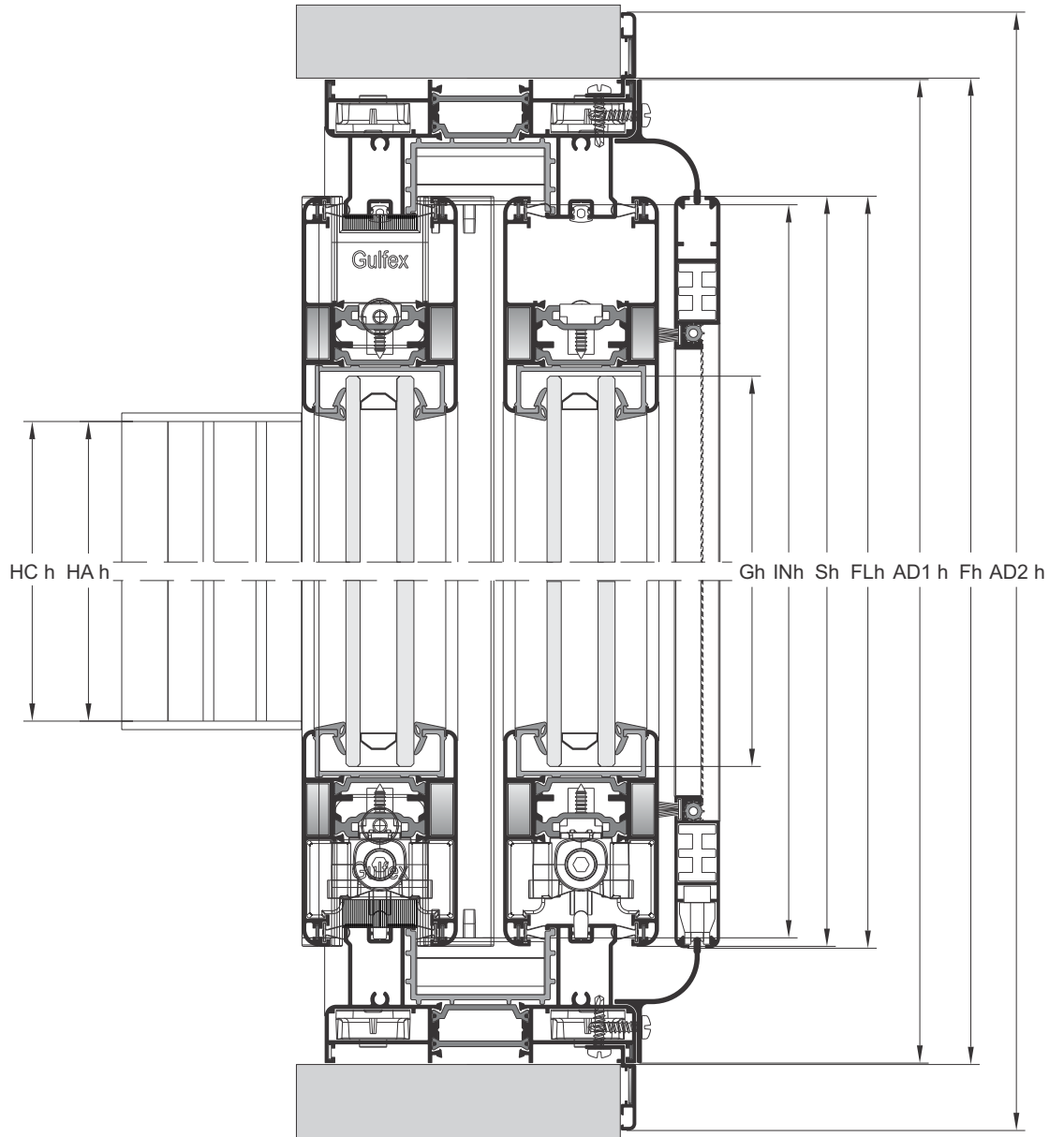
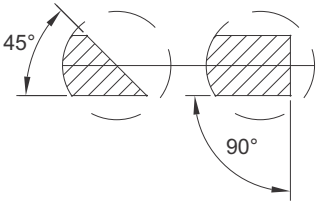

| Cutting table | | | |
|-------------------------------------|-------|--------|--|
| Profile Name | Code | Symbol | Quantity / Cutting |
| Double driver | 83401 | | 2 $\triangle Fw$ |
| | | | 2 $\triangle Fh$ |
| Sash | 83211 | | 6 $\triangle Sw = \frac{Fw - 40,6}{3}$ |
| | | | 6 $\triangle Sh = Fh - 82,4$ |
| Interlock | 26030 | | 4 $\square INh = Sh - 6$ |
| Add-on Profile (Fly screen rail) | 26059 | | 2 $\triangle AD1w = Fw$ |
| | | | 2 $\triangle AD1h = Fh$ |
| Add-on Profile (Wall cover) | 26060 | | 2 $\triangle AD2w = Fw + 47,6$ |
| | | | 2 $\triangle AD2h = Fh + 47,6$ |



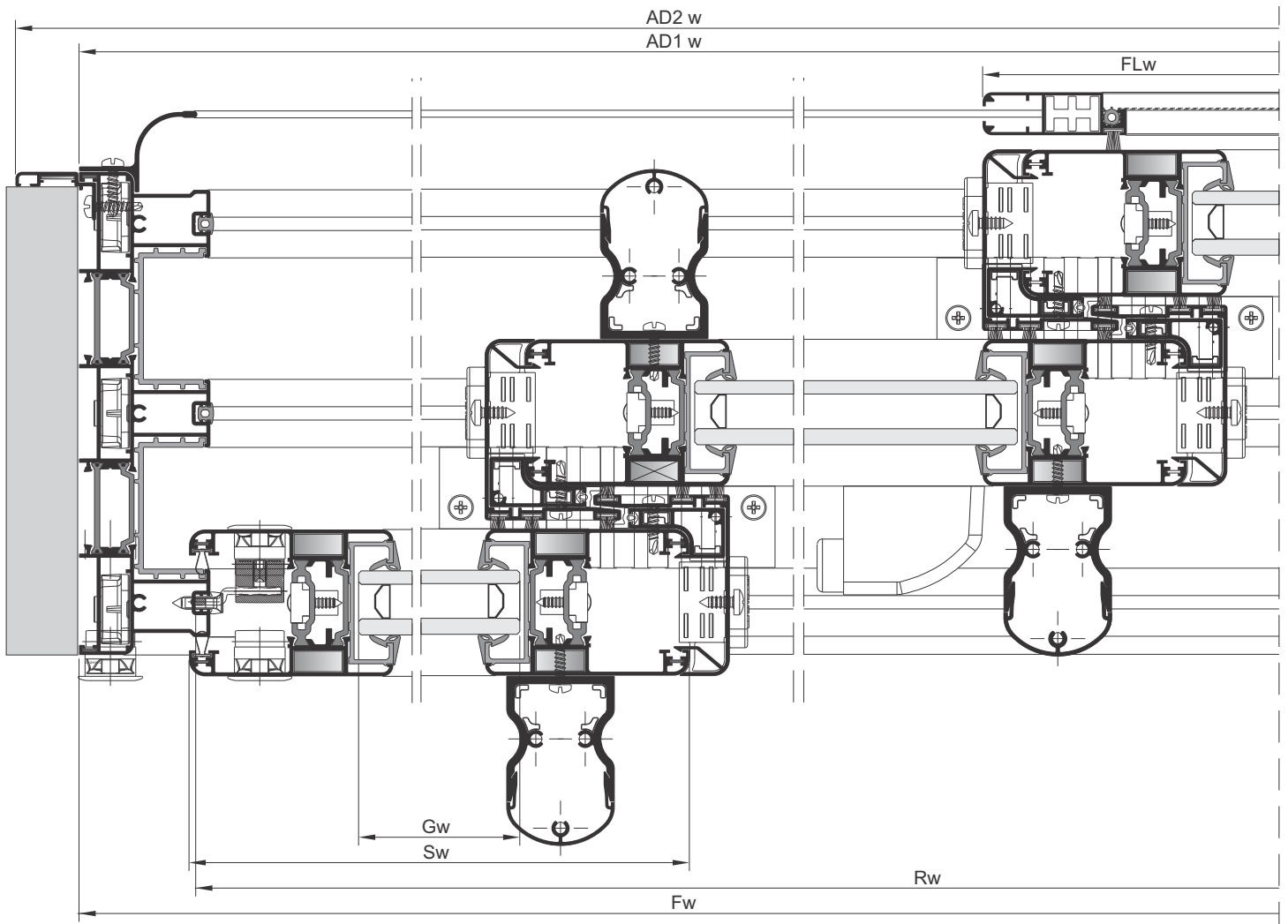

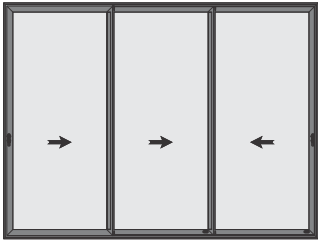

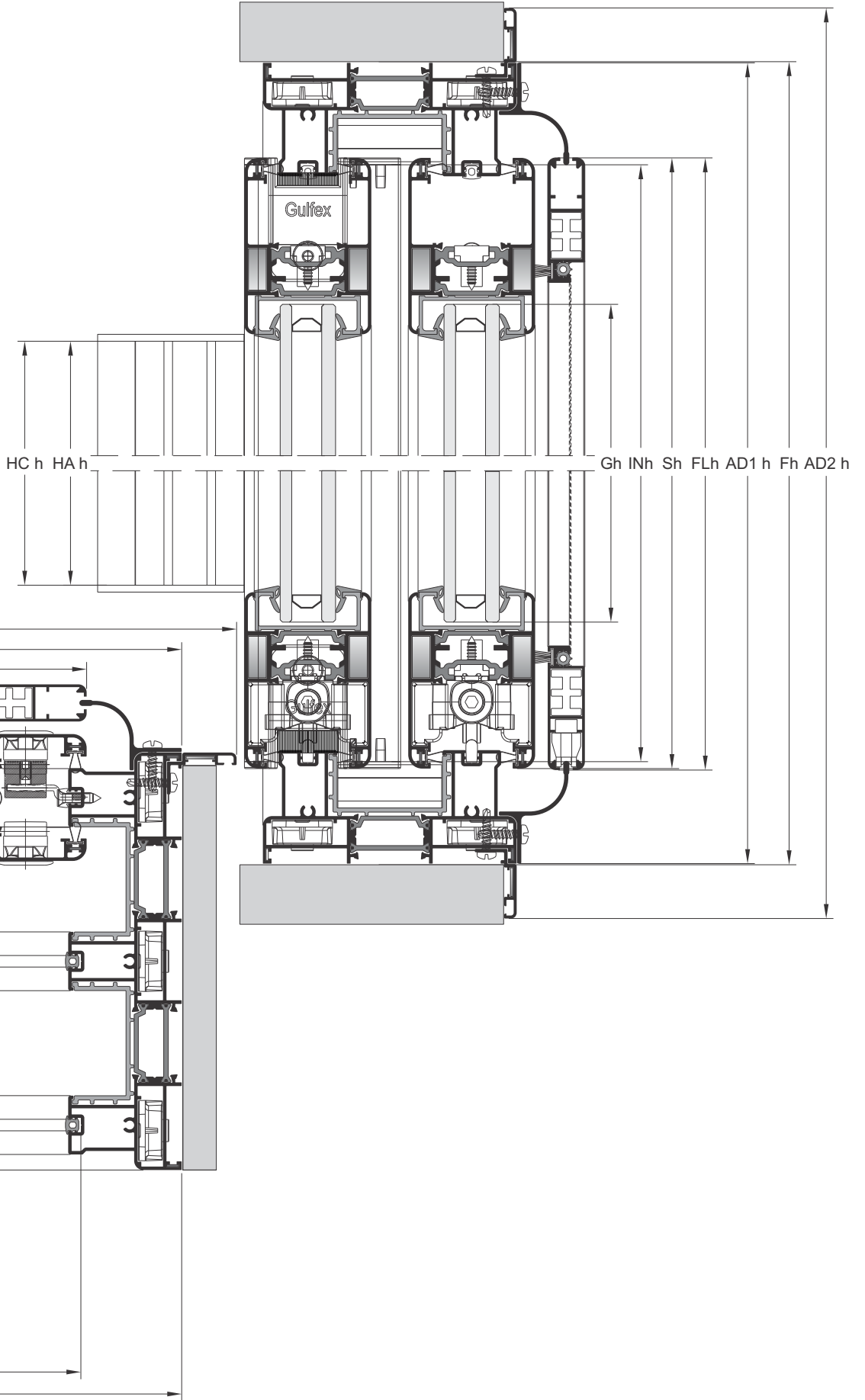
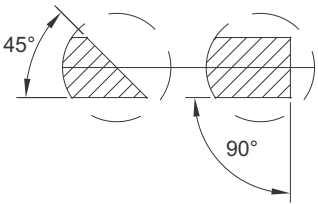

| Profile Name | Code | Symbol | Quantity / Cutting |
|--------------|-------|--------|--|
| Fly screen | 28101 | | 2 $\triangle FLw = Sw + 15$ |
| | | | 2 $\triangle FLh = Sh$ |
| Handle | 26040 | | 3 $\square HAh = Sh - 159$ |
| Handle cover | 26041 | | 3 $\square HCh = Sh - 159$ |
| Rail guide | 26029 | | 3 $\square Rw = Fw - 90$ |
| Glazing | - | | 3 $\square Gw = Sw - 127$ $\square Gh = Sh - 127$ |

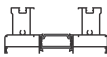

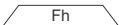





Cutting Angles

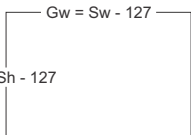

| Cutting table | | | |
|-------------------------------------|-------|---|---|
| Profile Name | Code | Symbol | Quantity / Cutting |
| Double driver | 83401 |  | 2  |
| | | | 2  |
| Sash | 83211 |  | 4 $Sw = \frac{Fw + 33,6}{4}$ |
| | | | 4 $Sh = Fh - 82,4$ |
| Interlock | 26030 |  | 2 $INh = Sh - 6$ |
| Add-on Profile (Fly screen rail) | 26059 |  | 2 $AD1w = Fw$ |
| | | | 2 $AD1h = Fh$ |
| Add-on Profile (Wall cover) | 26060 |  | 2 $AD2w = Fw + 47,6$ |
| | | | 2 $AD2h = Fh + 47,6$ |
| Fly screen | 28101 |  | 2 $FLw = Sw + 15$ |
| | | | 2 $FLh = Sh$ |

| Profile Name | Code | Symbol | Quantity / Cutting |
|--------------------------|-------|---|--------------------|
| Handle | 26040 |  | 1 $HAh = Sh - 159$ |
| Handle cover | 26041 |  | 1 $HCh = Sh - 159$ |
| Rail guide | 26029 |  | 2 $Rw = Fw - 90$ |
| Meeting stile profile | 28094 |  | 1 $M1h = Sh - 37$ |
| Meeting stile profile 02 | 28095 |  | 1 $M2h = Sh - 230$ |
| Glazing | - |  | 2 $Gh = Sh - 127$ |

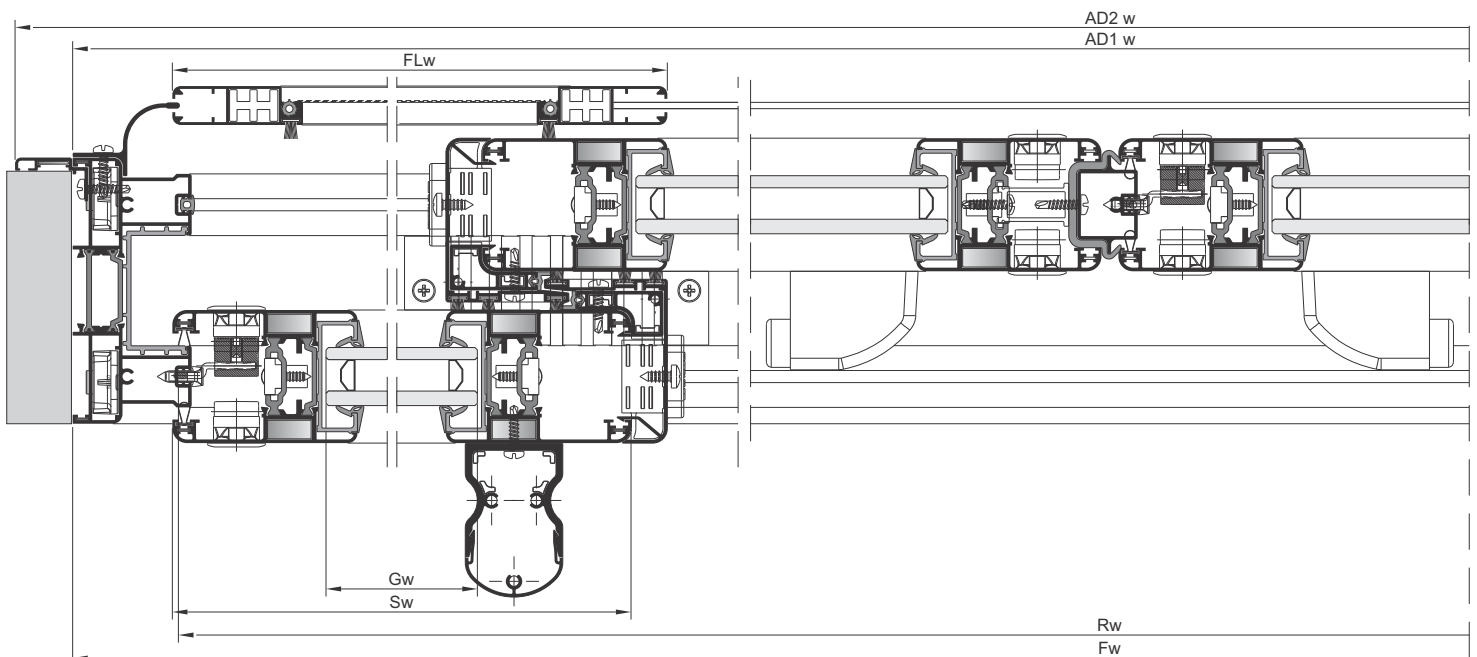

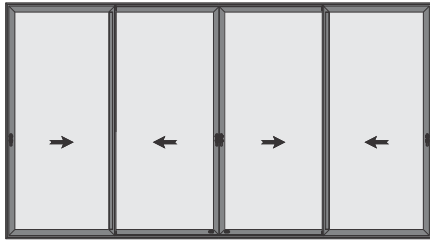

Cutting Angles

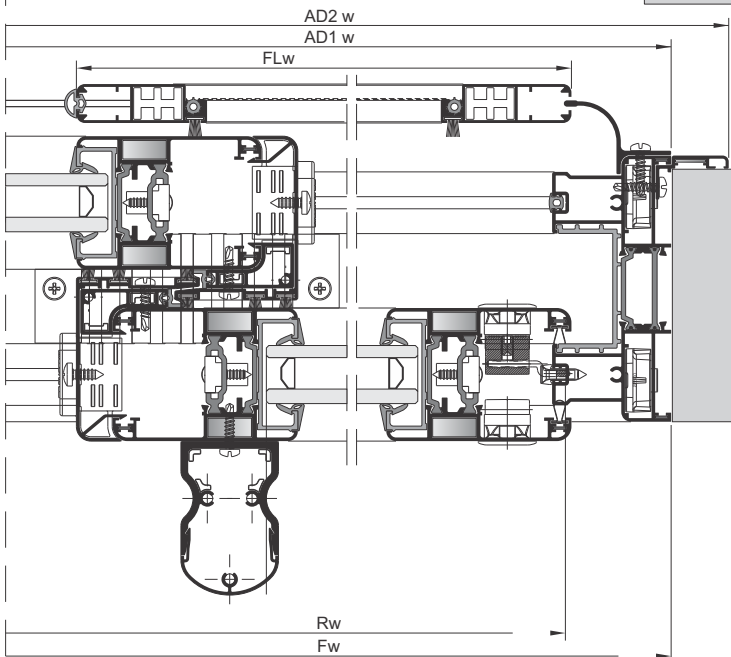
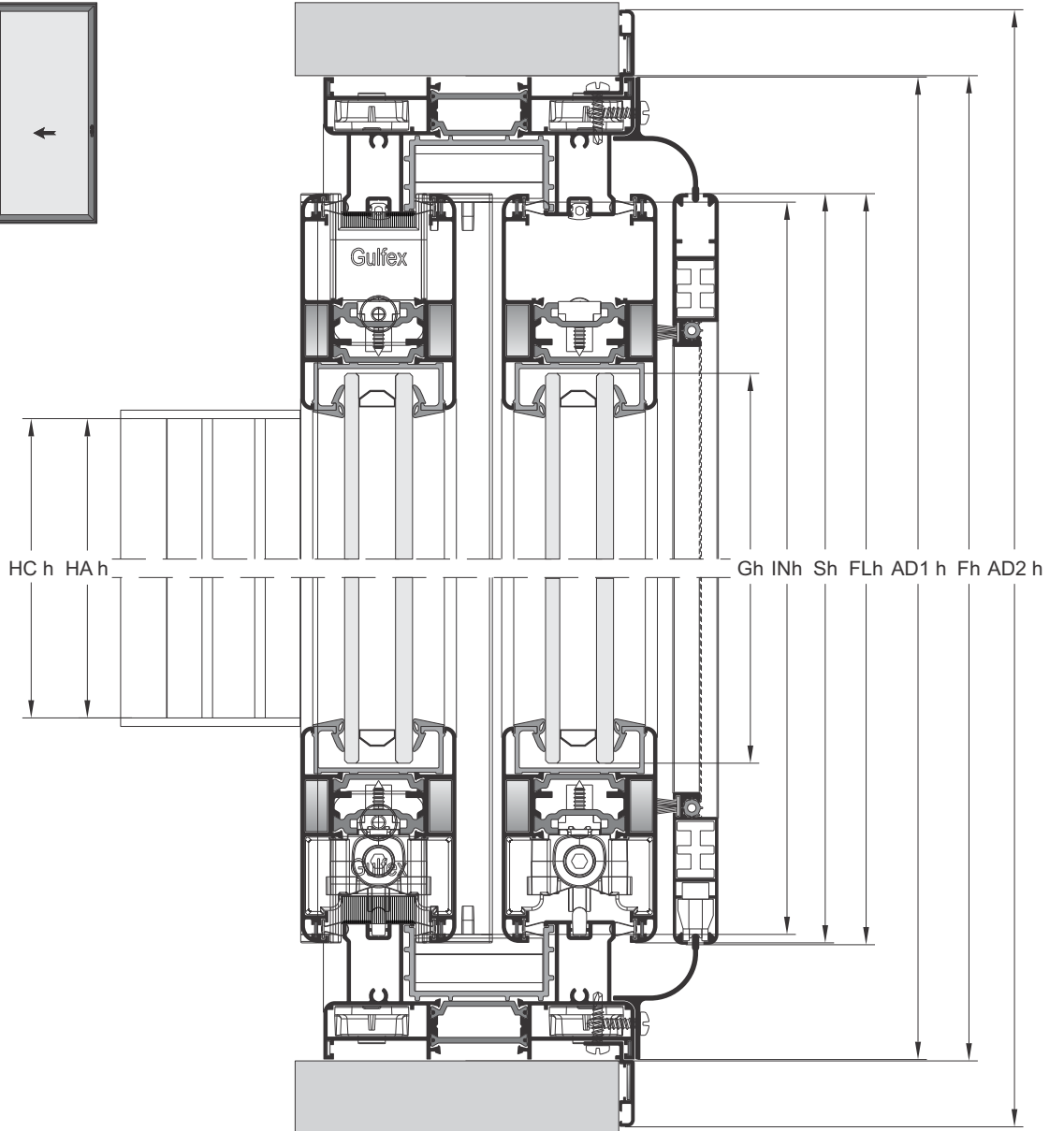
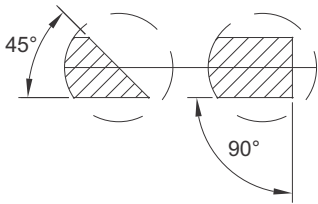

Handwriting practice area with 20 horizontal dashed lines.