

Curtain Wall 60mm

11-2014-V.03

All rights reserved.

No part of this publication may be reproduced, stored in a retrieval system or transmitted in any form or by any means electronic, mechanical, photocopying, recording or otherwise, without prior permission of Gulf Extrusions.

Curtain Wall 60mm

60 - A	GULF EXTRUSIONS	03
60 - B	QUALITY AND CERTIFICATIONS	04 - 09
60 - C	INTRODUCTION TO THE SYSTEM	10
60 - D	PROFILES	11 - 35
60 - E	PROFILE LIST	37 - 48
60 - F	ACCESSORIES	49 - 51
60 - G	ASSEMBLY DRAWINGS	53 - 85
60 - H	3D SECTIONS	87 - 91

GULF EXTRUSIONS

Gulf Extrusions Co. LLC, the flagship company of the Al Ghurair Group of Companies, was founded in 1978, Dubai, UAE where it has over the years earned the reputation known as one of the most innovative and reliable companies in the Middle East.

Located close to its raw material supplier Dubai Aluminium Company Ltd (DUBAL), the world's largest single smelter site, Gulf Extrusions has become one of the largest extrusion plants in the region.

Gulf Extrusions quality products can be seen in many of today's progressive structures. The company was formed with the sole purpose to meet the increasing demands for aluminium extrusions in domestic, regional and international markets.

Gulf Extrusions six presses and highly skilled workforce are able to produce 65,000 metric tonnes per annum with a rated capacity of 24,000 tonnes for powder coated finish, 6,000 tonnes for anodized finish and can offer more than 10,000 profile designs. These extrusions cover numerous industries ranging from architectural to transportation, engineering to structural sections, components for household items, HVAC and customized products.

During the progressive stages of Gulf Extrusions, from its inception to expansion, the company not only has acquired a majority share in the local market, it has also made its presence felt globally throughout the GCC countries, Indian sub -continent, South East Asia, Australia, Africa, Europe and Canada.

Our commitment and utmost priority is to provide customers with the finest quality of aluminium extrusions.

Gulf Extrusions looks ahead to inevitable challenges and product advancements of the new era.

Quality is an inseparable element of all activities carried out at Gulf Extrusions. Gulf Extrusions is dedicated to respond and deliver on time, high quality, tailor-made and cost effective products. The management and staff are committed to implement a comprehensive and integrated Quality Management System in accordance with the International Quality Standards of ISO 9001 and ISO 14001.

INTERNATIONAL STANDARD COMPLIANCE

Extrusions Dimensions Tolerances:

- BS EN 755 - 9:2008
- BS EN 12020 - 2:2008
- DIN 1748, DIN 17615
- ASTM B221

Powder Coated Finish:

- BS:6496 Clause: 10.4, 10.5, 10.6, 10.7 & 10.8
- ISO 2360 / 2813 / 2409 / 2931
- Minimum Film Thickness – 60 Microns

Anodizing Finish:

- BS EN 12373-1 2001 Clause 7 (BS:6161 Part 6)
- BS:3987 Clause 2, 3, 5, 6
- Appendix- A, B, C, D, E, F, G, H, J, K, L Minimum Film Thickness- 16 Microns



PRODUCT QUALITY CERTIFICATES



Qualicoat (European Powder Coaters Association):

- A quality label for coating on metal for Architectural Applications
- A product license under the control of EWAA (European Wrought Aluminium Association) in Zurich Switzerland



Qualanod (European Anodizers Association):

- A quality label organization to guarantee high quality Aluminium Anodizing.
- A product license under the control of EWAA (European Wrought Aluminum Association) in Zurich Switzerland



- SASO



- ESMA



Management:

- ISO 9001 (Quality Management System)



- ISO/TS 16949:2009 (Management System)



Environment:

- ISO 14001 (Environment Management System)



Membership in International Organization:

- AAC member (Aluminium Anodizers Council - USA)
- AEC member (Aluminum Extruders Council - USA)
- DIN EN 15088

CHEMICAL COMPOSITIONS

ALLOY 6005A

Element	Minimum	Maximum
Si	0.50	0.90
Fe	-	0.35
Cu	-	0.30
Mn	-	0.50
Mg	0.40	0.70
Cr	-	0.30
Zn	-	0.20
Ti	-	0.10
Other Each	-	0.05
Other Total	-	0.15
Aluminium	Remainder	

ALLOY 6060

Element	Minimum	Maximum
Si	0.30	0.60
Fe	0.10	0.30
Cu	-	0.10
Mn	-	0.10
Mg	0.35	0.60
Cr	-	0.05
Zn	-	0.15
Ti	-	0.10
Other Each	-	0.05
Other Total	-	0.15
Aluminium	Remainder	

ALLOY 6063

Element	Minimum	Maximum
Si	0.20	0.60
Fe	-	0.35
Cu	-	0.10
Mn	-	0.10
Mg	0.45	0.90
Cr	-	0.10
Zn	-	0.10
Ti	-	0.10
Other Each	-	0.05
Other Total	-	0.15
Aluminium	Remainder	

ALLOY 6082

Element	Minimum	Maximum
Si	0.70	1.30
Fe	-	0.50
Cu	-	0.10
Mn	0.40	1.00
Mg	0.60	1.20
Cr	0.04	0.15
Zn	-	0.20
Ti	-	0.10
Other Each	-	0.05
Other Total	-	0.15
Aluminium	Remainder	

ALLOY 6061

Element	Minimum	Maximum
Si	0.40	0.80
Fe	-	0.70
Cu	0.15	0.40
Mn	-	0.15
Mg	0.8	1.20
Cr	0.04	0.35
Zn	-	0.25
Ti	-	0.15
Other Each	-	0.05
Other Total	-	0.15
Aluminium	Remainder	

ANODIZING

A wide range of anodizing treatment options are possible for the aluminium profile sections of this system. The color choices from Gulf Extrusions range from Natural, Gold, and Bronze to Spectro colors (Red, Blue, Green, and Gray).

This surface treatment process involves first pre-treatment with scotch brite brushing for the unfinished profiles, and then subsequently fully immersing the aluminium profiles in an acidic electrolyte solution through which electric current is passed creating an anodic film on the profiles ranging from 5-30MICs.

The process is guaranteed and certified for use by QUALANOD - A quality label Organization to guarantee high quality aluminium anodizing and the company's ISO 9001 certification.

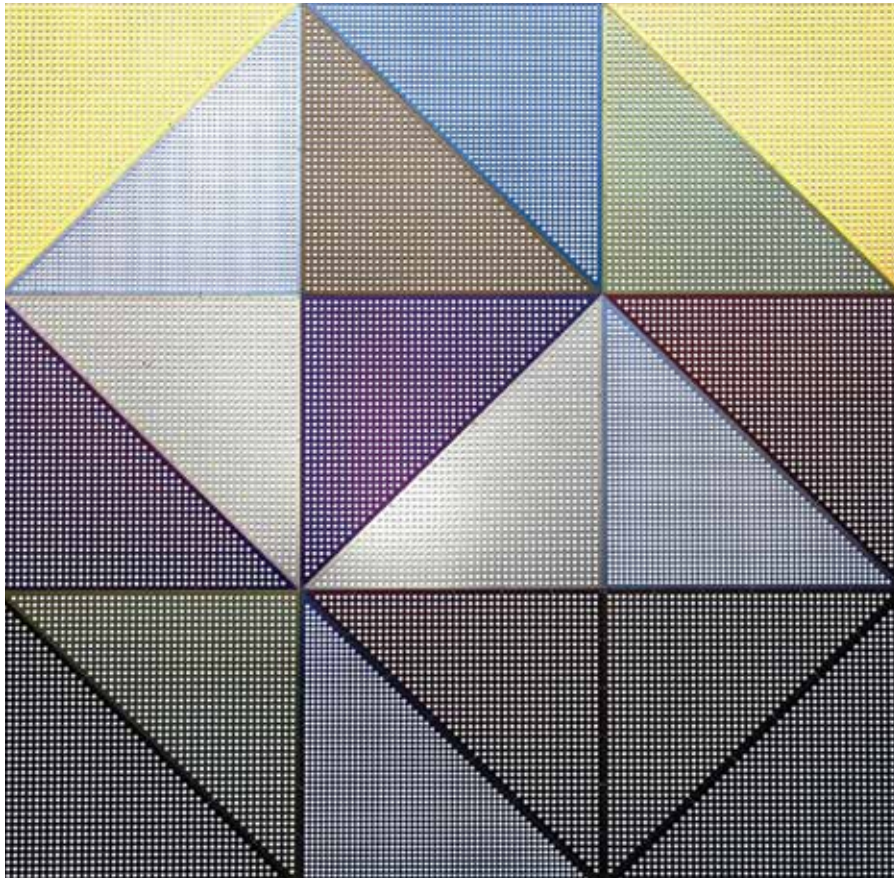

Authorization to use the quality sign



Qualanod

This is to certify that



Gulf Extrusions Co. LLC
 P.O. Box 5508
 AE – 5508 Dubai

Licence number: 2000

is authorized to use the quality sign which is shown above according to the REGULATIONS FOR USE OF THE QUALANOD QUALITY LABEL FOR SULPHURIC ACID-BASED ANODIZING OF ALUMINIUM.

Date of issue of the licence:	10.03.2000
Period of validity of the licence:	until 31.12.2014

Zurich, 15 November 2013

<p>QUALANOD</p>  <p>Timur Ulucak President</p>	<p>CERTIFICATION BODY</p>  <p>Josef Schoppig AC-Fiduciaire SA</p> 
--	---

<p>Mailing address: QUALANOD, P.O. Box 1507, CH-8027 Zurich Domicile: QUALANOD c/o AC-Fiduciaire SA, Tödistrasse 47, CH-8002 Zurich</p>	<p>Phone: +41 (0)43 305 09 70 Fax: +41 (0)43 305 09 98 E-mail: info@qualanod.net Internet: www.qualanod.net</p>
--	--

POWDER COATING

- Horizontal & Vertical Powder coating lines with an Annual Capacity of 24 000 MT
Powder Coating BS: 6496 Clause: 10.4, 10.5, 10.6, 10.7, & 10.8
ISO 2360/2813/2409/2931
Minimum Film Thickness - 60 Microns

A wide choice of colors for powder coating can be used for the aluminium profile sections.

From Gulf Extrusions the following powder types are available

- Polyester Façade (PE-F)
- Super Durable Façade (SDF) & Hyper Durable Façade (HDF) (Where SDF & HDF are equivalent to Poly-Vinylidene DiFluoride (PVDF) in terms of corrosion performance)
- Anti Bacterial (recommended to be used in Hospitals)
- Anti Static (recommended for laboratories, electronics assembly buildings) and Heat Resistant in nature.

This surface treatment process involves the following pre-treatment

1. Degreasing
2. Washing
3. Etching
4. Washing
5. Chromatising
6. Double washing in dematerialized water

Once completed, powder is applied using an electrostatic spraying process with charged powder particles, followed by curing in an oven under a controlled temperature of 180-200C for paint polymerization where the paint layer is at least 60mic.

This whole process is certified for use from QUALICOAT - A quality label for coating on metal for Architectural Applications.

GUARANTEE PERIOD:
10 years for PE-F Quality
25 years for PE-SDF

Authorization to use the quality sign



This is to certify that

Gulf Extrusions Co. Ltd

P.O. Box 5598
AE – 5598 Dubai

Licence number: 1901

is authorized to use the quality sign which is shown above according to the REGULATIONS FOR THE USE OF THE QUALICOAT QUALITY SIGN FOR PAINT, LACQUER AND POWDER COATINGS ON ALUMINIUM FOR ARCHITECTURAL APPLICATIONS.

Date of issue of the licence: 15.03.2000
Period of validity of the licence: until 31.12.2014

Zurich, 17 December 2013

QUALICOAT

CERTIFICATION BODY

M.C. Panam

Josef Schoppig

Mohammed C. Panam
President

Josef Schoppig
AC-Fiduciaire SA



Mailing address:
QUALICOAT, P.O. Box 1507, CH-8027 Zurich
Domicile:
QUALICOAT c/o AC-Fiduciaire SA, Tödistrasse 47, CH-8002 Zurich

Phone: +41 (0)43 305 09 70/79
Fax: +41 (0)43 305 09 98
E-mail: info@qualicoat.net
Internet: www.qualicoat.net

INTRODUCTION TO THE SYSTEM

CW 60 is a unique curtain wall structure that combines multi-structural grid to create various aspects, starting by the conventional curtain wall system passing through the two way horizontal capping curtain wall systems to the four way structural curtain wall systems.

CW 60 has proven to be a curtain wall solution perfectly tailored to the Middle East market requirement.

FEATURES:

The CW 60 system consists of 60mm width structure components allowing several external appearances. It is fast to manufacture and to install. With the wide range of profile selection, the system can provide the possibility of large glass panels, maintaining the stiffness and rigidity of the curtain wall structure. Mullions can be reinforced by Aluminium or Steel tubes to enhance the free span area, making it possible to be used in high structures

Special casements for the CW 60 system have been developed giving two options of cold and thermally insulated profiles. Casements are Italian openings with selected stay arms to ensure the tightness and stability of the opening.

CW 60 uses the same structures for multifunctional applications:

- Conventional application is obtained by applying horizontal and vertical caps, clipped to horizontal and vertical pressure plates screwed to the structure holding the glass panels. Two EPDM gaskets, one to the inside fixed on the structure, the second to the outside fixed on the pressure plate; provide the grip on the glass panels. Glass thickness ranges between 6mm –32 mm
- Two way or horizontal capping application is obtained by applying horizontal caps only, clipped to a horizontal pressure plate screwed to the structure and holding the glass panels. Two EPDM gaskets applied horizontally one to the inside fixed to the structure; the second to the outside fixed to the pressure plate provide the grip on the glass panels. Vertically only a vertical sealant is applied between the glass panels for aesthetic and water tightness
Glass thickness ranges between 6mm – 32mm
- Four way structural aspects is a curtain wall aspect which conceals that conceals the aluminium structure from the outside making it completely invisible. Concealed openings are designed in order to keep the external appearance of the structure uniform even in the presence of the opening. The four way structural applications is obtained by fixing a glass toggle to the glass holding the panel by a specially designed aluminium spacer, well sealed by a structural sealant to ensure the rigidity of panel. The space between glass panels is sealed by a neutral sealant for aesthetic and water tightness purposes; this application is the most common application in the MENA region. Glass thickness is of 32 mm if panel is composed of Xmm inside- 20 mm airspace-8 mm outside the glass thickness can vary if we change the outer glass thickness uniformly on the façade.

PROFILES

Mullion / Transom Profiles

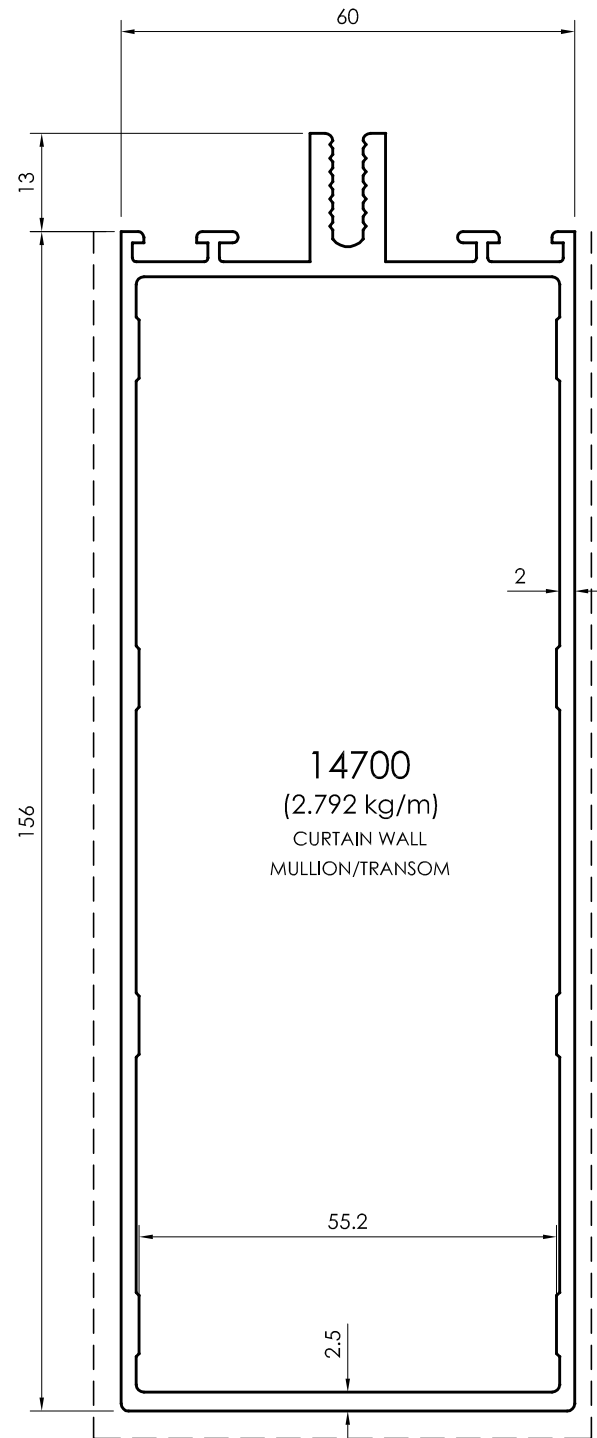
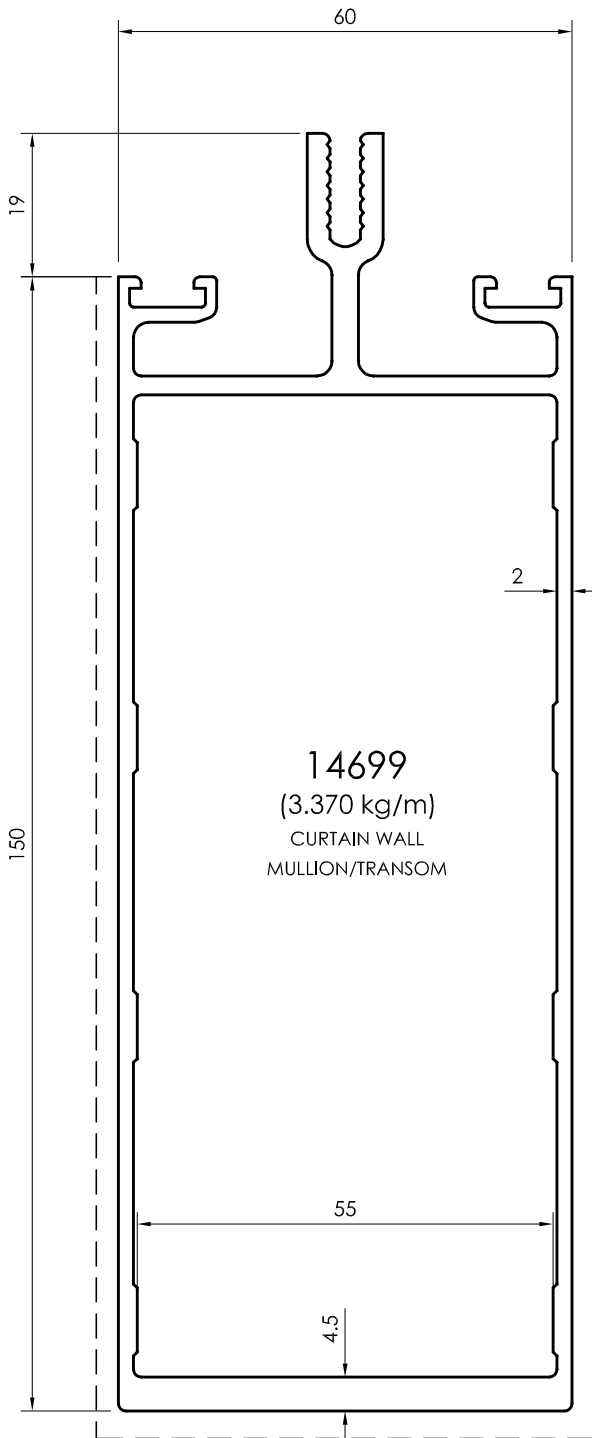

All dimensions in mm
Visible area_____

Mullion / Transom Profiles

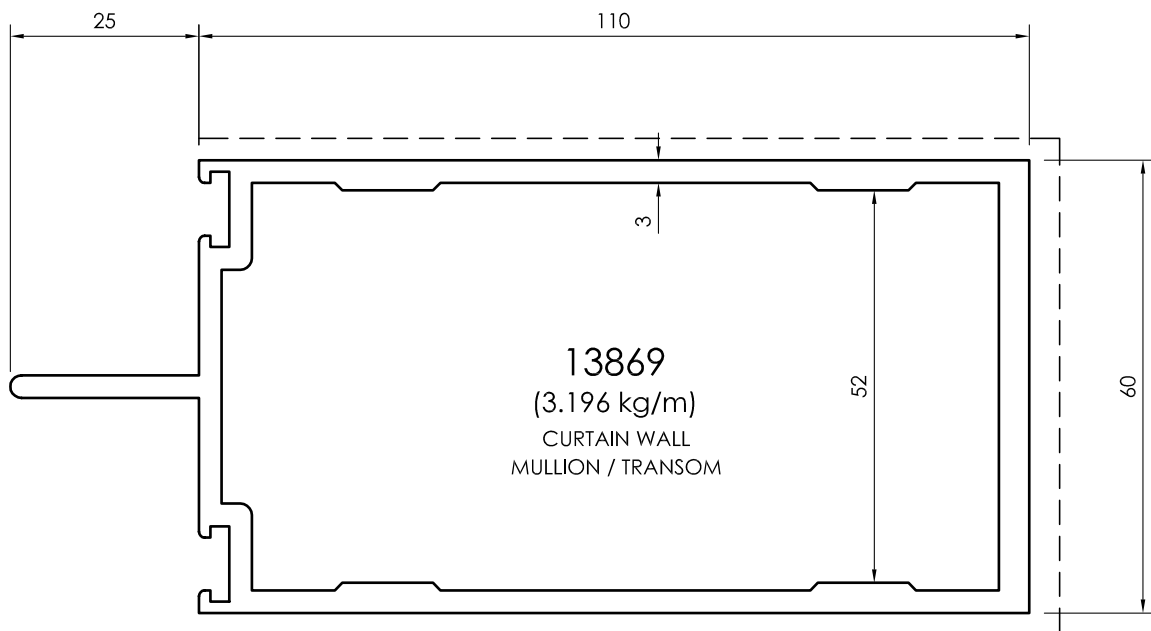
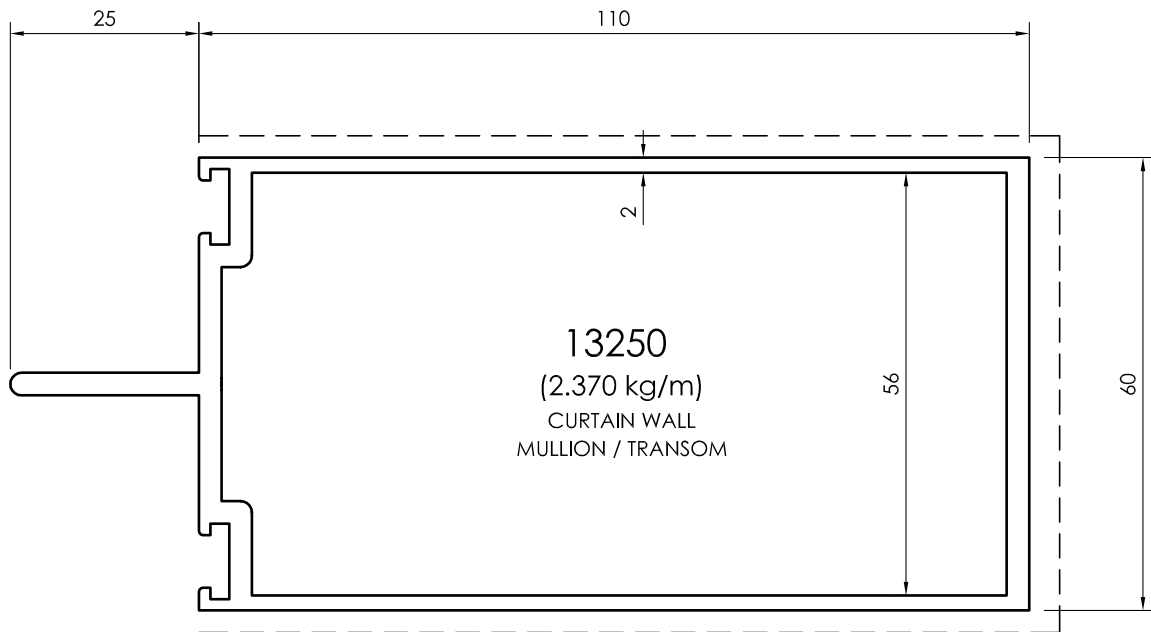

All dimensions in mm
----- Visible area

Mullion / Transom Profiles

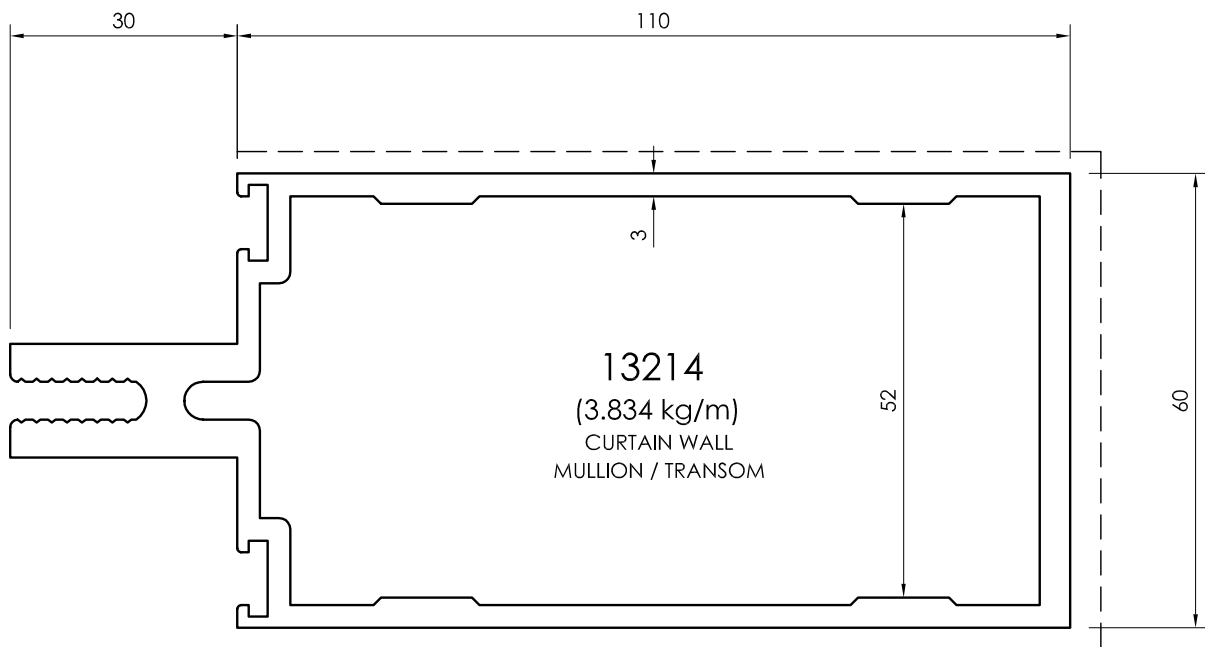
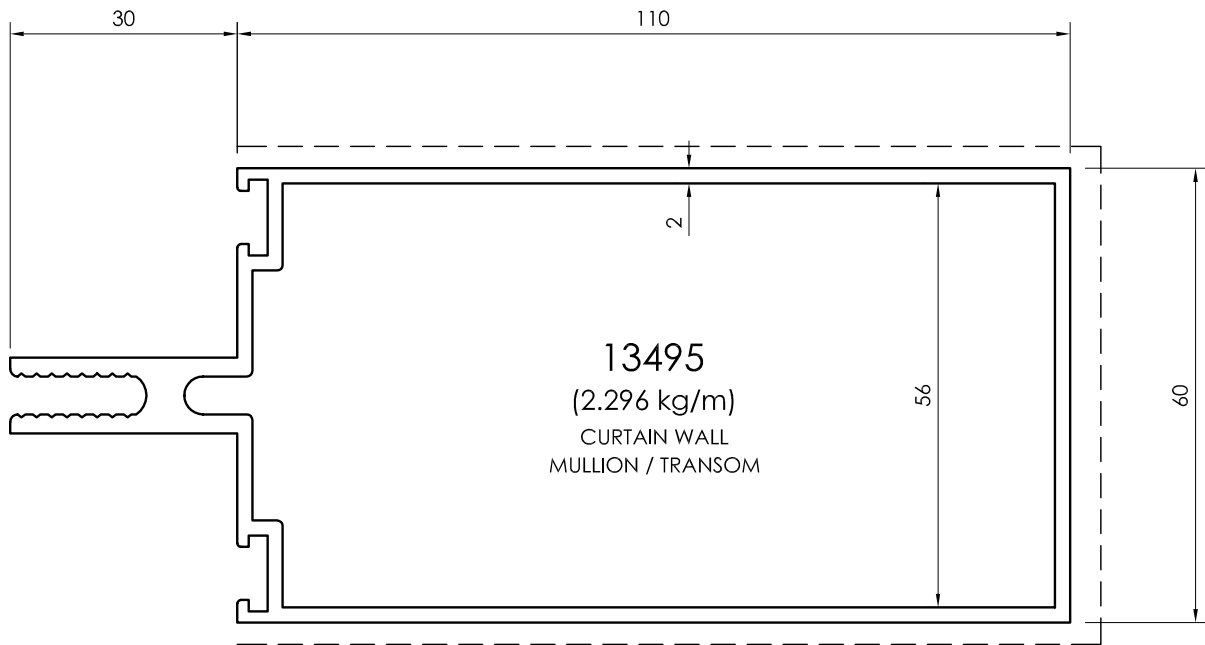

All dimensions in mm
Visible area_____

Mullion / Transom Profiles

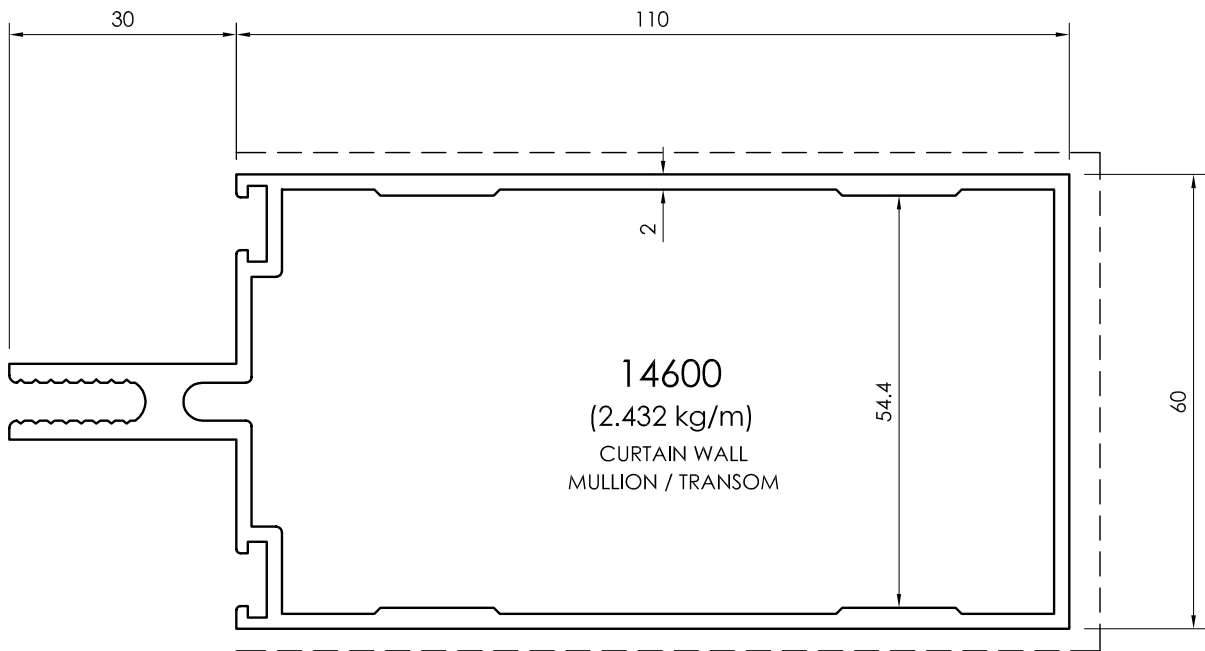
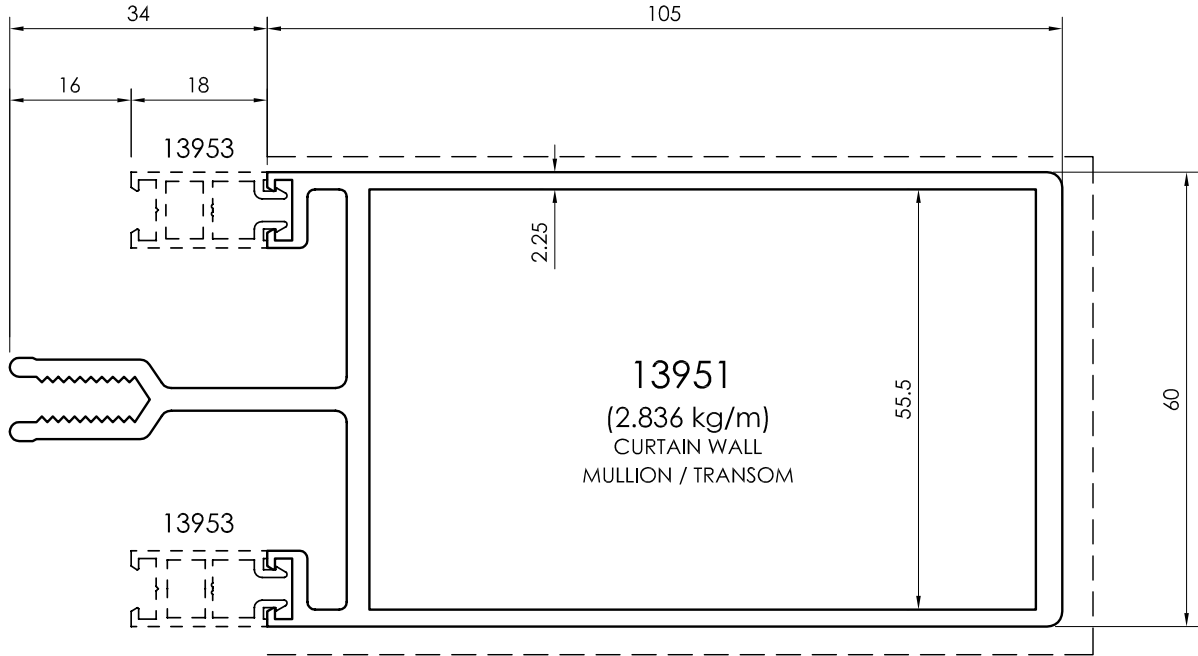

All dimensions in mm
----- Visible area

Mullion / Transom Profiles

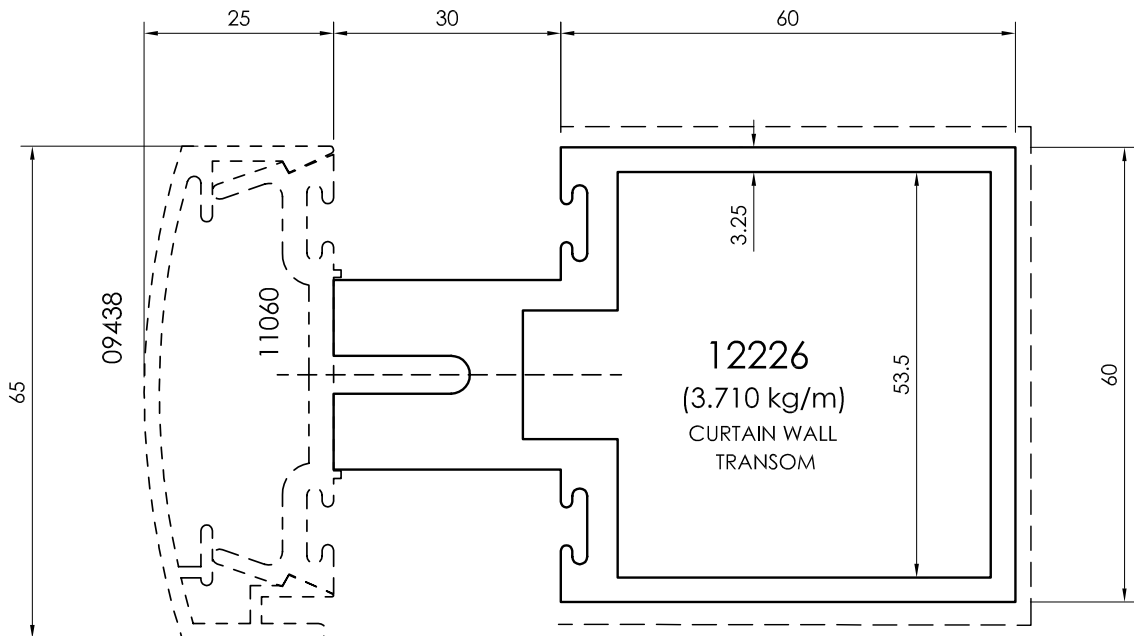
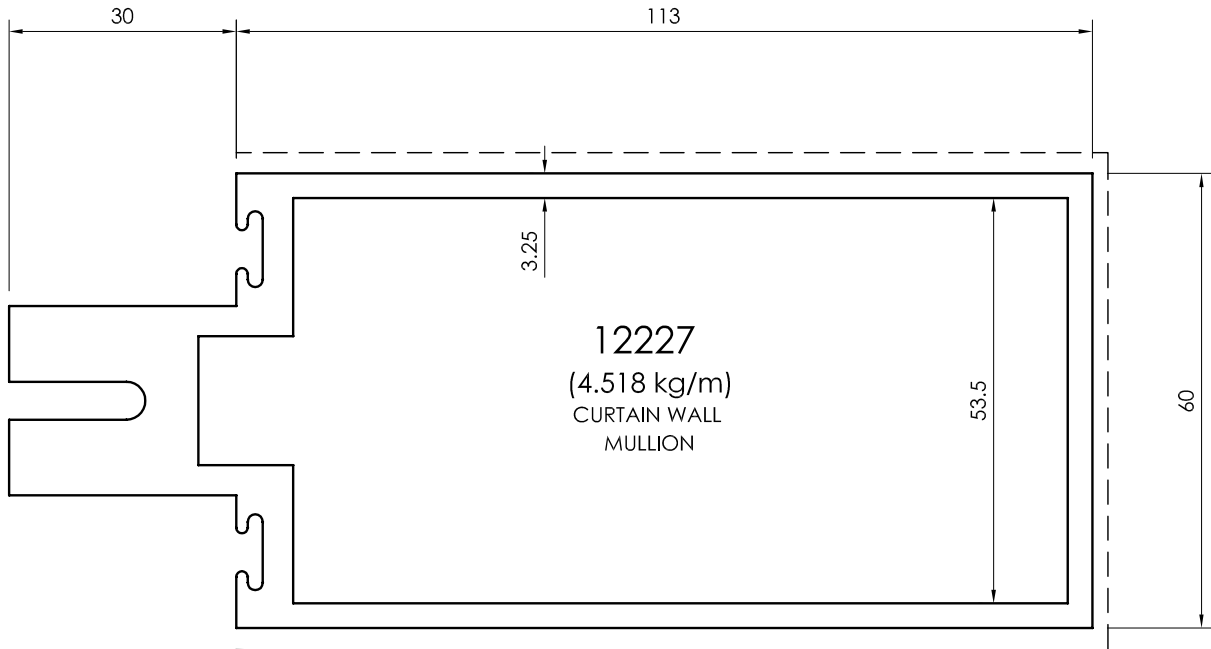

All dimensions in mm
Visible area_____

Mullion / Transom Profiles

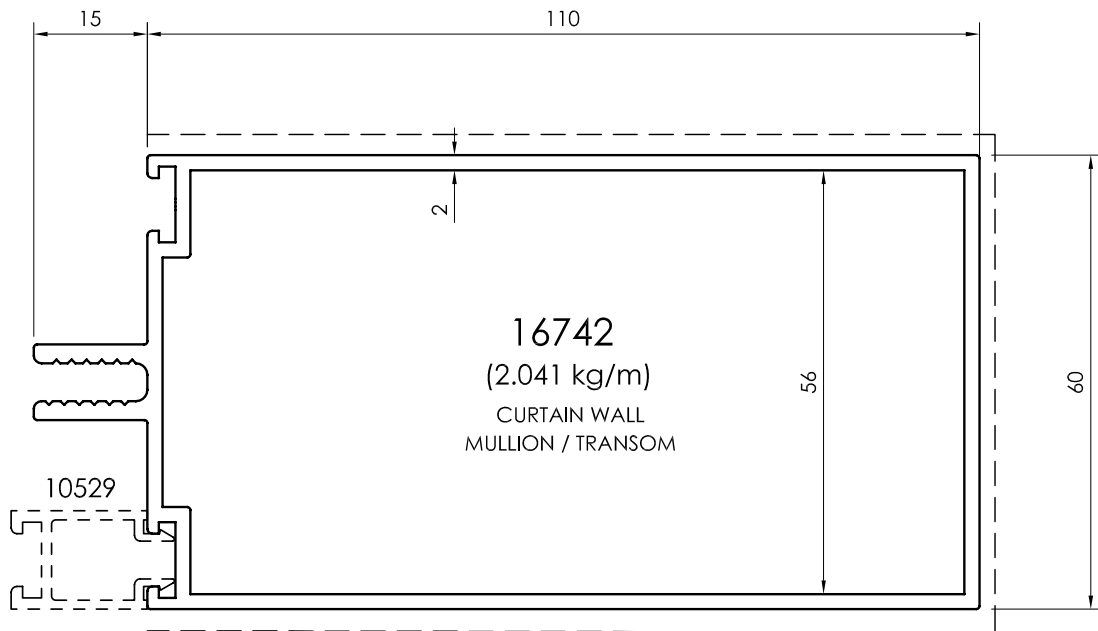
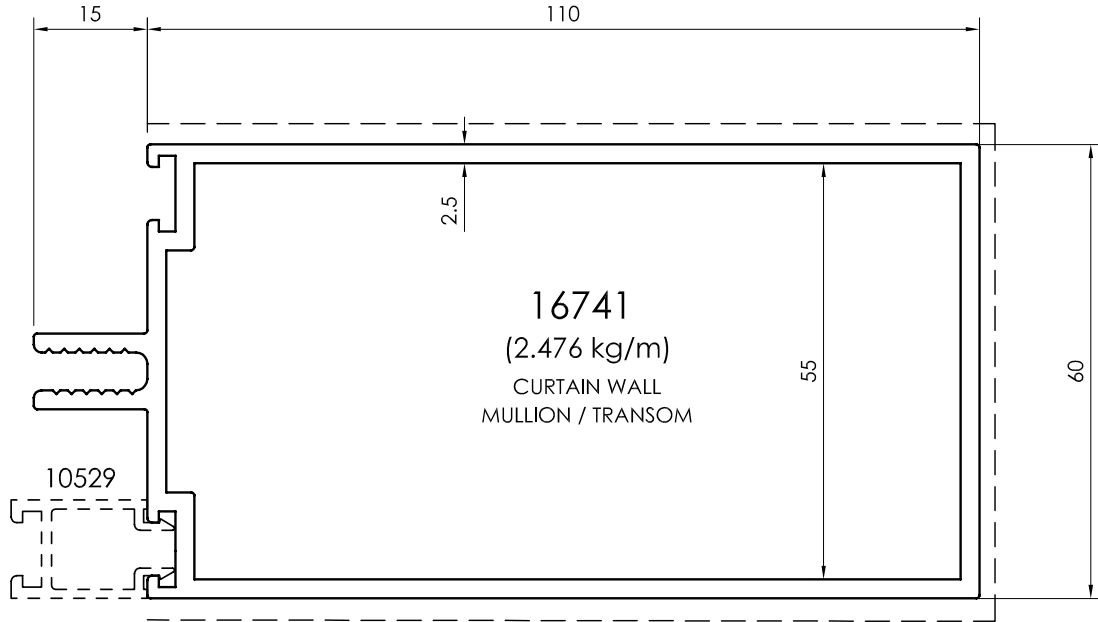

All dimensions in mm
----- Visible area

Mullion / Transom Profiles

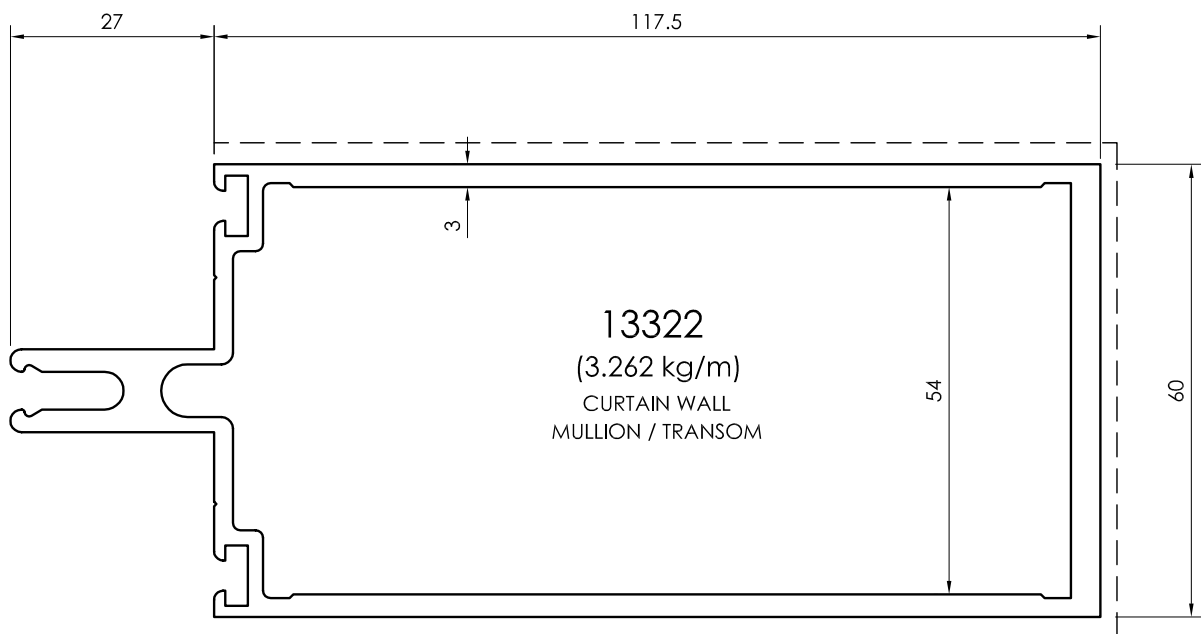
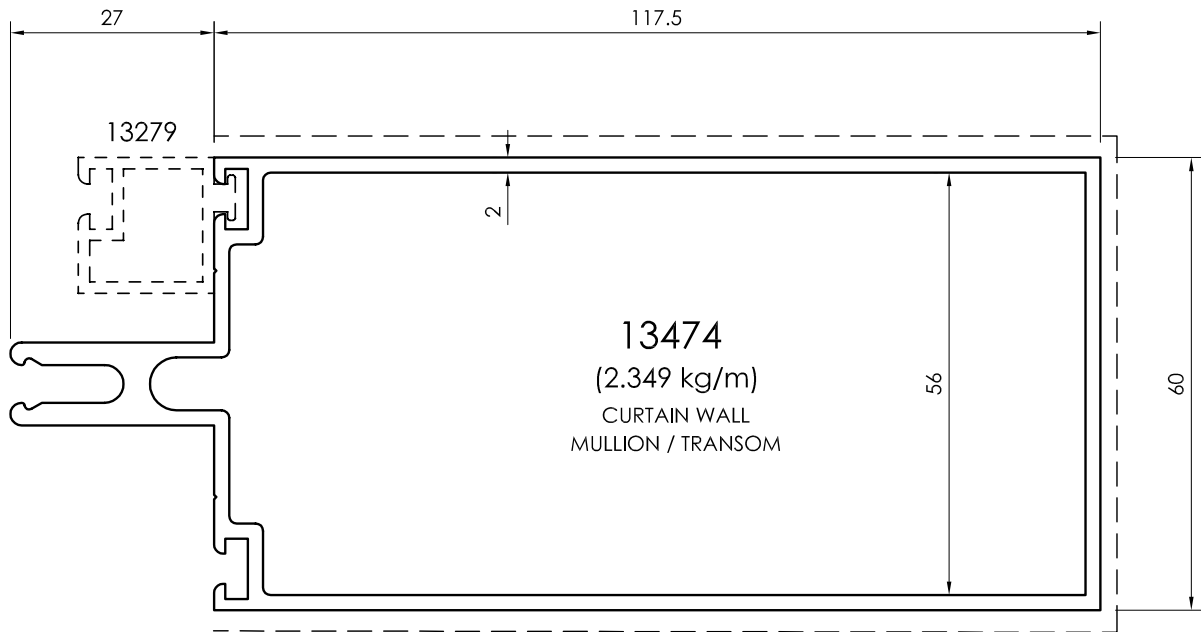

All dimensions in mm
Visible area_____

Mullion / Transom Profiles

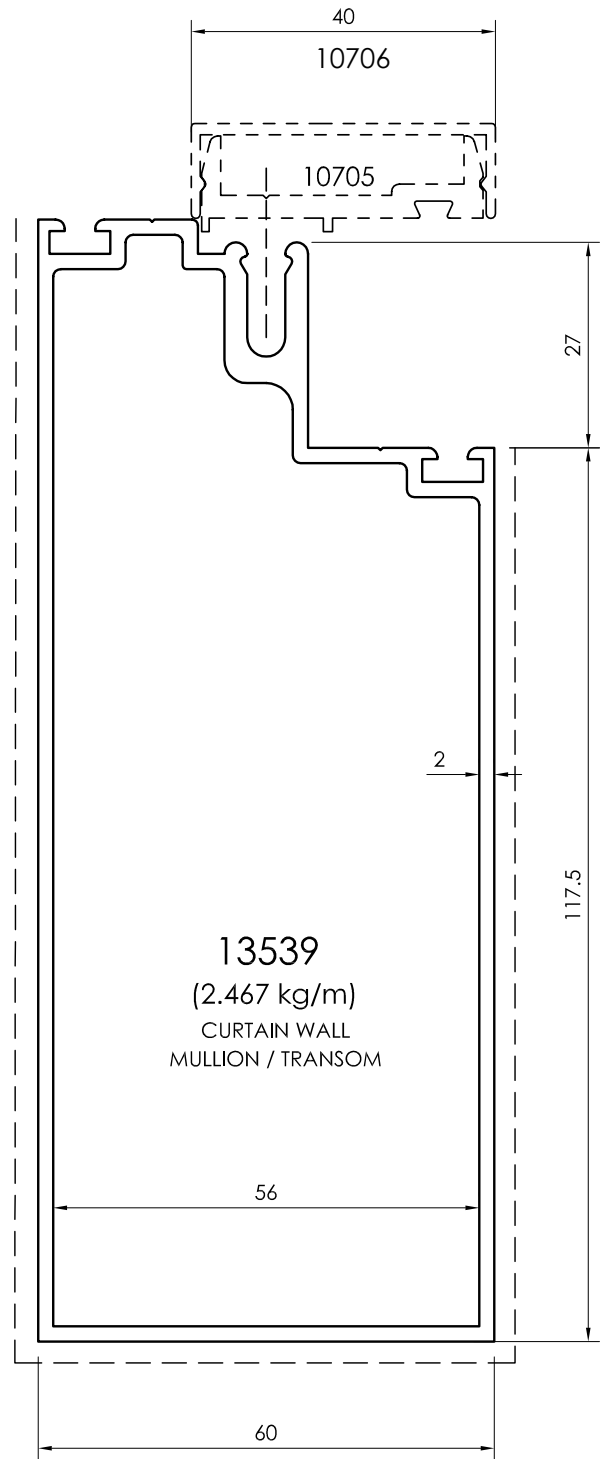
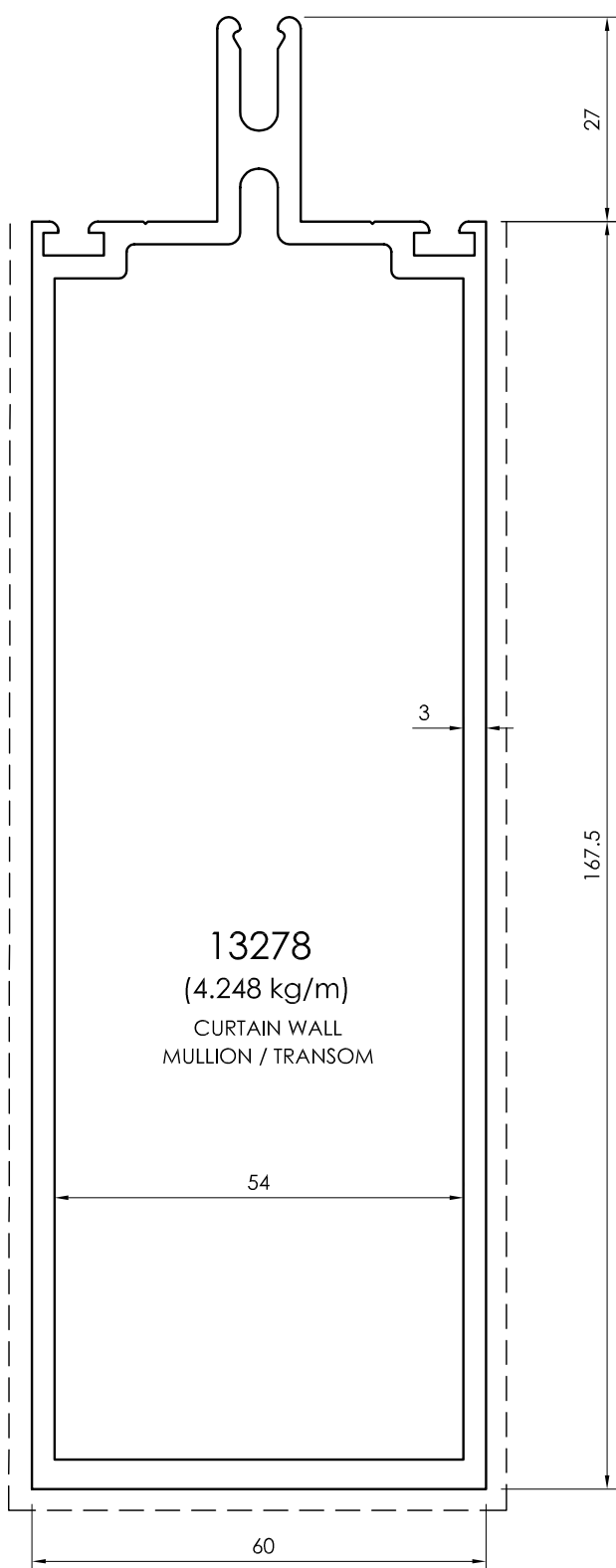

All dimensions in mm
----- Visible area

Mullion / Transom Profiles

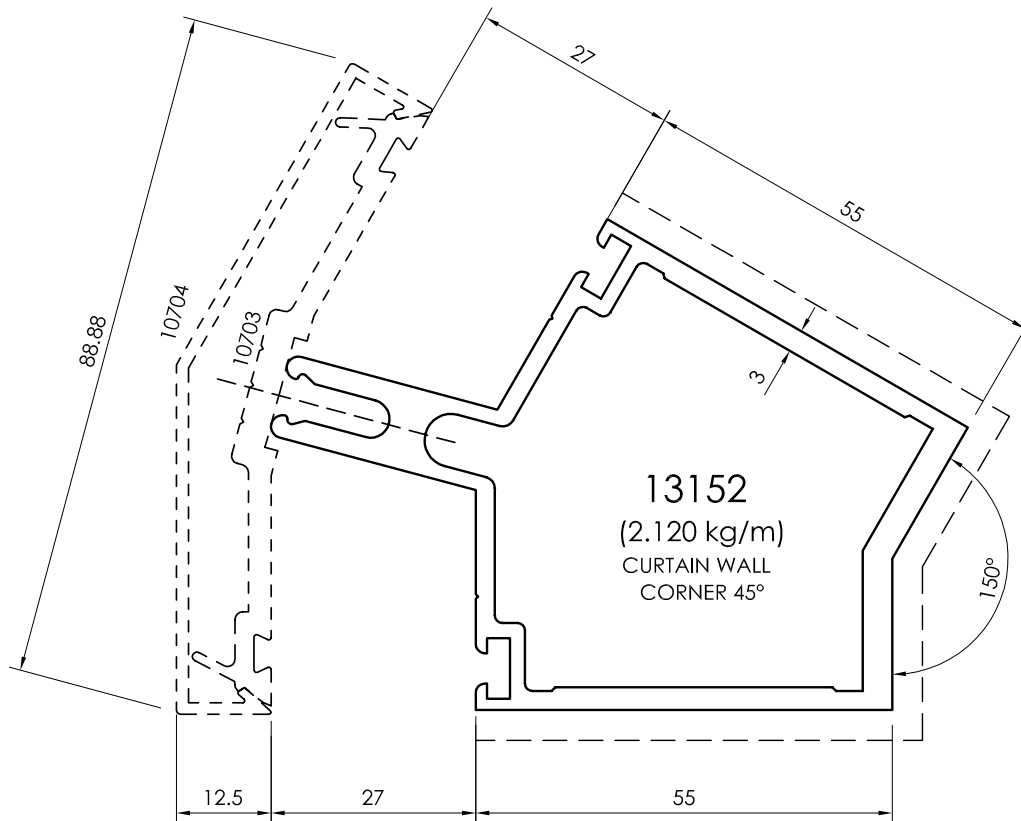
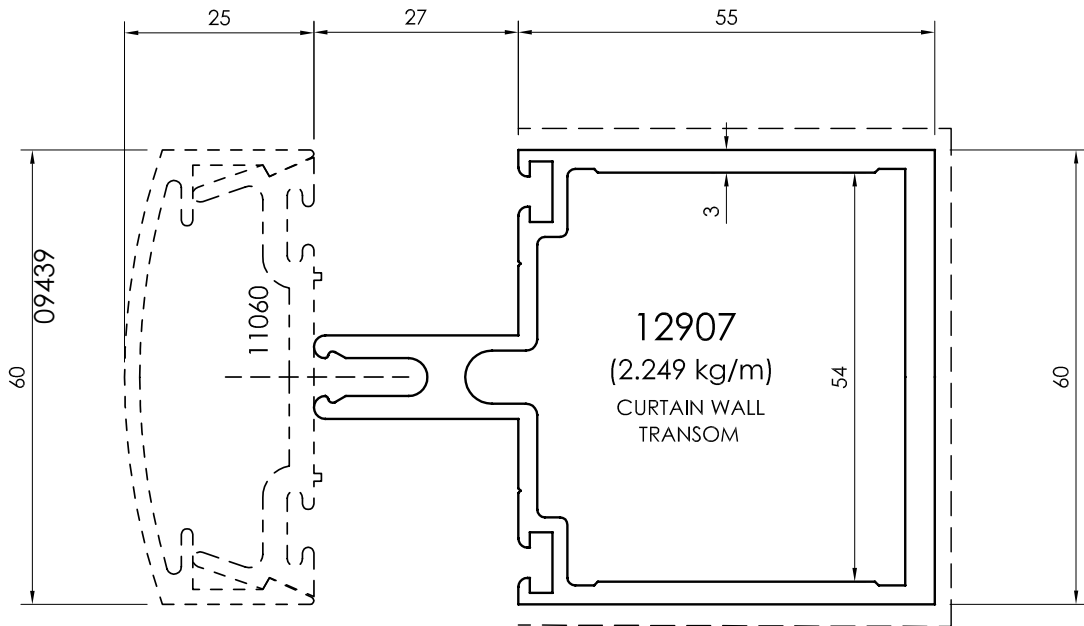

All dimensions in mm
Visible area_____

Mullion / Transom Profiles

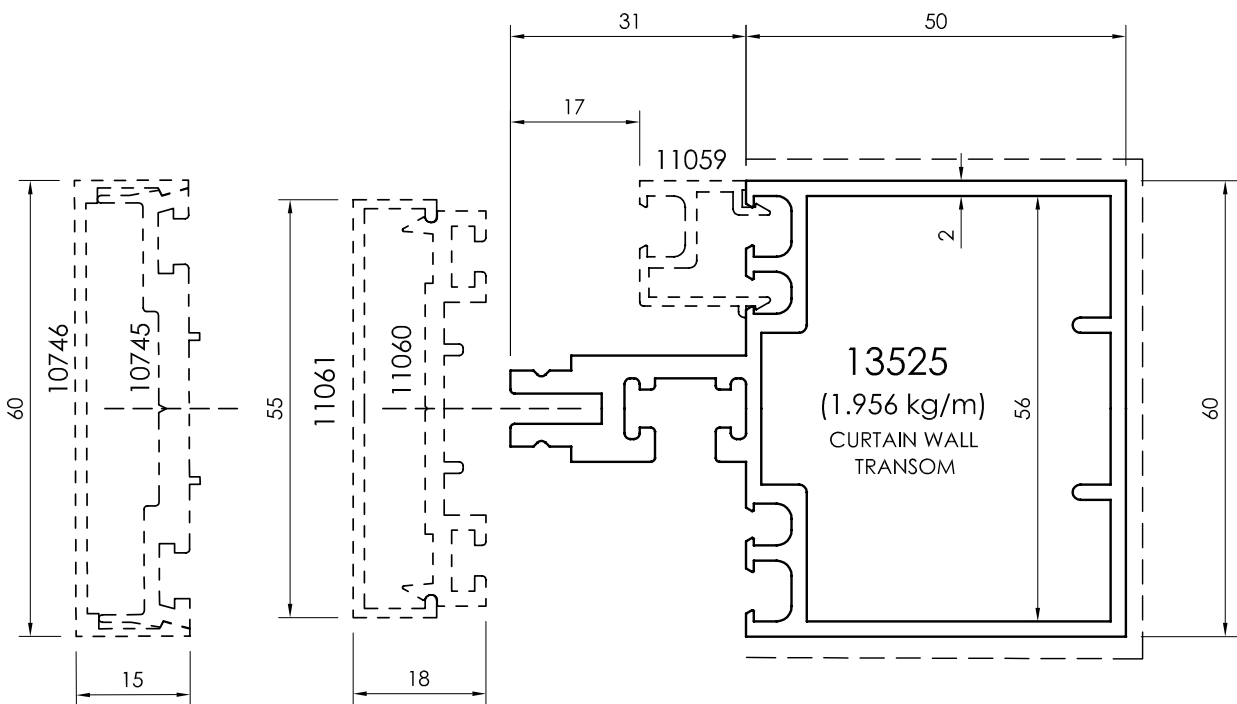
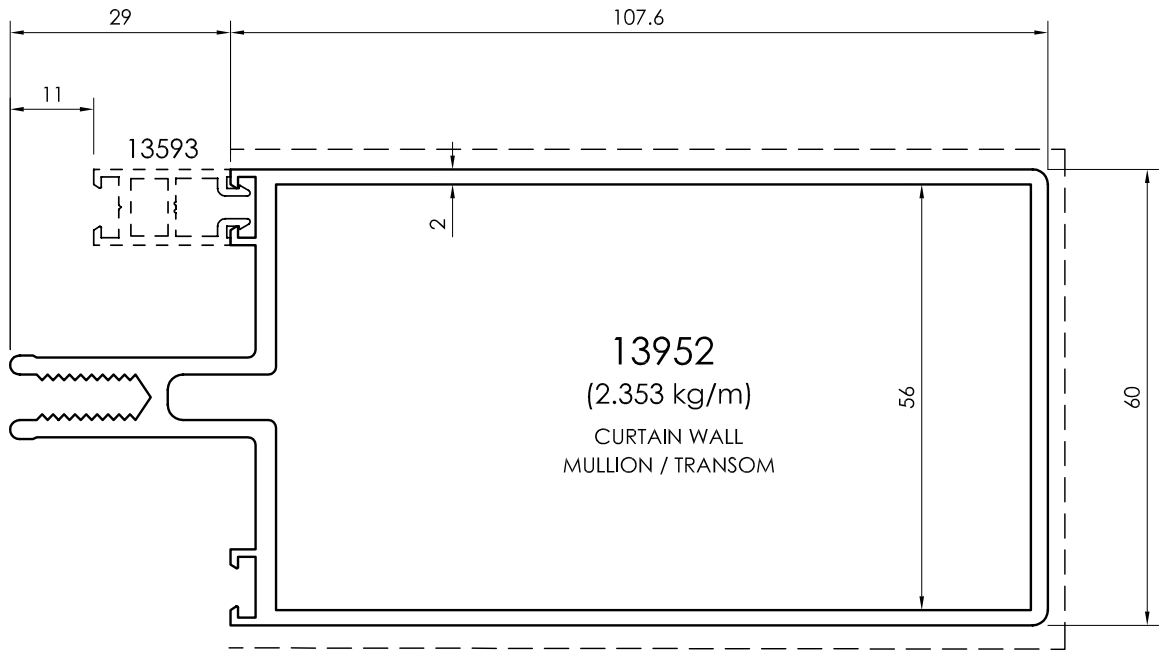

All dimensions in mm
----- Visible area

Mullion / Transom Profiles

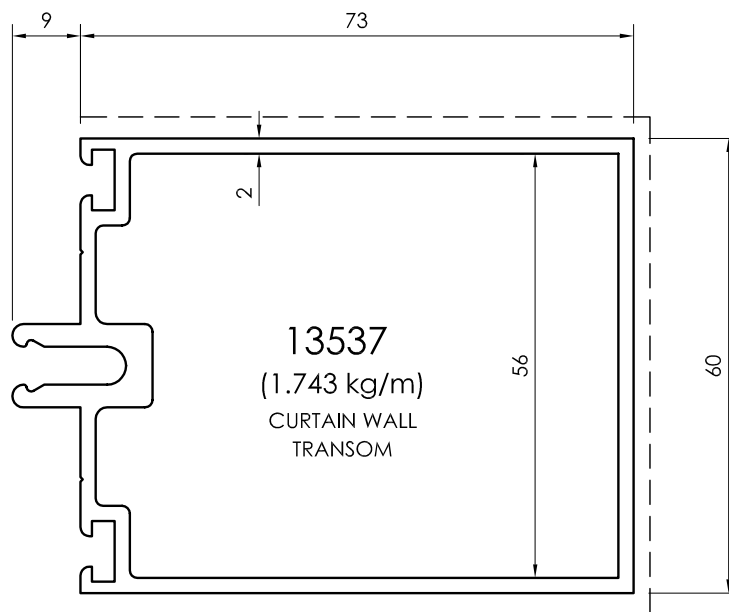
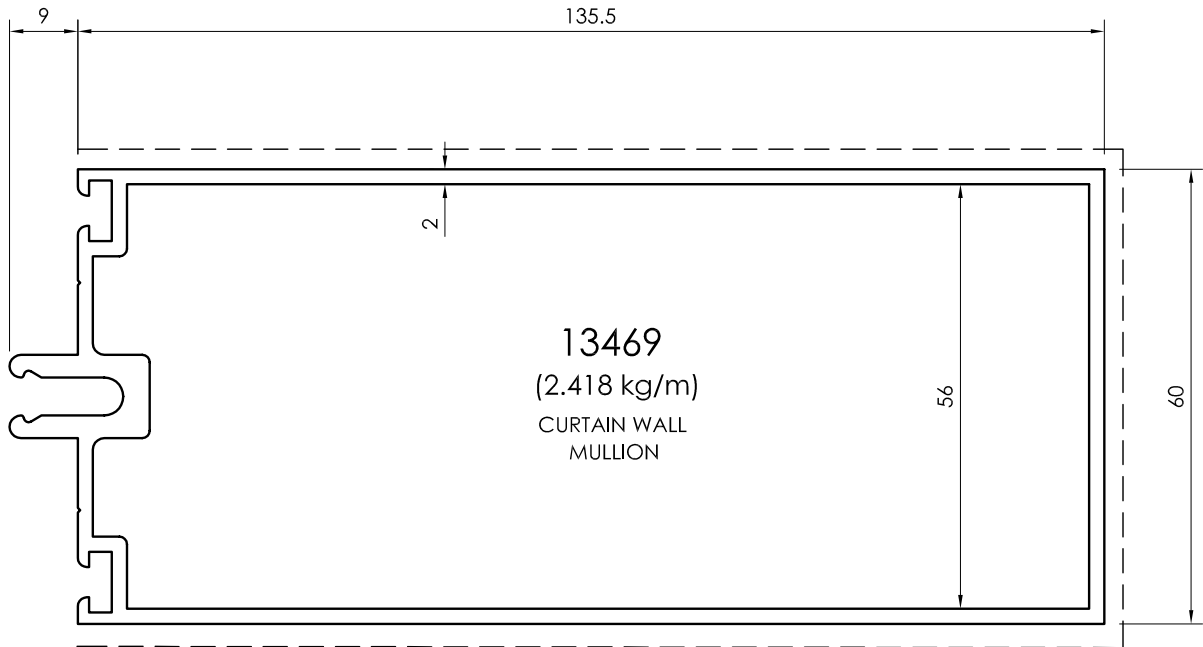

All dimensions in mm
Visible area_____

Mullion / Transom Profiles

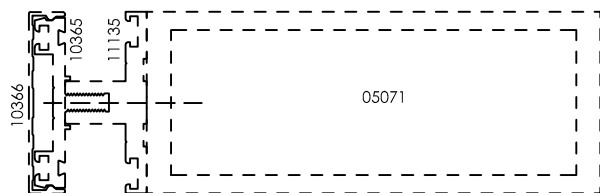
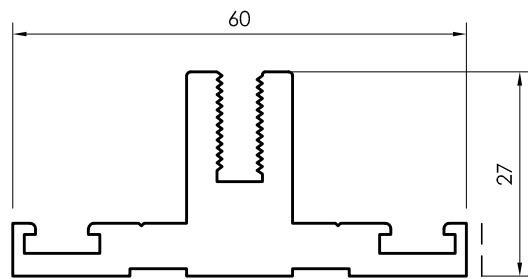
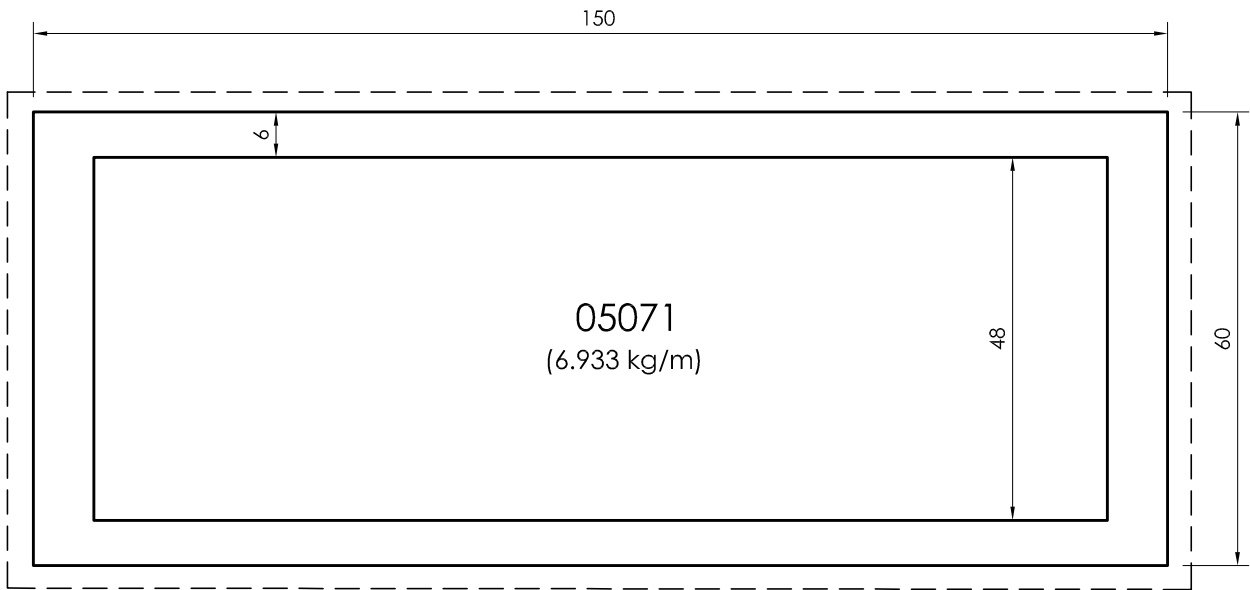
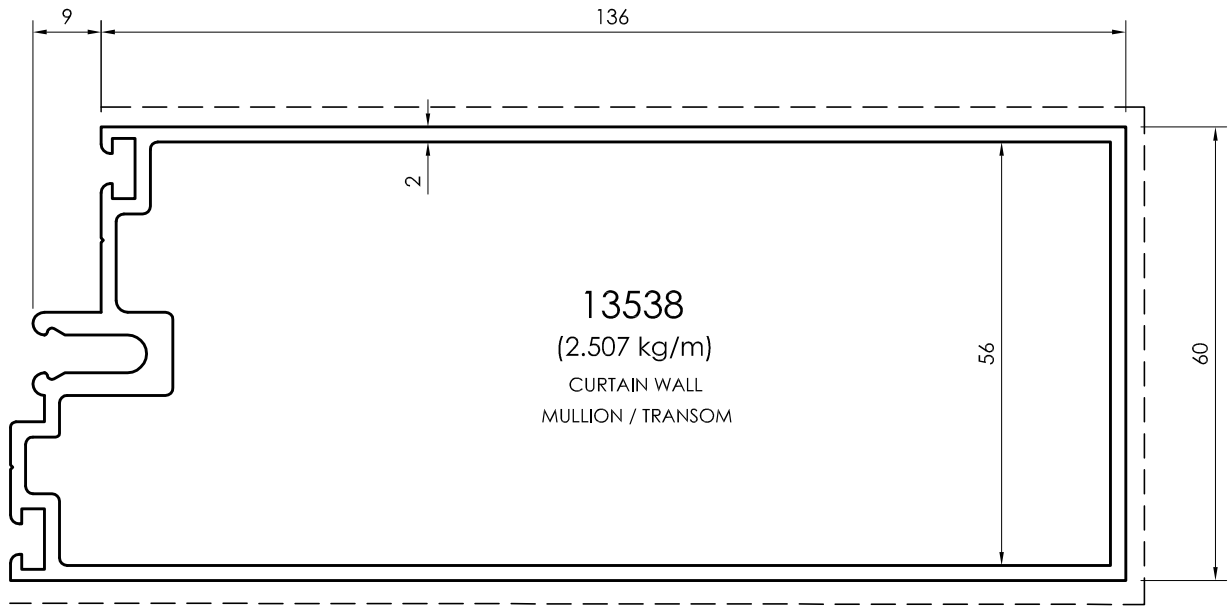

All dimensions in mm
----- Visible area

Frame / Sash Profiles

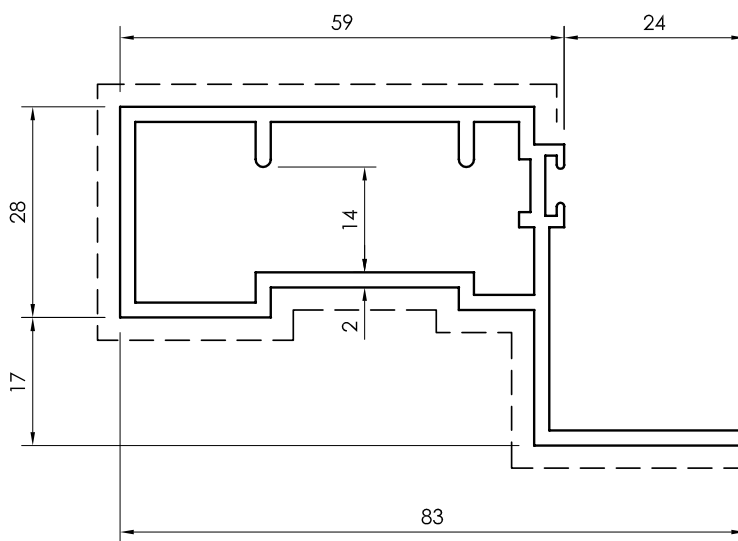
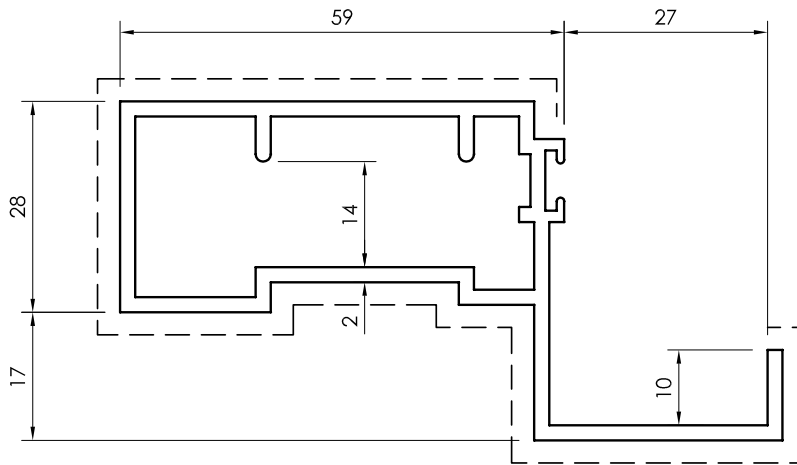
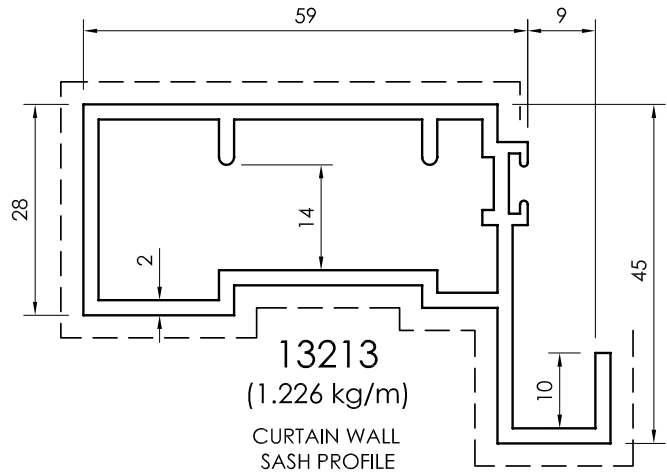
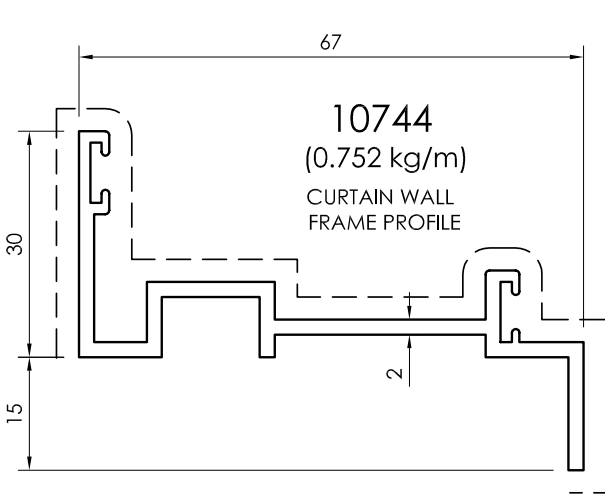

All dimensions in mm
Visible area_____

Frame / Sash Profiles

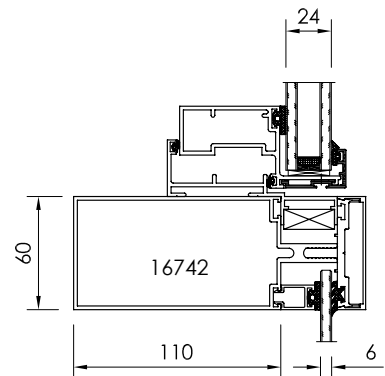
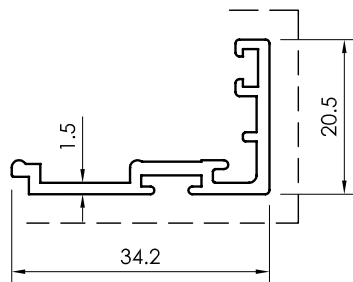
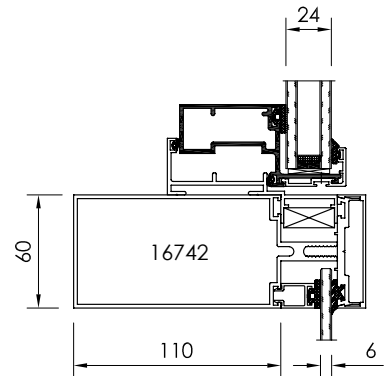
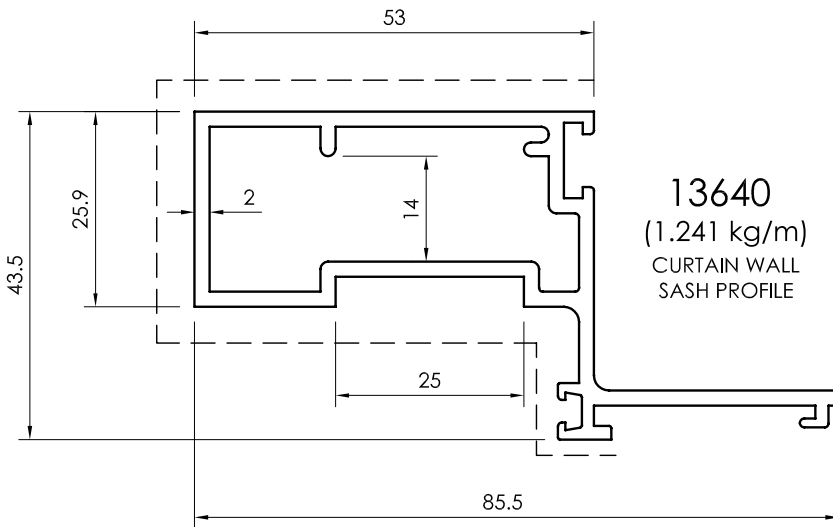
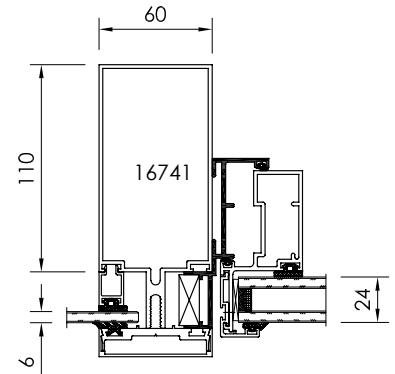
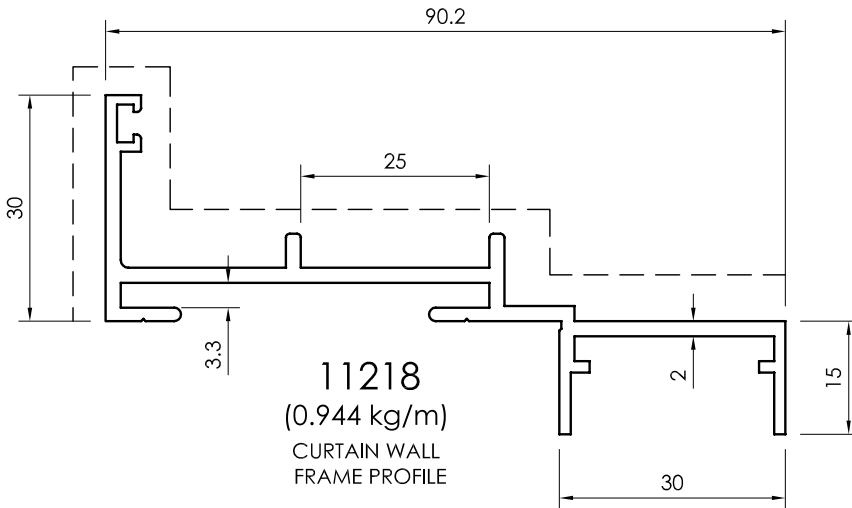

All dimensions in mm
----- Visible area

Frame / Sash Profiles

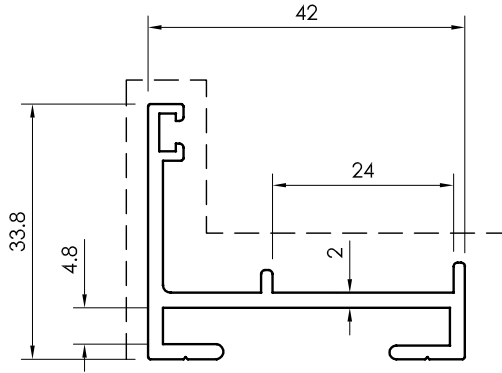

22405
(0.560 kg/m)
CURTAIN WALL
FRAME PROFILE

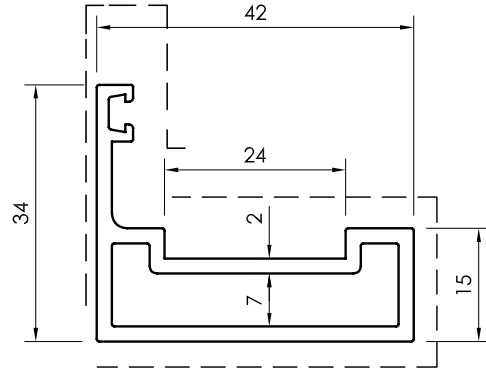

15907
(0.740 kg/m)
CURTAIN WALL
SASH PROFILE

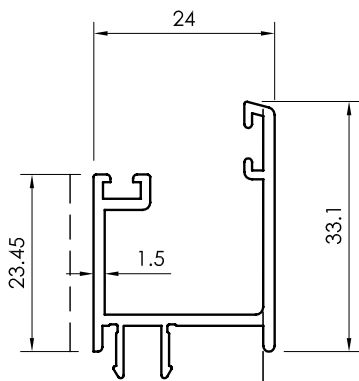

24373
(0.407 kg/m)
GLAZING CLIP

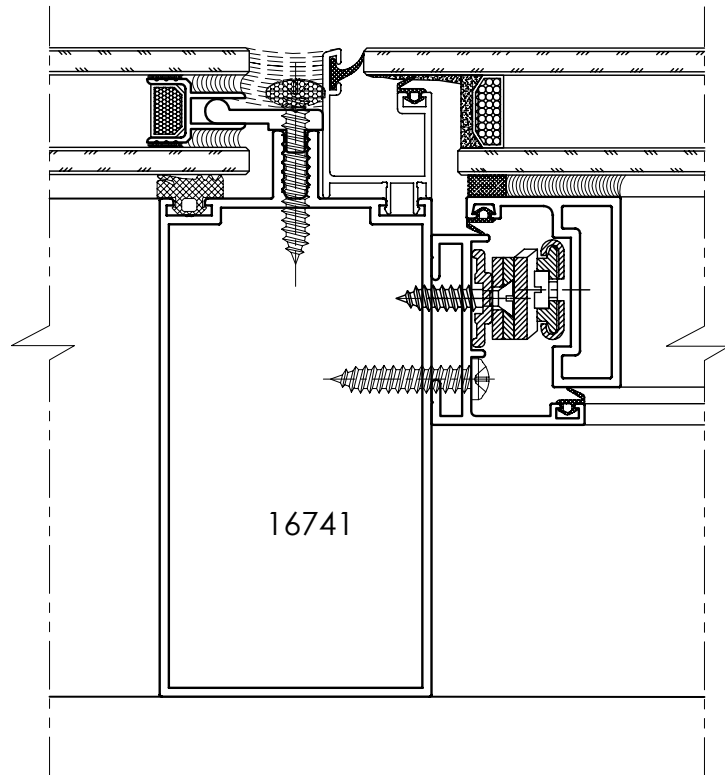

16741

All dimensions in mm
Visible area_____

Frame / Sash Profiles

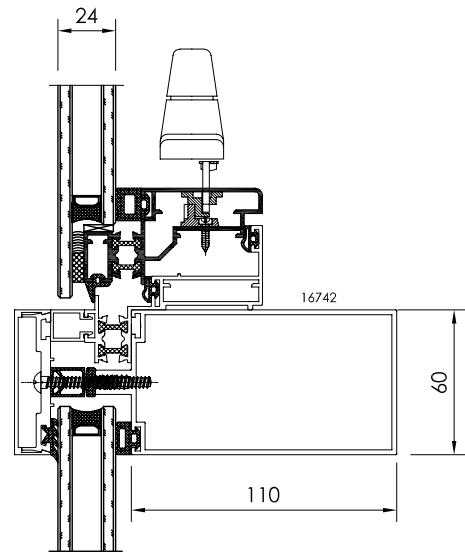
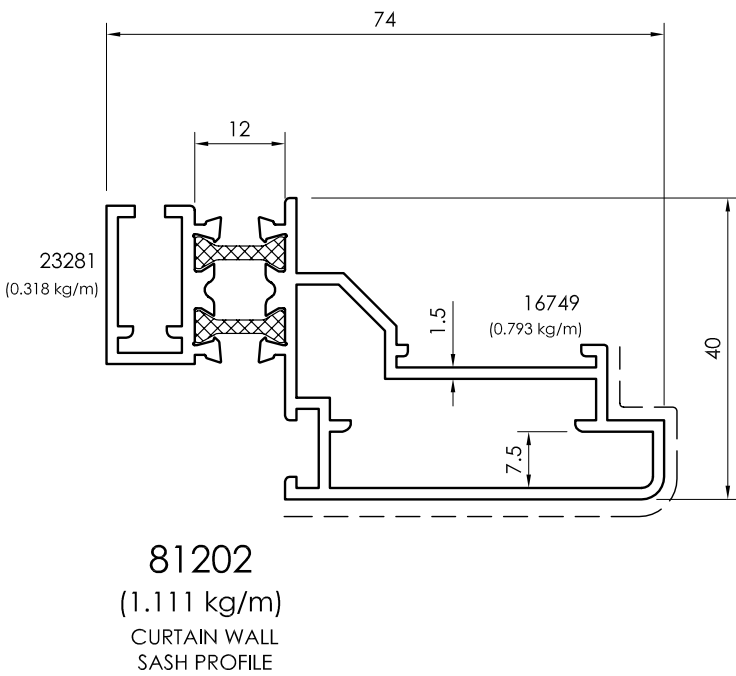
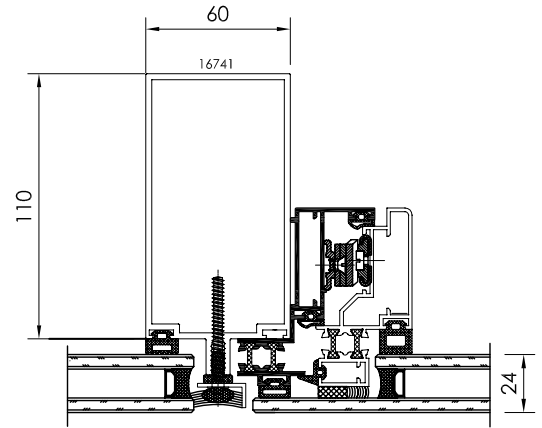
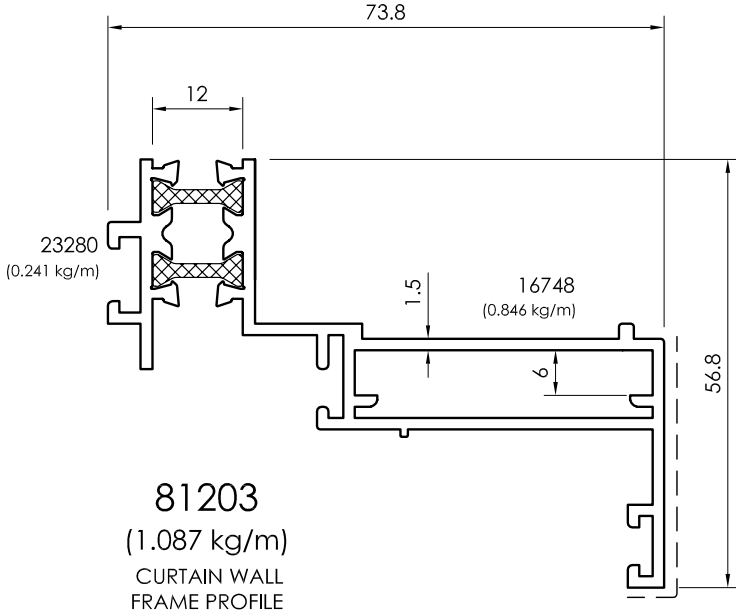

All dimensions in mm
----- Visible area

Frame / Sash Profiles

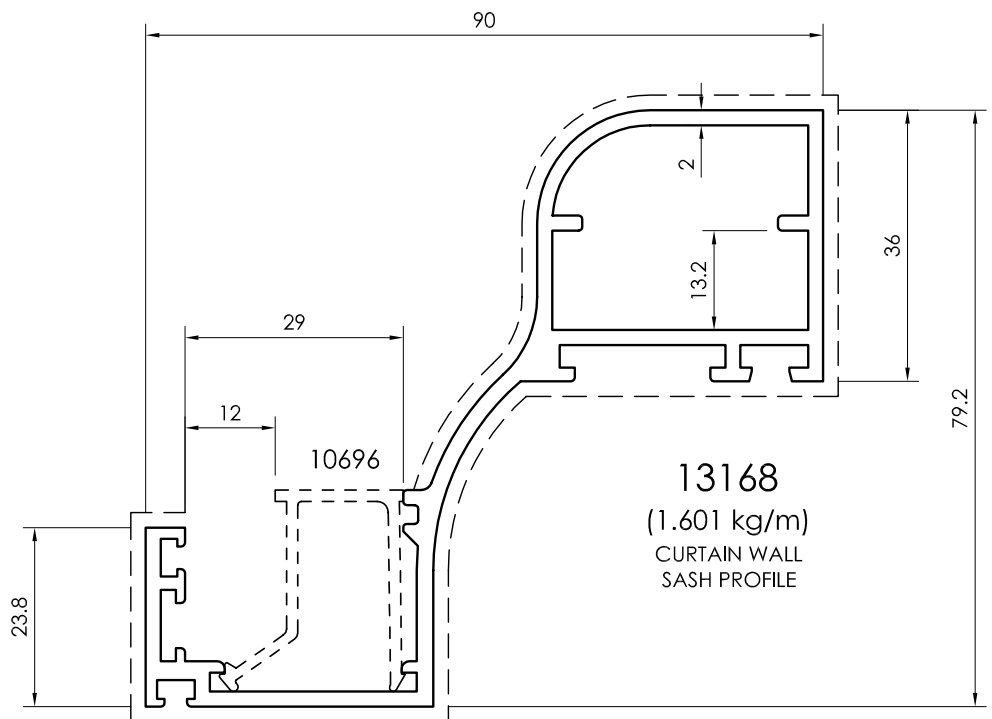
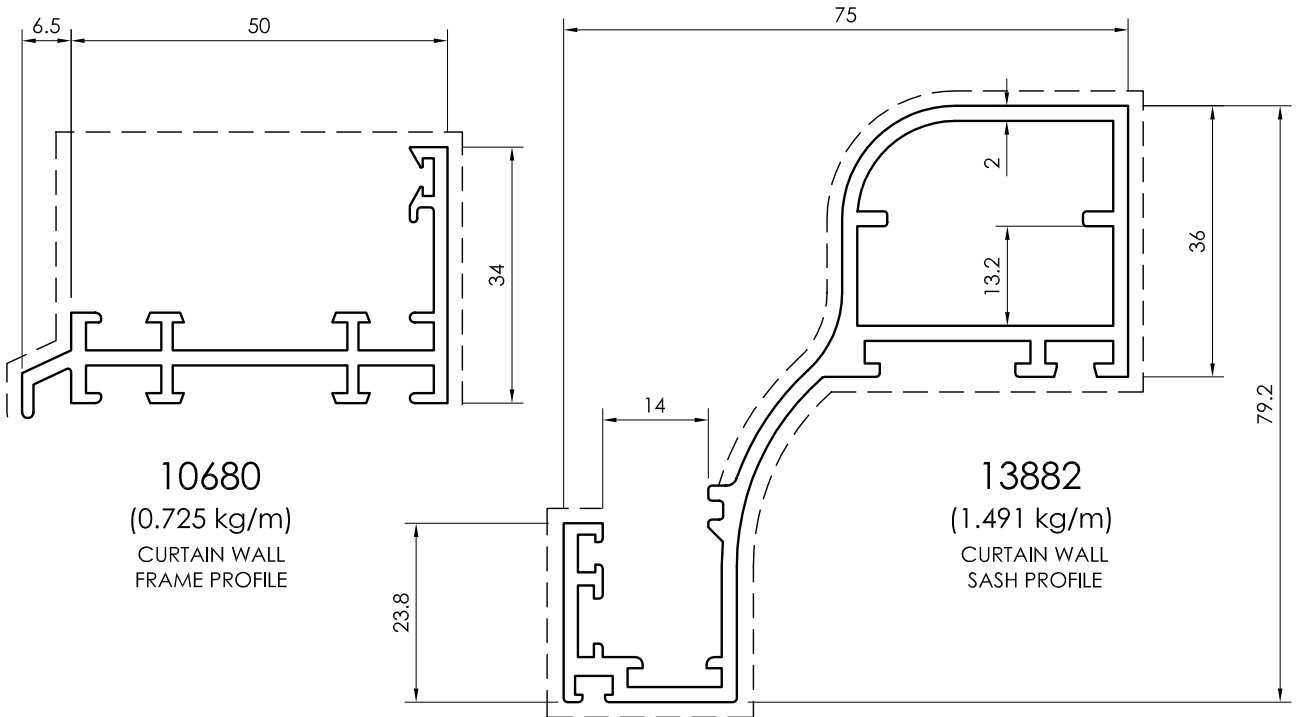

All dimensions in mm
Visible area_____

Complementary Profiles

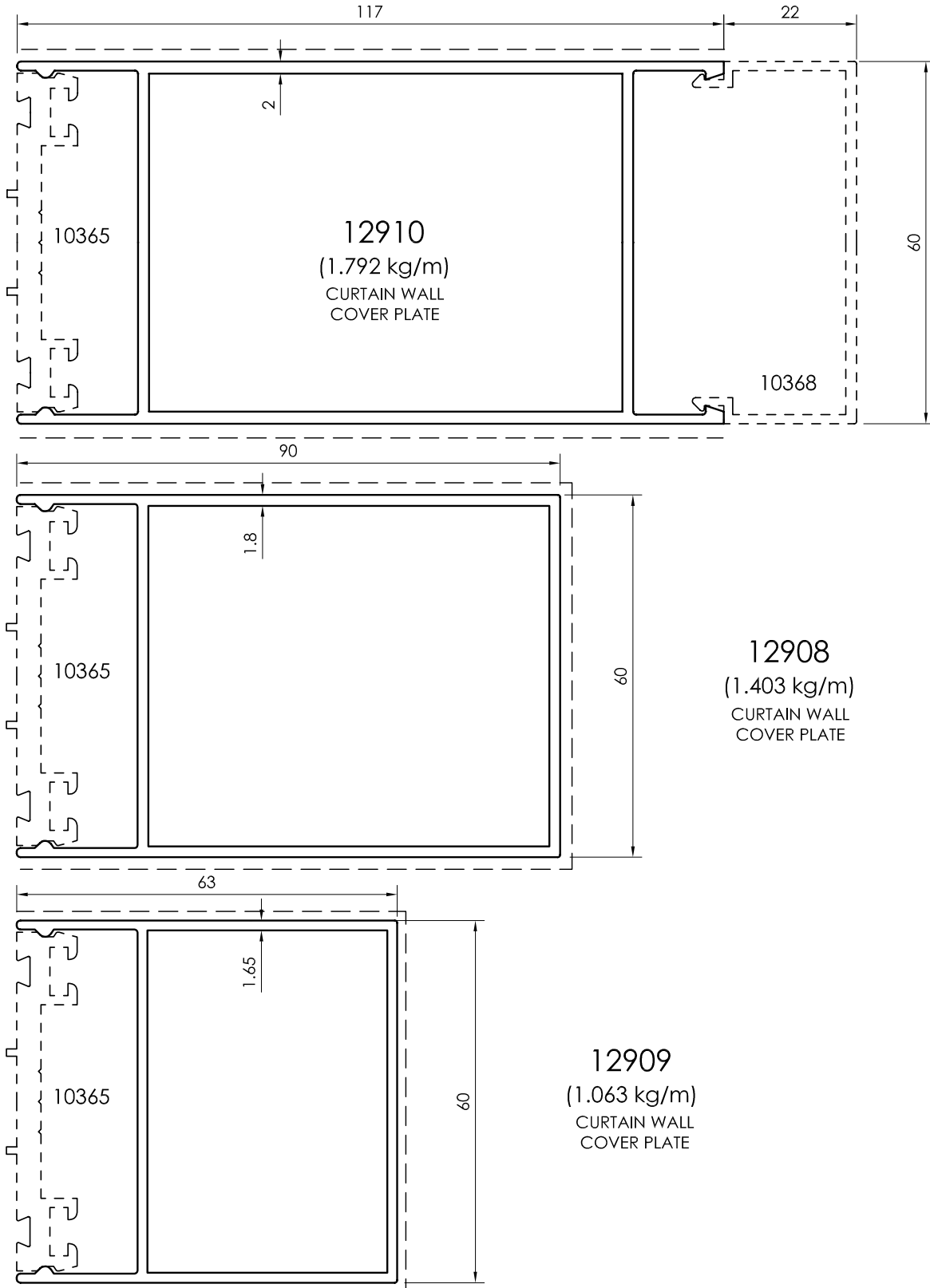

All dimensions in mm
 - - - - - Visible area

Complementary Profiles

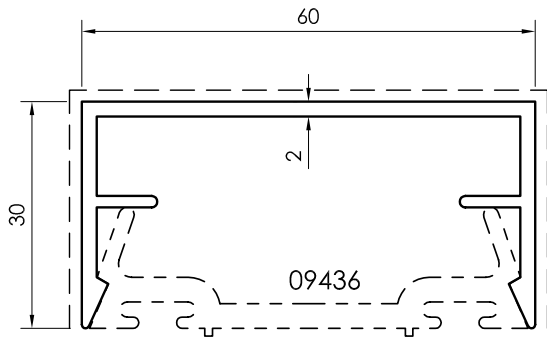

09437
(0.705 kg/m)
CURTAIN WALL
COVER PLATE

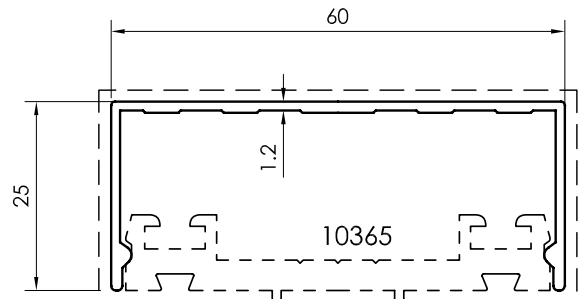

10809
(0.394 kg/m)
CURTAIN WALL
COVER PLATE

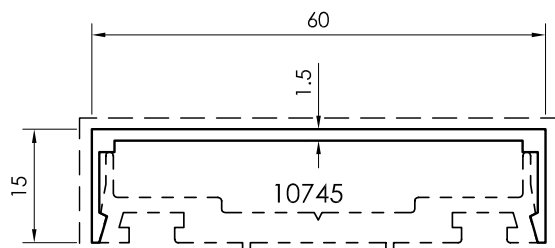

10746
(0.370 kg/m)
CURTAIN WALL
COVER PLATE

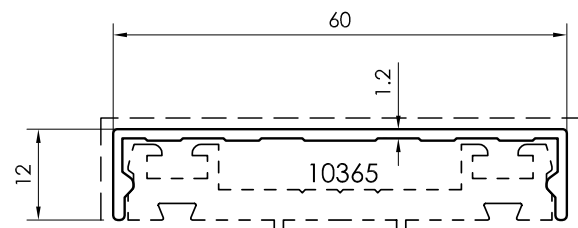

10366
(0.310 kg/m)
CURTAIN WALL
COVER PLATE

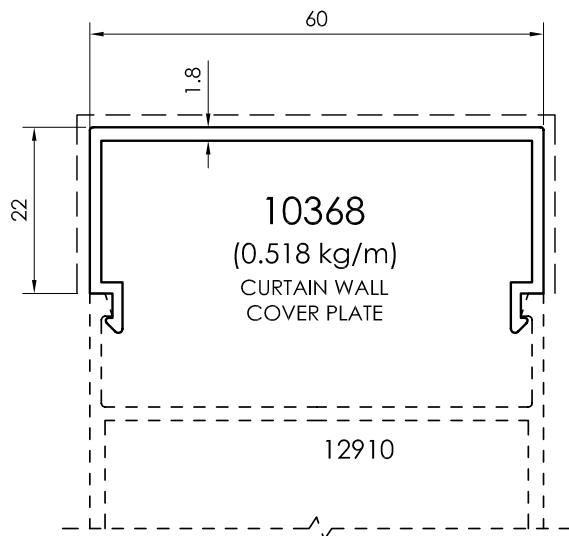

10368
(0.518 kg/m)
CURTAIN WALL
COVER PLATE

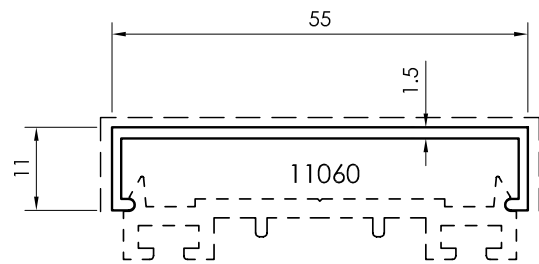

11061
(0.298 kg/m)
CURTAIN WALL
COVER PLATE

All dimensions in mm
Visible area_____

Complementary Profiles

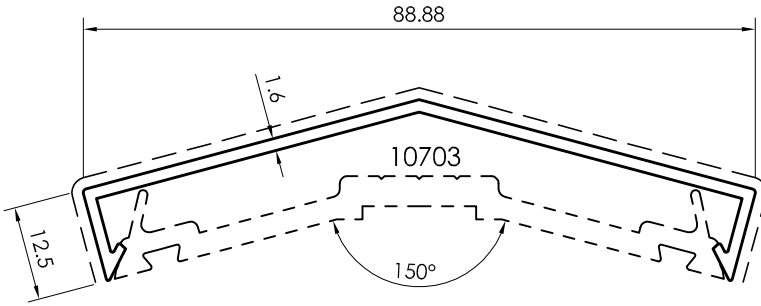

10704
(0.497 kg/m)
CURTAIN WALL
COVER PLATE

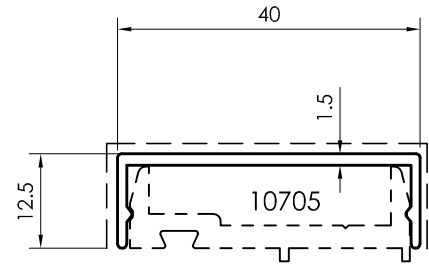

10706
(0.237 kg/m)
CURTAIN WALL
COVER PLATE

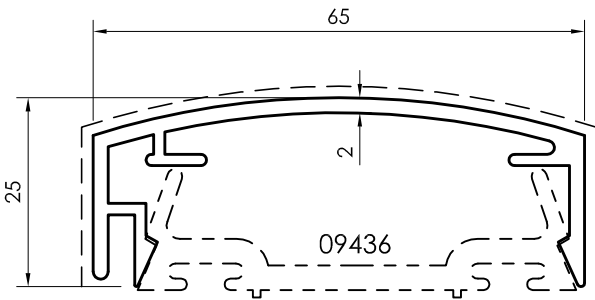

09438
(0.700 kg/m)
CURTAIN WALL
COVER PLATE

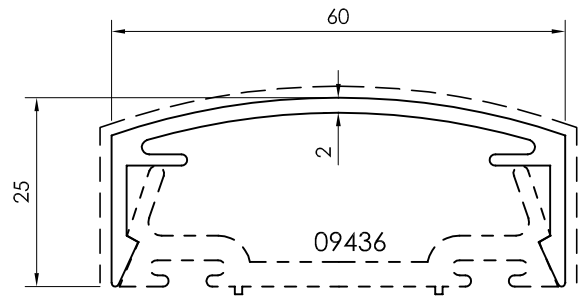

09439
(0.617 kg/m)
CURTAIN WALL
COVER PLATE

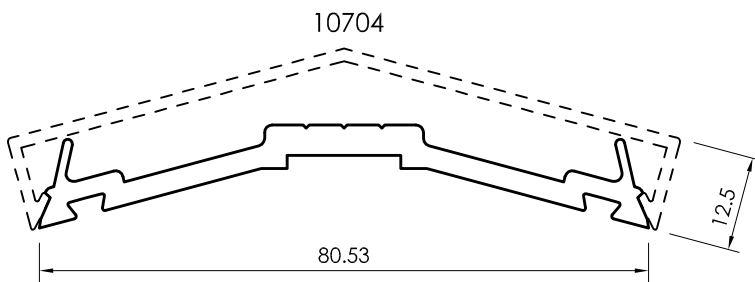

10703
(0.832 kg/m)
CURTAIN WALL
PRESSURE PLATE

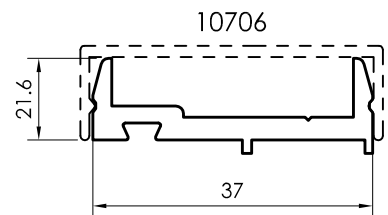

10705
(0.406 kg/m)
CURTAIN WALL
PRESSURE PLATE

All dimensions in mm
----- Visible area

Complementary Profiles

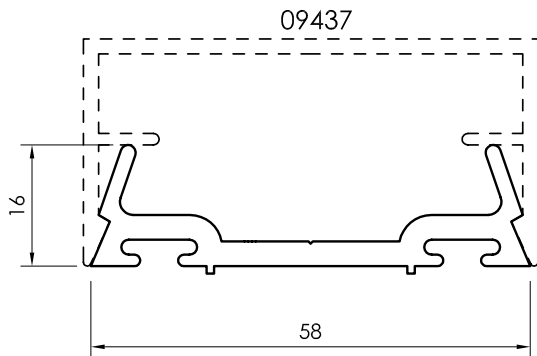

09436
(0.756 kg/m)
CURTAIN WALL
PRESSURE PLATE

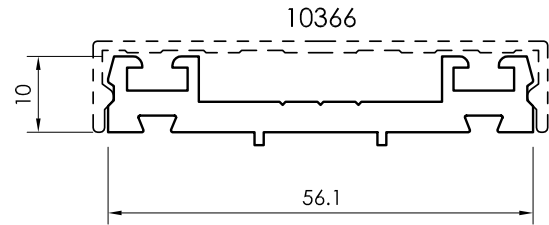

10365
(0.771 kg/m)
CURTAIN WALL
PRESSURE PLATE

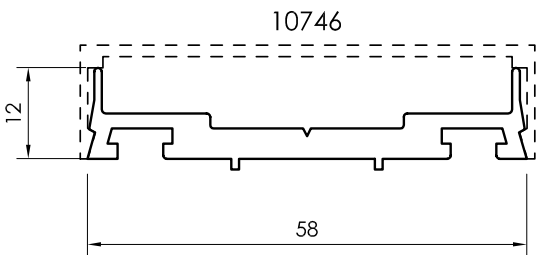

10745
(0.605 kg/m)
CURTAIN WALL
PRESSURE PLATE

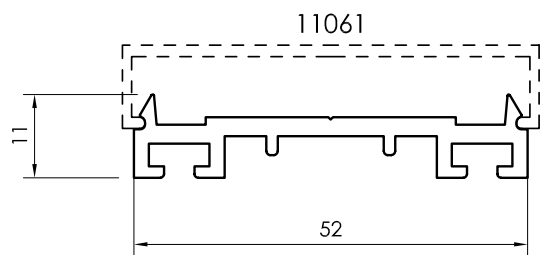

11060
(0.537 kg/m)
CURTAIN WALL
PRESSURE PLATE

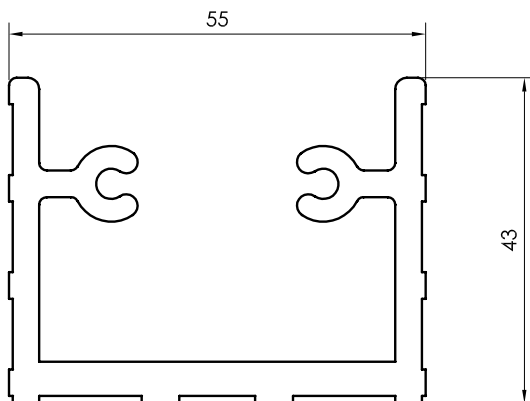

10164
(1.820 kg/m)
CURTAIN WALL
CONNECTOR

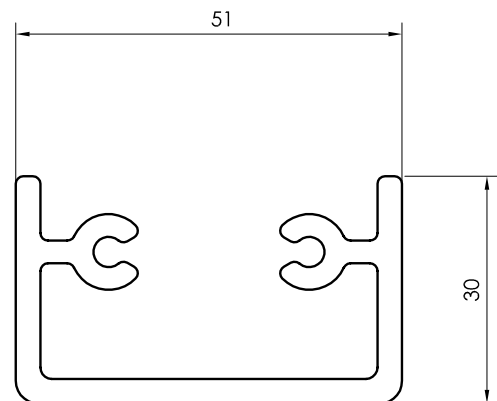

11184
(1.268 kg/m)
CURTAIN WALL
CONNECTOR

All dimensions in mm
Visible area_____

Complementary Profiles

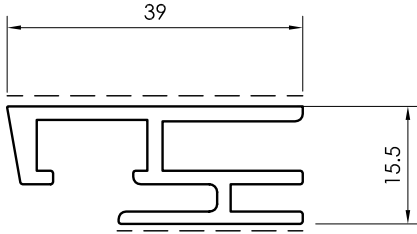

11956
(0.541 kg/m)
GLASS SPACER

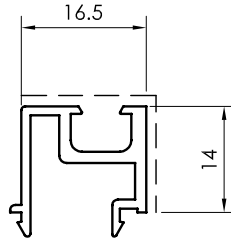

11059
0.229 kg/m
CLIP PROFILE

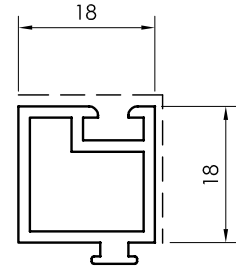

13279
(0.334 kg/m)
CLIP PROFILE

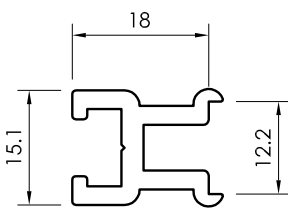

11472
(0.365 kg/m)
ADAPTOR PROFILE

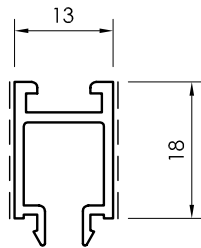

10529
(0.213 kg/m)
CLIP PROFILE

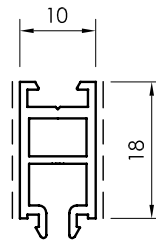

13953
(0.201 kg/m)
CLIP PROFILE

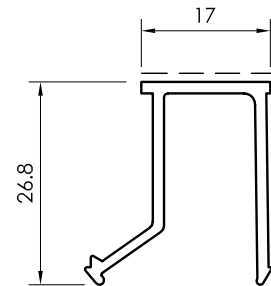

10696
(0.290 kg/m)
GLAZING BEAD

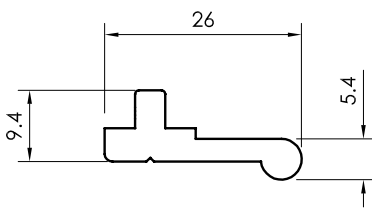

21074
(0.331 kg/m)
GLASS TOGGLER

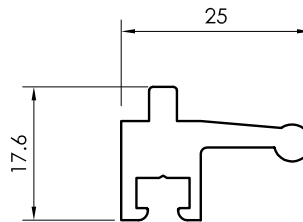

11434
(0.454 kg/m)
GLASS TOGGLER

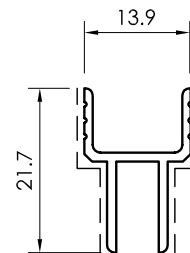

21073
(0.167 kg/m)
GLASS SPACER

All dimensions in mm
----- Visible area

Complementary Profiles

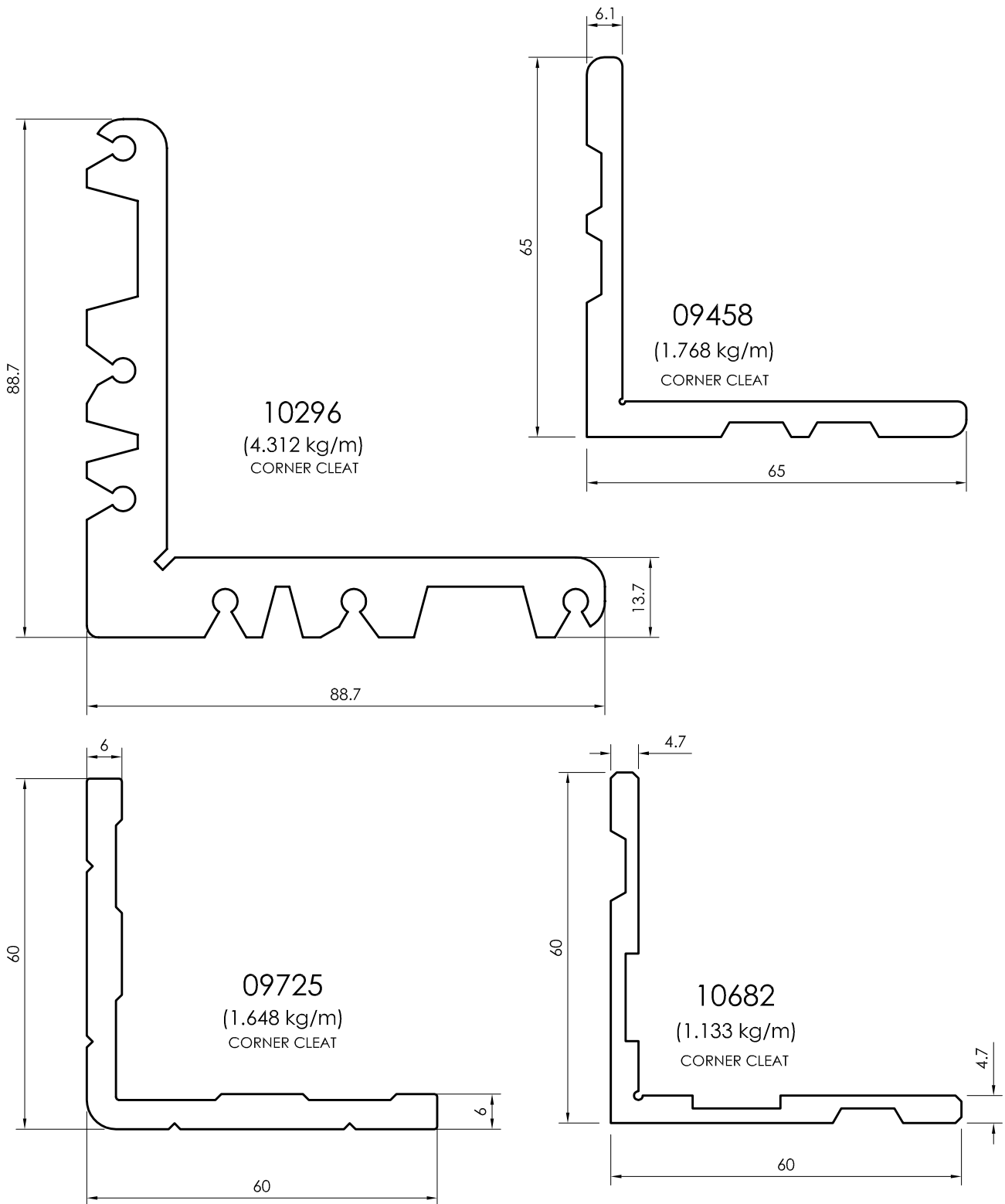





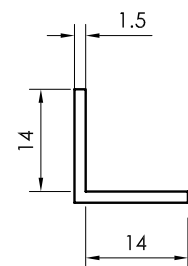
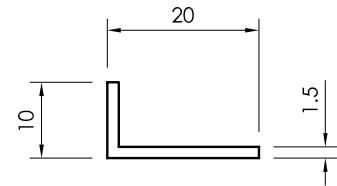
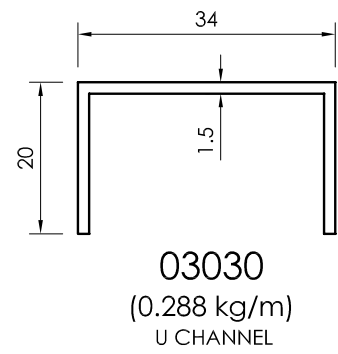
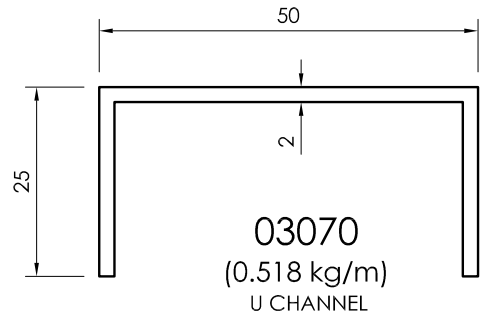
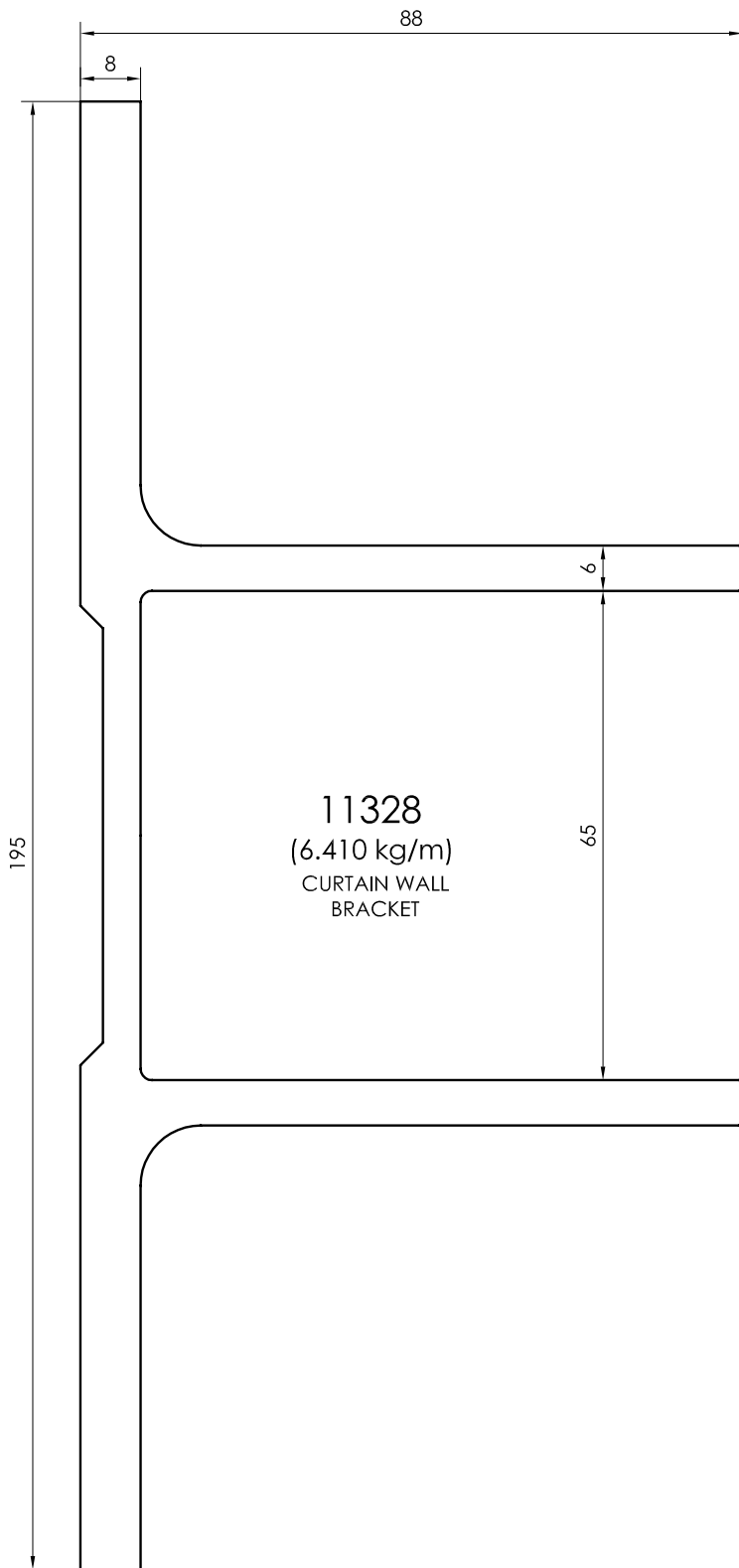

All dimensions in mm
Visible area_____





Complementary Profiles

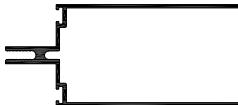







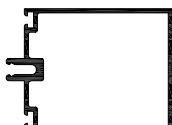
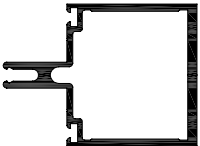
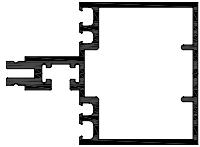

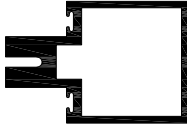
All dimensions in mm
----- Visible area

PROFILE LIST

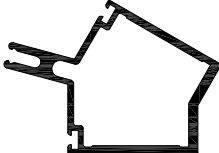

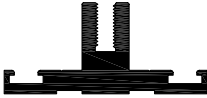
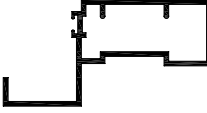

Profile Reference	Child Profile	Profile Section	Page	Weight KG/M	IX cm ⁴	IY cm ⁴	WX cm ³	WY cm ³
13278	--		19	4.248	91.619	648.512	30.540	63.908
13474	--		18	2.349	46.660	199.991	15.553	27.398
13322	--		18	3.262	65.297	273.536	21.766	34.458
13952	--		21	2.353	43.642	172.951	14.547	25.110
13495	--		14	2.296	43.759	177.094	14.588	25.189
13214	--		14	3.834	67.560	309.237	22.520	43.481
14600	--		15	2.432	47.613	183.233	15.871	25.719

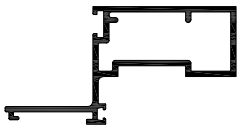
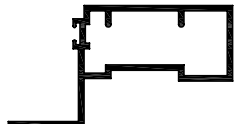
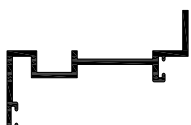

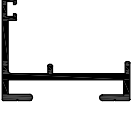
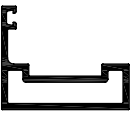
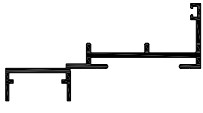
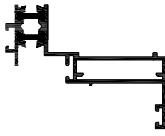
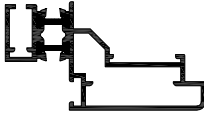
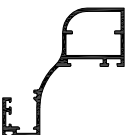
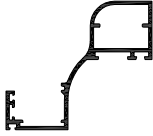

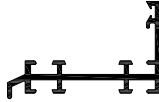
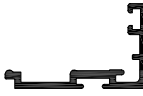
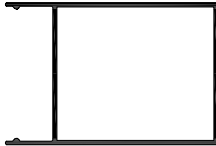
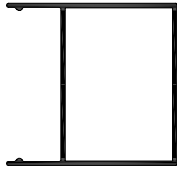

Profile Reference	Child Profile	Profile Section	Page	Weight KG/M	IX cm ⁴	IY cm ⁴	WX cm ³	WY cm ³
13951	--		15	2.836	50.464	202.462	16.821	26.628
16741	--		17	2.476	52.974	163.512	17.656	25.487
16742	--		17	2.041	43.612	137.988	14.535	21.954
13469	--		22	2.418	52.583	229.258	17.528	29.751
13537	--		22	1.743	31.597	53.177	10.532	12.307
12907	--		20	2.249	56.755	34.809	11.674	11.603
13525	--		21	1.956	25.274	44.942	8.374	10.478







Profile Reference	Child Profile	Profile Section	Page	Weight KG/M	IX cm ⁴	IY cm ⁴	WX cm ³	WY cm ³
12227	--		16	4.518	74.094	384.837	24.698	46.841
12226	--		16	3.710	46.326	111.247	15.442	22.242
13539	--		19	2.467	51.426	236.909	16.129	30.332
13538	--		23	2.507	54.673	250.608	17.725	31.283
13869	--		13	3.196	66.738	214.924	22.246	27.715
13250	--		13	2.370	46.658	175.088	15.553	23.999
13152	--		20	2.120	28.866	54.271	8.028	11.081





Profile Reference	Child Profile	Profile Section	Page	Weight KG/M	IX cm ⁴	IY cm ⁴	WX cm ³	WY cm ³
05071	--		23	6.933	146.506	725.058	48.835	96.674
11135	--		23	1.445	2.850	8.855	1.508	2.286
13212	--		24	1.323	11.099	31.249	4.390	6.416
13213	--		24	1.226	8.808	21.986	3.238	6.230
13640	--		25	1.241	8.933	24.499	3.643	5.023
13913	--		24	1.242	9.744	24.125	3.663	5.157
10744	--		24	0.752	1.944	16.515	0.809	4.489





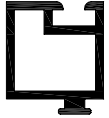
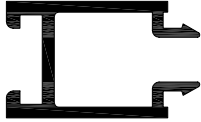
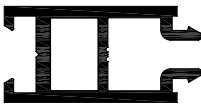

Profile Reference	Child Profile	Profile Section	Page	Weight KG/M	IX cm ⁴	IY cm ⁴	WX cm ³	WY cm ³
22405	--		26	0.560	4.926	1.563	1.895	0.665
15907	--		26	0.740	5.962	2.059	2.451	0.859
11218	--		25	0.944	2.530	30.965	0.981	6.147
81203	23280 + 16748		27	1.087	6.748	25.253	2.104	2.502
81202	23281 + 16749		27	1.111	5.567	19.415	2.532	2.171
13882	--		28	1.491	34.302	31.829	8.224	8.123
13168	--		28	1.601	39.545	47.213	9.905	9.507





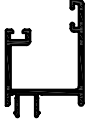

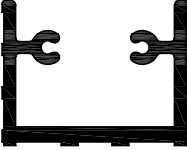
Profile Reference	Child Profile	Profile Section	Page	Weight KG/M	IX cm ⁴	IY cm ⁴	WX cm ³	WY cm ³
10680	--		28	0.725	1.878	10.019	0.761	2.956
11219	--		25	0.311	0.409	1.321	0.273	0.574
12908	--		29	1.403	45.759	32.227	9.273	10.742
12909	--		29	1.063	22.592	15.881	7.531	4.380
12910	--		29	1.792	42.705	80.463	14.235	13.466
09437	--		30	0.705	2.124	14.612	1.004	4.871
10809	--		30	0.394	0.966	7.961	0.528	2.654

Profile Reference	Child Profile	Profile Section	Page	Weight KG/M	IX cm ⁴	IY cm ⁴	WX cm ³	WY cm ³
10706	--		31	0.237	0.101	1.834	0.103	0.917
10746	--		30	0.370	0.199	5.849	0.163	1.950
10366	--		30	0.310	0.122	5.264	0.129	1.755
11061	--		30	0.298	0.105	4.049	0.121	1.472
10368	--		30	0.518	10.077	1.393	3.359	0.852
10704	--		31	0.497	0.628	16.111	0.425	3.625
09438	--		31	0.700	1.264	15.273	0.757	4.459

Profile Reference	Child Profile	Profile Section	Page	Weight KG/M	IX cm ⁴	IY cm ⁴	WX cm ³	WY cm ³
09439	--		31	0.617	1.038	11.882	0.602	3.961
10703	--		31	0.832	0.309	17.392	0.404	4.319
09436	--		32	0.756	0.345	9.539	0.291	3.289
10745	--		32	0.605	0.119	7.188	0.133	2.478
11060	--		32	0.537	0.103	5.605	0.181	2.156
10365	--		32	0.771	0.179	8.856	0.266	3.157
10705	--		31	0.406	0.088	2.284	0.108	1.231

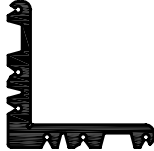





Profile Reference	Child Profile	Profile Section	Page	Weight KG/M	IX cm ⁴	IY cm ⁴	WX cm ³	WY cm ³
11956	--		33	0.541	0.572	2.583	0.649	1.244
11059	--		33	0.229	0.184	0.319	0.179	0.316
13279	--		33	0.334	0.576	0.483	0.527	0.510
10529	--		33	0.213	0.197	0.314	0.303	0.255
13953	--		33	0.201	0.101	0.248	0.201	0.224
10696	--		33	0.290	0.820	0.608	0.532	0.401
21073	--		33	0.167	0.130	0.187	0.185	0.170

Profile Reference	Child Profile	Profile Section	Page	Weight KG/M	IX cm ⁴	IY cm ⁴	WX cm ³	WY cm ³
21074	--		33	0.331	0.071	0.695	0.102	0.483
11472	--		33	0.365	0.371	0.337	0.349	0.435
24373	--		26	0.407	1.414	1.355	0.684	1.081
11434	--		33	0.454	0.234	0.776	0.249	0.483
10164	--		32	1.820	11.880	28.025	2.564	10.191
11184	--		32	1.268	4.082	16.519	2.316	6.478
11328	--		35	6.410	160.469	615.244	24.327	63.102

Profile Reference	Child Profile	Profile Section	Page	Weight KG/M	IX cm ⁴	IY cm ⁴	WX cm ³	WY cm ³
14699			12	3.370	432.953	66.556	48.962	22.185
14700			12	2.792	355.364	61.985	41.426	20.661
10296	--		34	4.312	--	--	--	--
09725	--		34	1.648	--	--	--	--
09458	--		34	1.768	--	--	--	--
10682	--		34	1.133	--	--	--	--

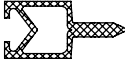
ACCESSORIES

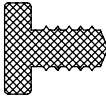
Gasket / Accessories Reference	Section	Description	Unit
GE-G-055		EPDM RUBBER USED WITH MULLION / TRANSOM	Linear Meter
GE-G-033		EPDM RUBBER USED WITH BRUSHER PLATTE & SASH 13913	Linear Meter
GE-G-034		EPDM RUBBER USED WITH SASH 13212	Linear Meter
GE-G-039		EPDM RUBBER USED WITH GLASS SPACER	Linear Meter
GE-CW-050		EPDM RUBBER USED WITH FRAME 81203	Linear Meter
GE-CW-03		EPDM RUBBER USED WITH SASH 81202	Linear Meter
GE-G-045		EPDM RUBBER USED WITH FRAME 81203	Linear Meter
GE-CW-043		EPDM RUBBER USED WITH SASH 81202	Linear Meter

Gasket / Accessories Reference	Section	Description	Unit
GE-G-041		EPDM RUBBER USED WITH GLASS SPACER	Linear Meter
GE-G-047		EPDM RUBBER USED WITH FRAME 10744	Linear Meter
GE-I-01		THERMAL STRP	Linear Meter
GE-G-060		EPDM RUBBER FOR TRANSOM COVER CLIP	Linear Meter
GE-G-015		EPDM RUBBER USED WITH FRAME & SASH	Linear Meter
GE-I-02		STRIP THERMAL	Linear Meter
GE-STAY ARM		FRICTION STAY ARM	Piece
GE-LOCKING SYSTEM		LOCKING SYSTEM	Piece

ASSEMBLY DRAWINGS

60mm 4-way Structural Glazing
Detail - 1

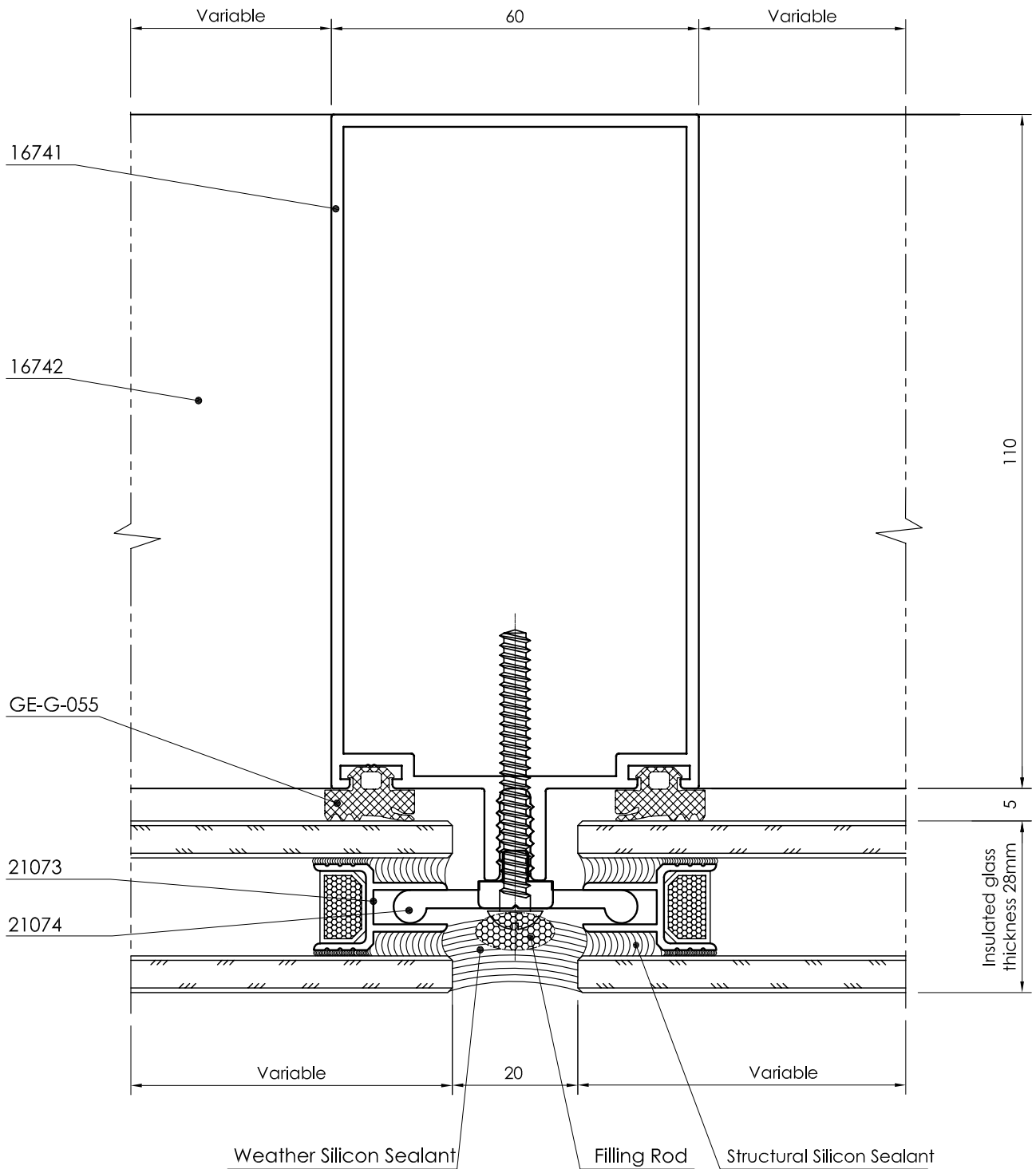

All dimensions in mm
----- Visible area

60mm 4-way Structural Glazing
Detail - 2

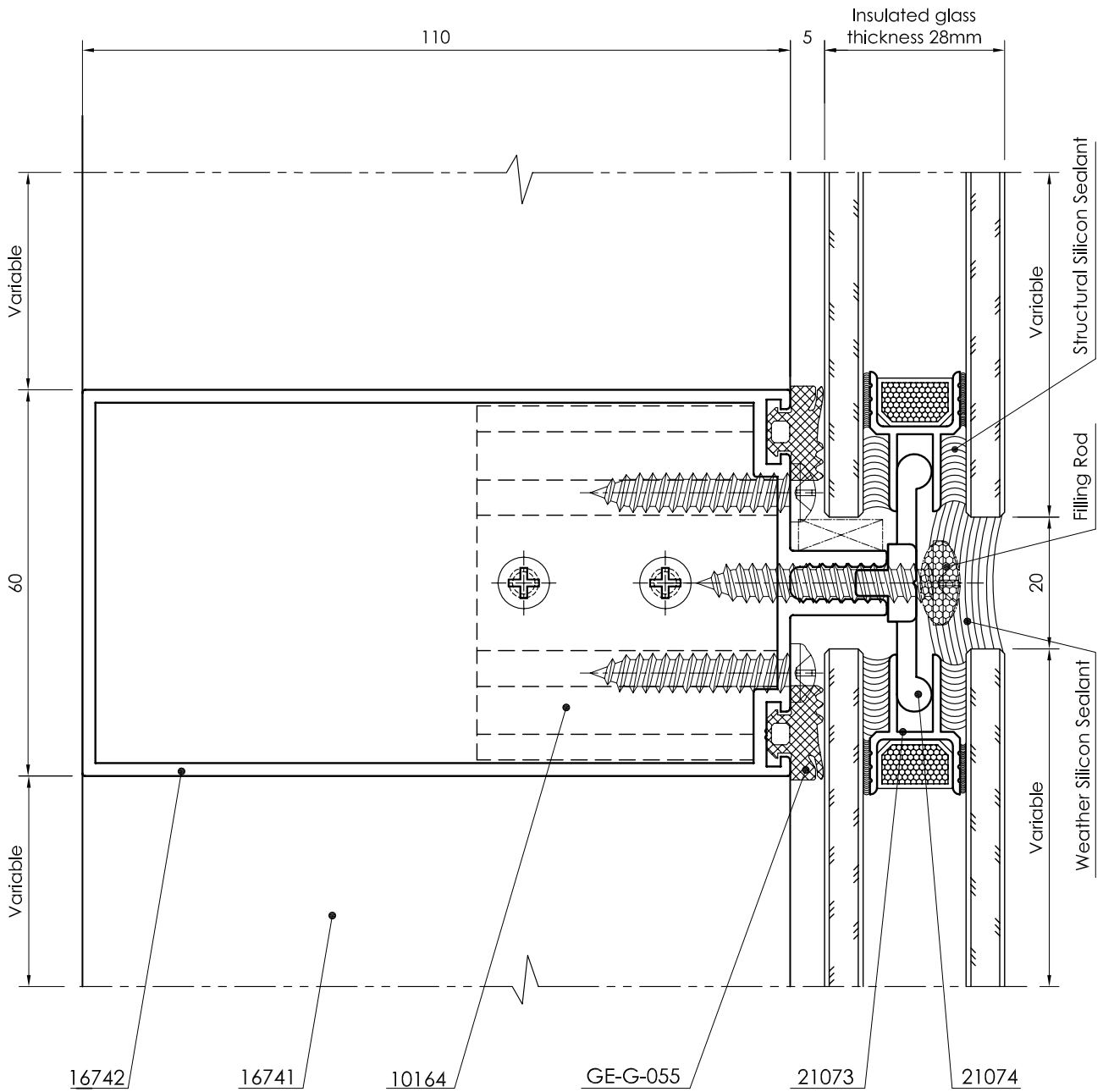

All dimensions in mm
Visible area_____

60mm 4-way Structural Glazing
Detail - 3

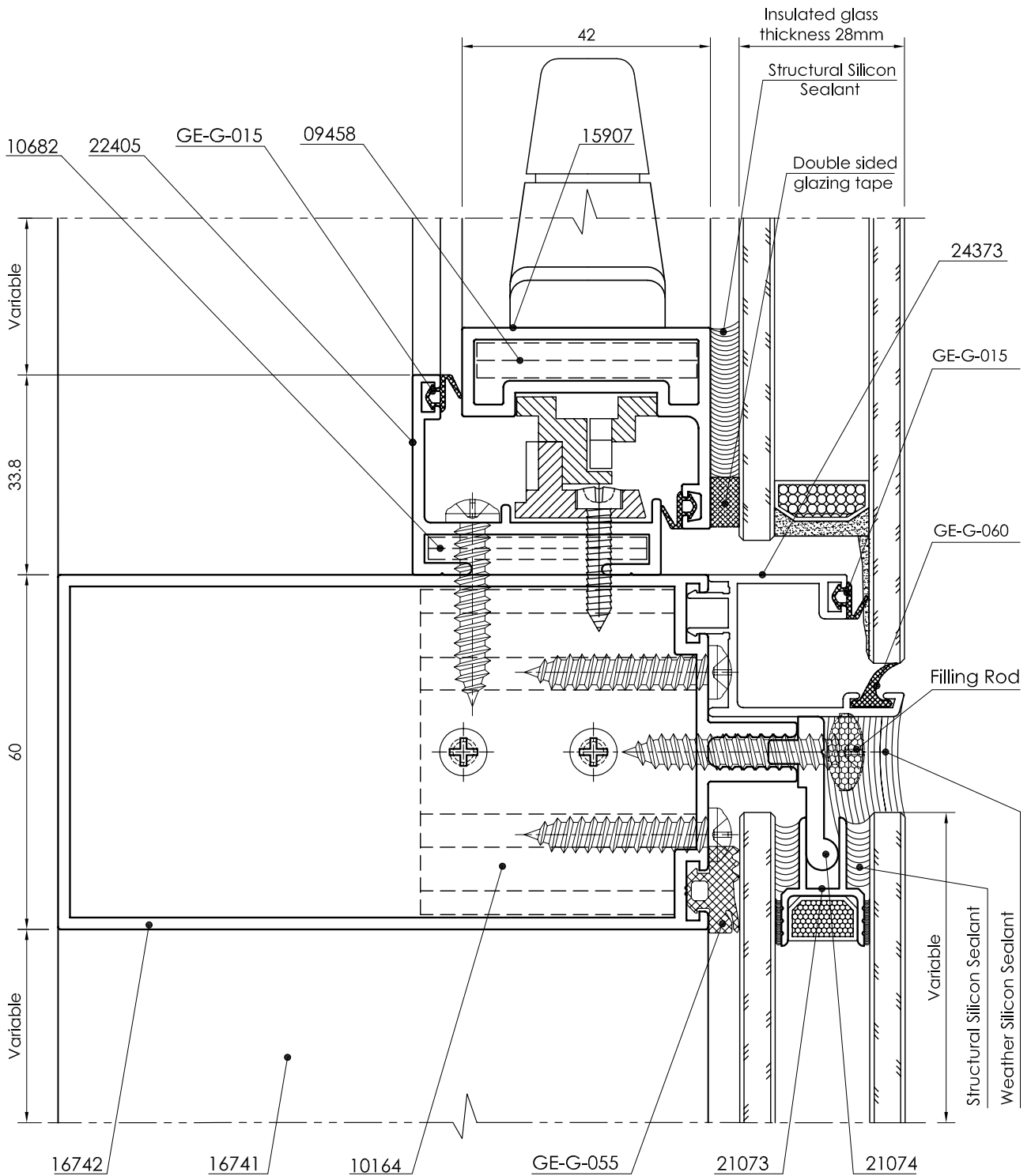

All dimensions in mm
----- Visible area

60mm 4-way Structural Glazing
Detail - 4

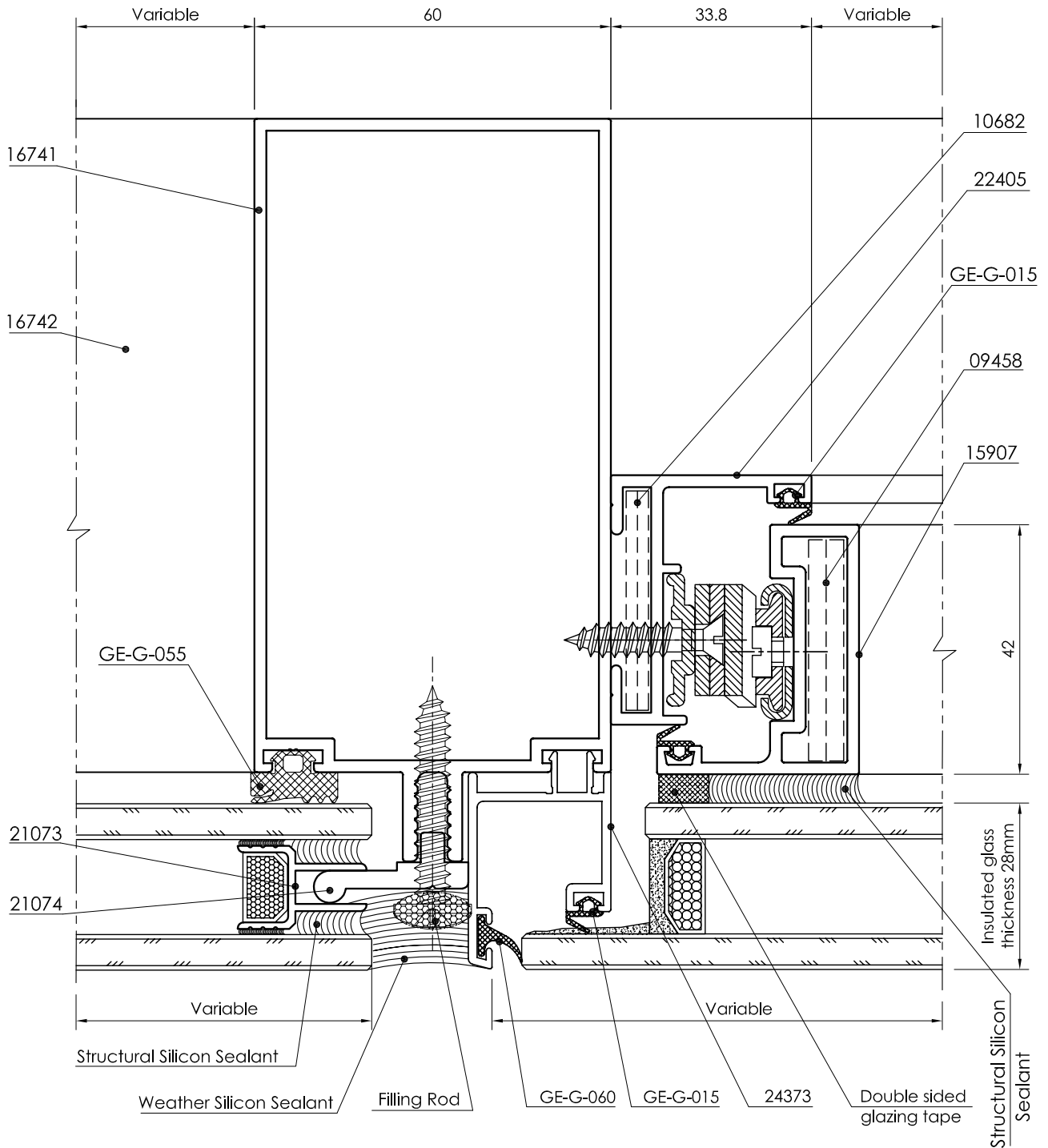

All dimensions in mm
Visible area_____

60mm 4-way Structural Glazing
Detail - 5

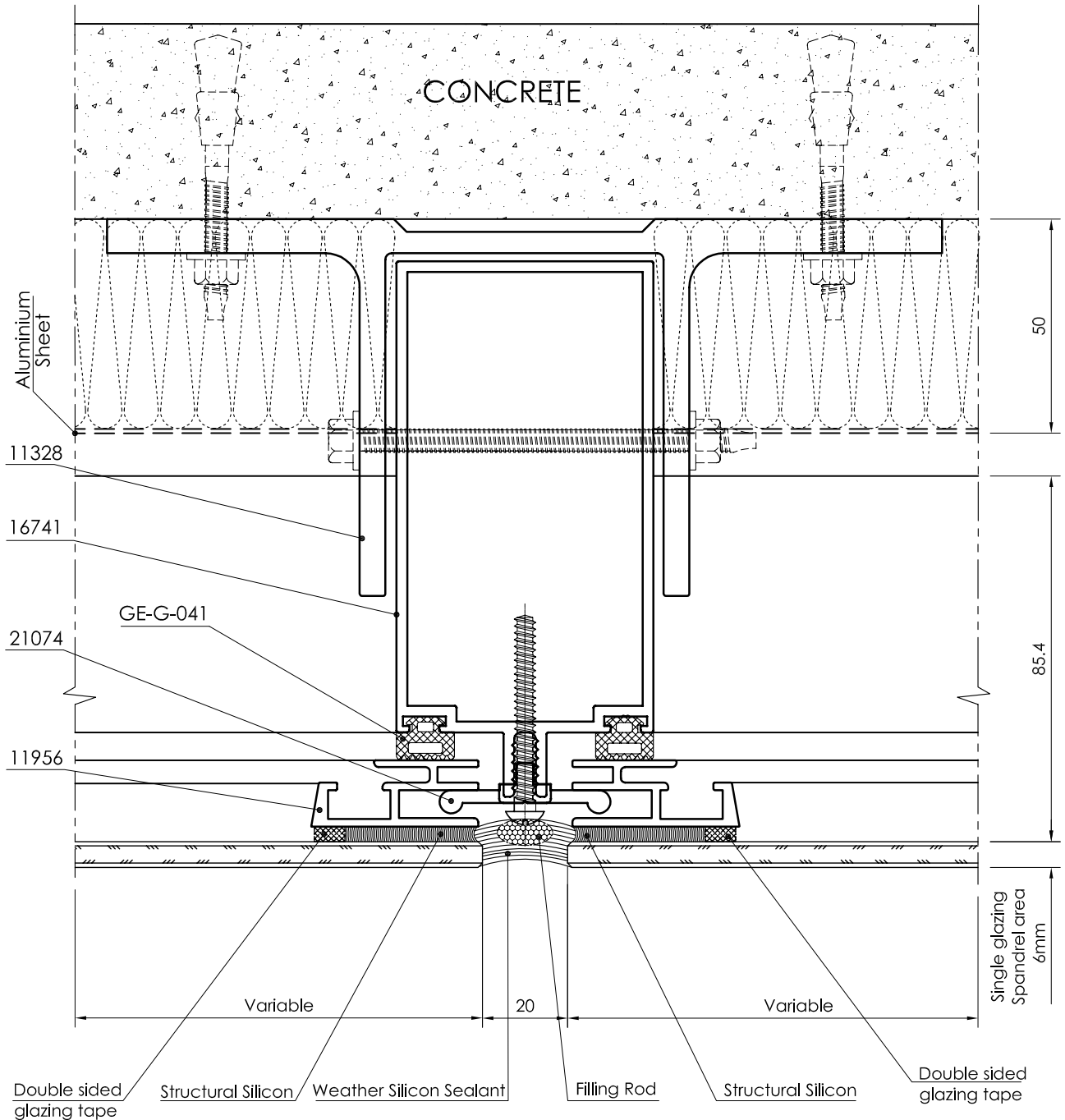

All dimensions in mm
----- Visible area

60mm 4-way Structural Glazing
Detail - 6

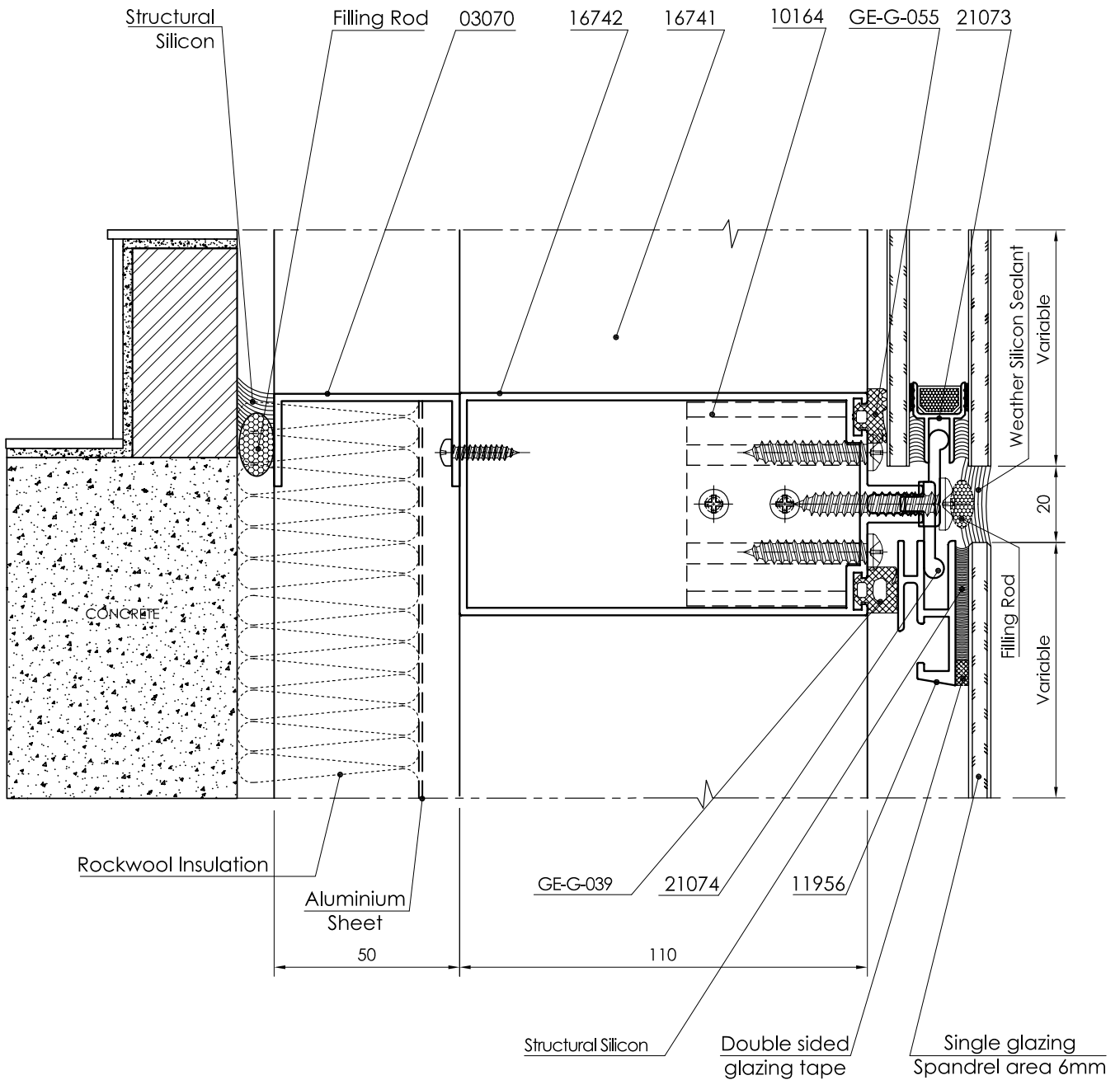

All dimensions in mm
Visible area_____

60mm 4-way Structural Glazing

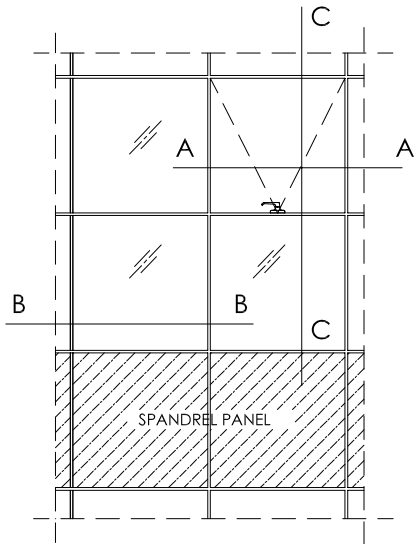

Profiles		
Description	Shape	Section No.
Curtain wall		16741 / 16742
Frame		22405
Sash		15907
Connector		10164
Corner cleat		09458
Corner cleat		10682
Glass spacer		21073
Glass Toggler		21074
Glass spacer		11956
Bracket		11328
U-Channel		03070
Glazing clip		24373

DETAIL : C-C

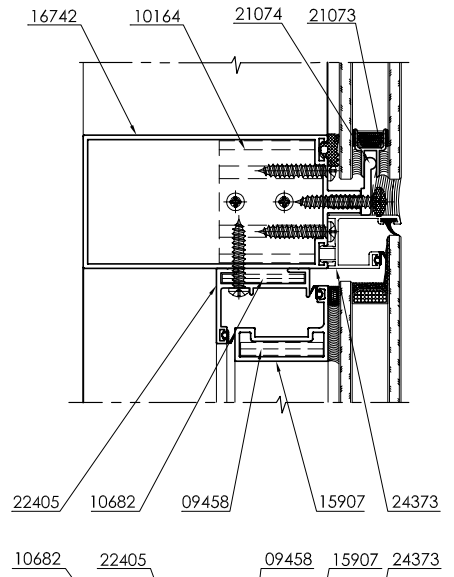

DETAIL : A-A

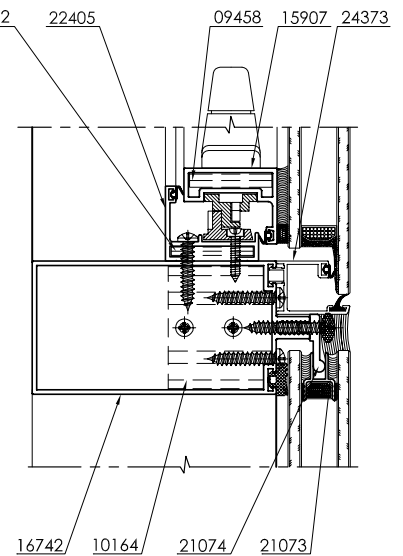
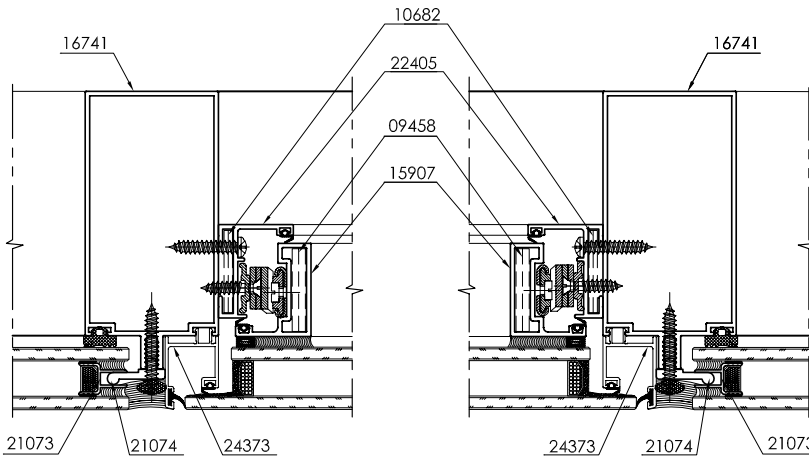

DETAIL : B-B

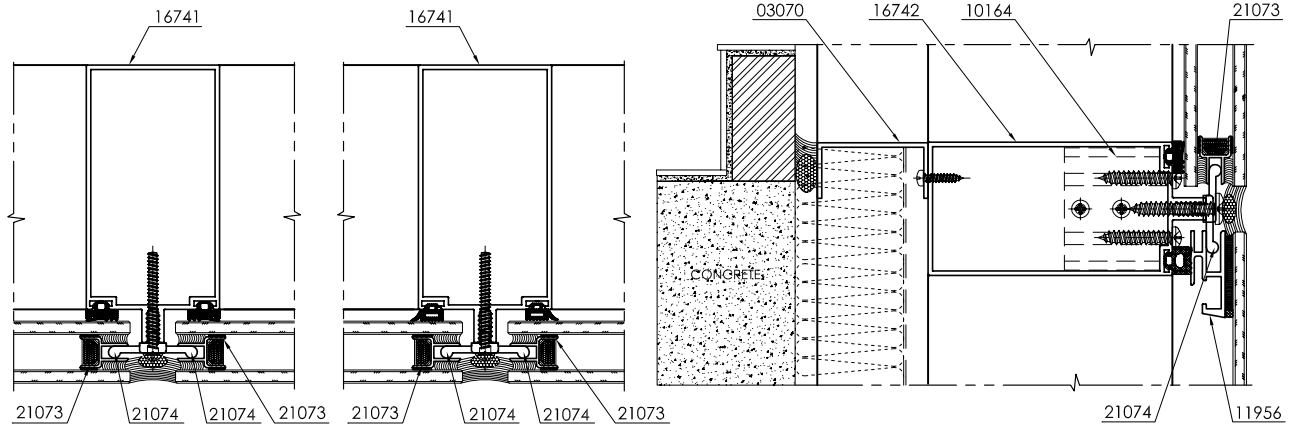

All dimensions in mm
 - - - - - Visible area

60mm Conventional

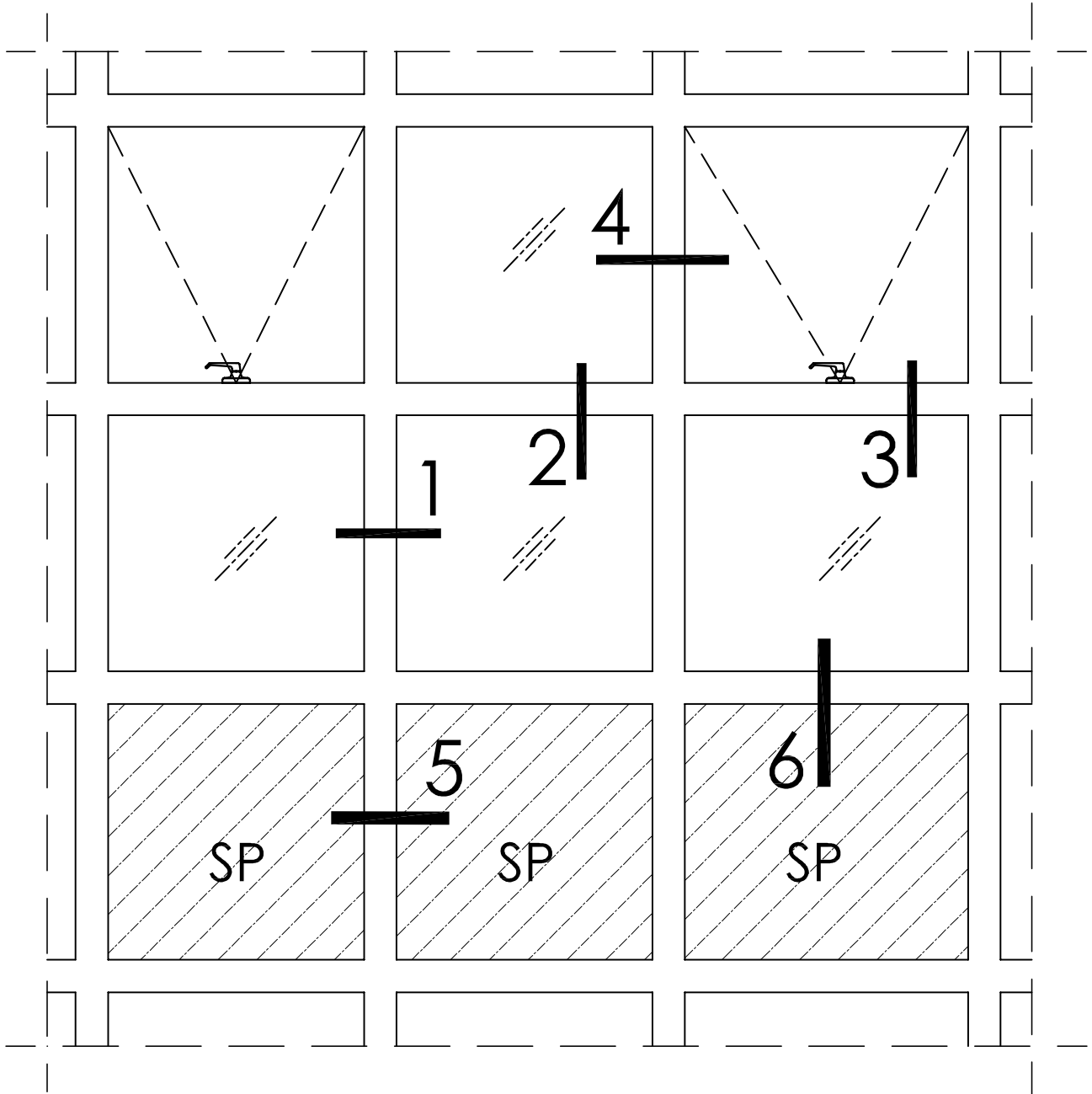

All dimensions in cross sections are shown in mm
Profile are not necessarily shown to scale

60mm Conventional
Detail - 1

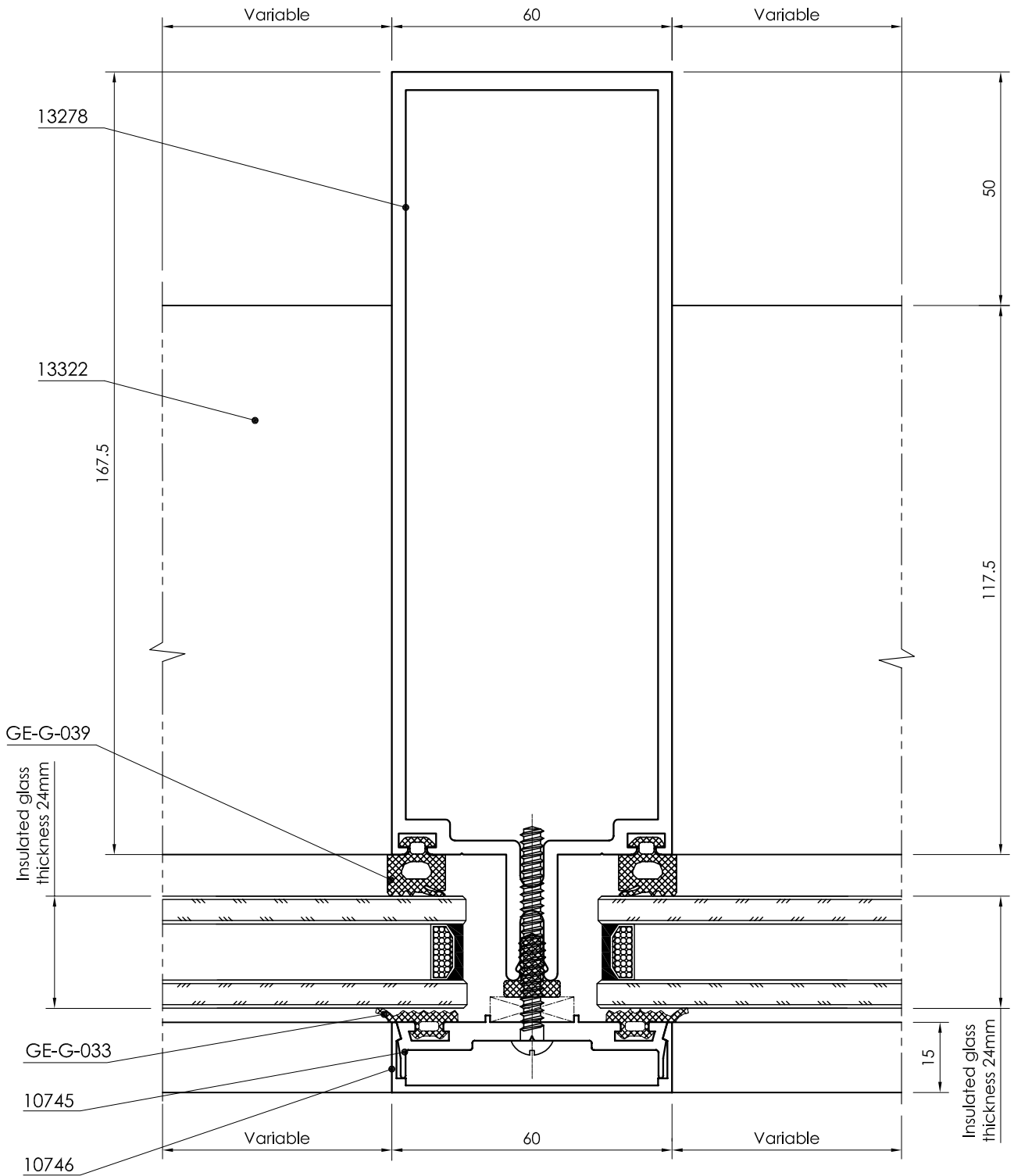

All dimensions in mm
----- Visible area

60mm Conventional
Detail - 2

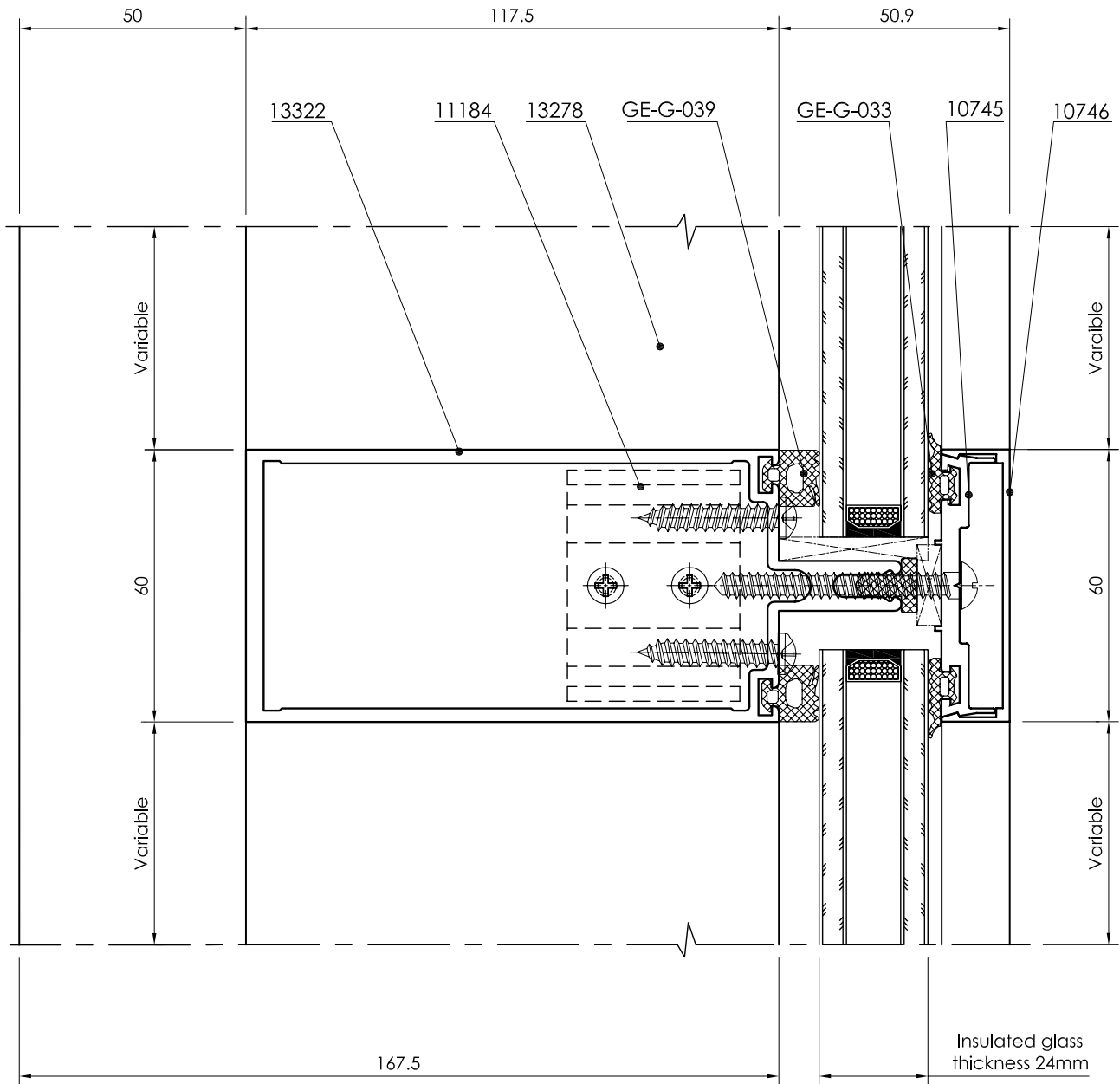

All dimensions in mm
Visible area_____

60mm Conventional
Detail - 3

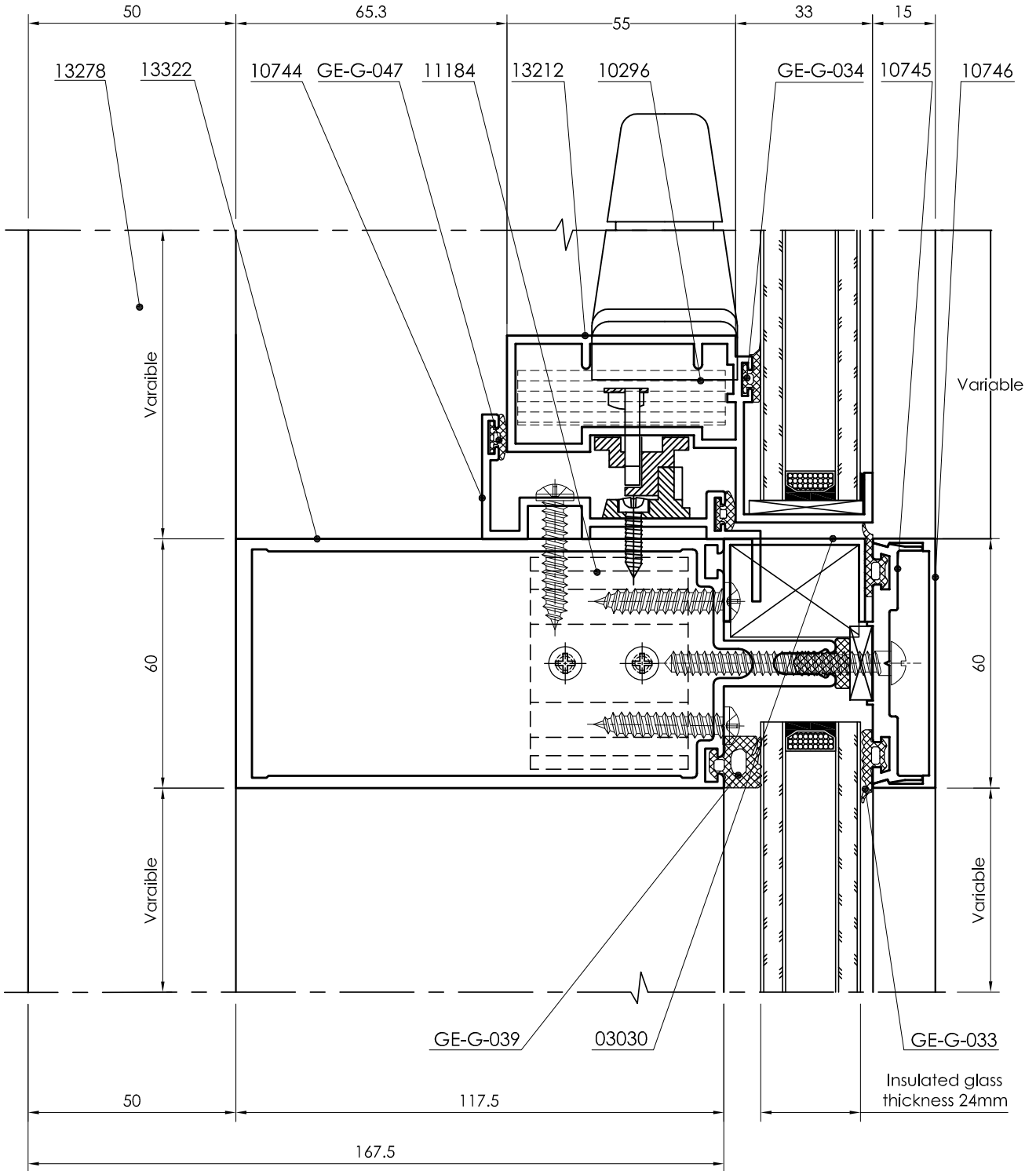

All dimensions in mm
----- Visible area

60mm Conventional
Detail - 4

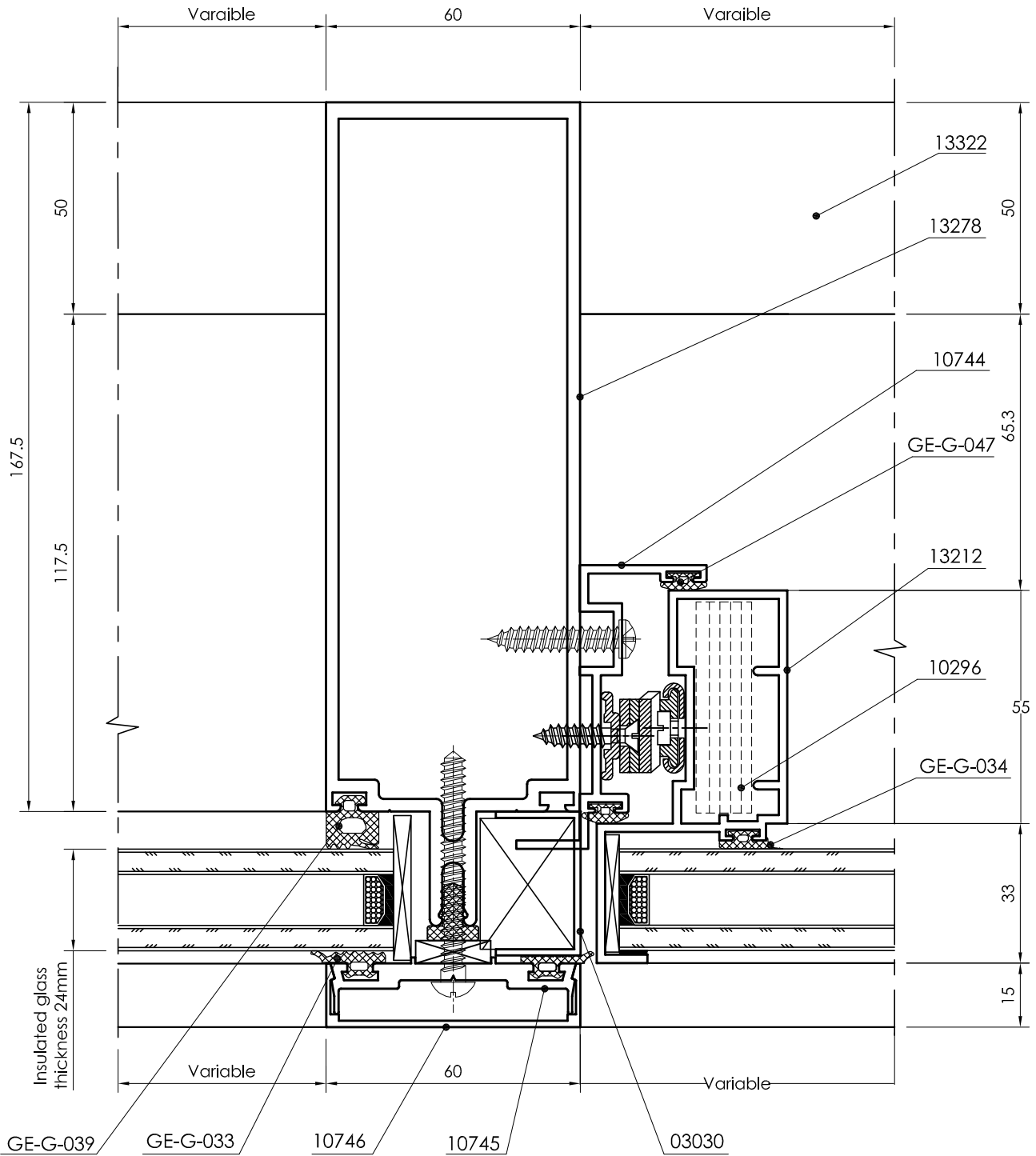

All dimensions in mm
Visible area_____

60mm Conventional
Detail - 5

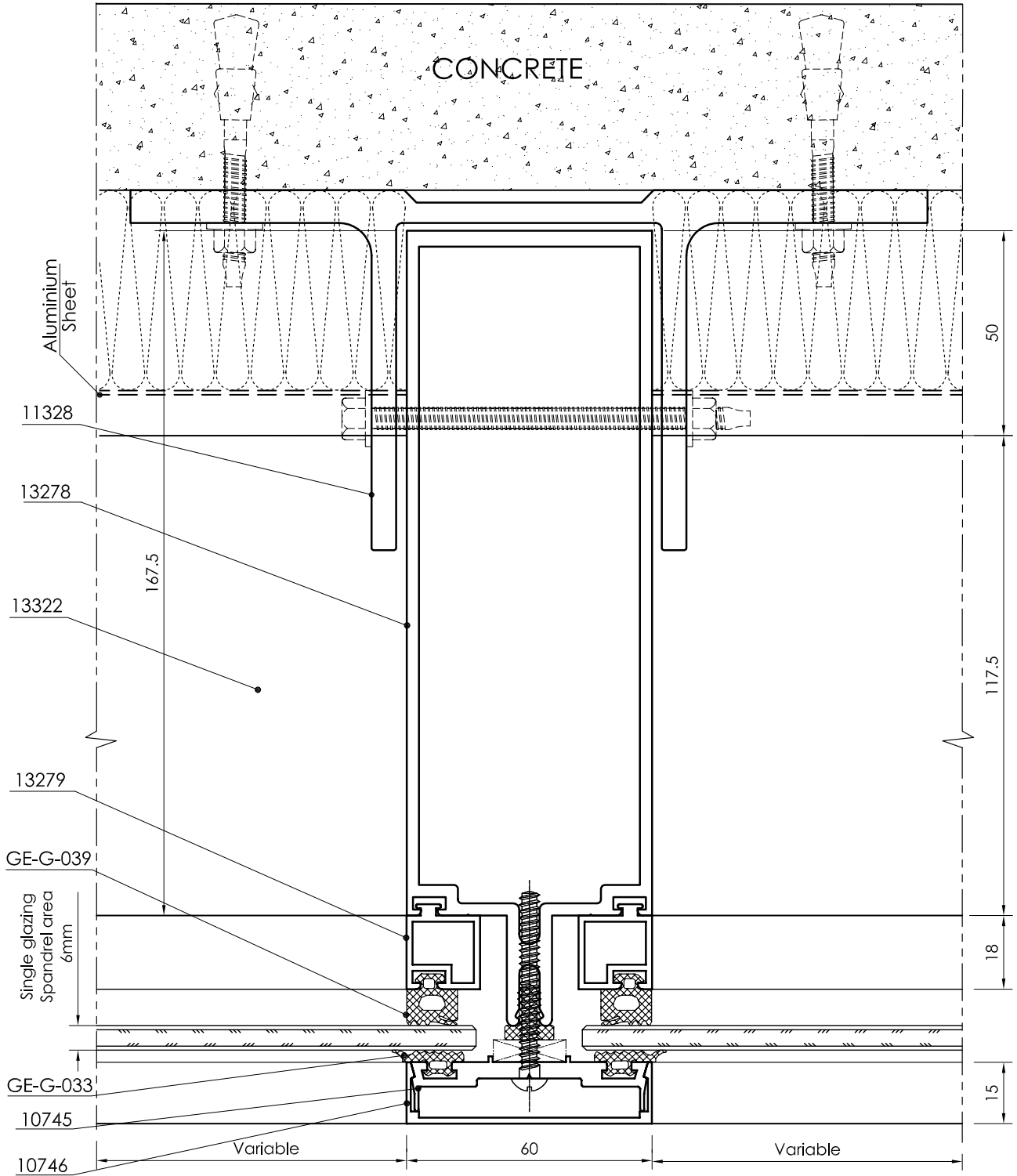

All dimensions in mm
----- Visible area

60mm Conventional
Detail - 6

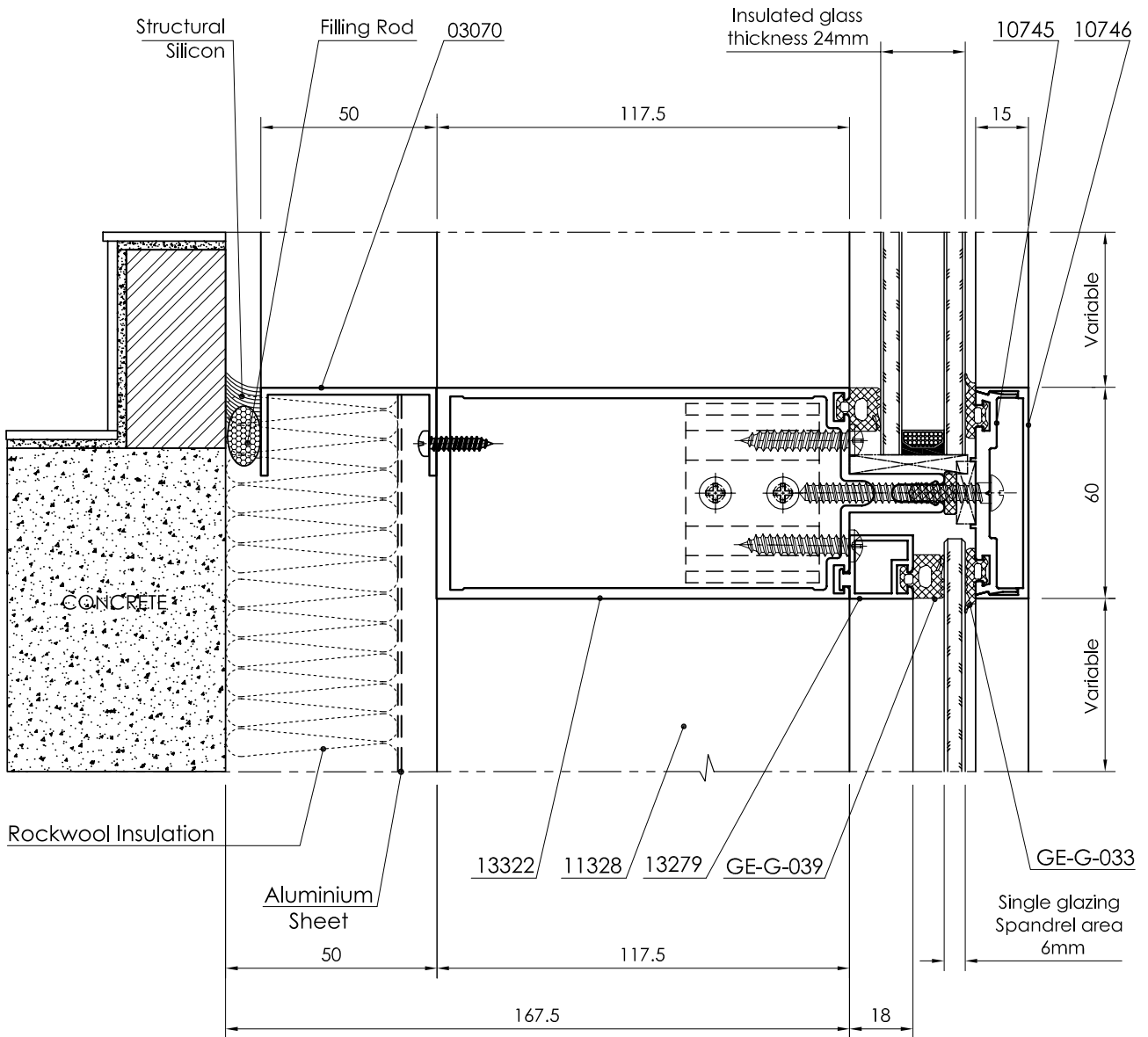

All dimensions in mm
Visible area_____

60mm Conventional

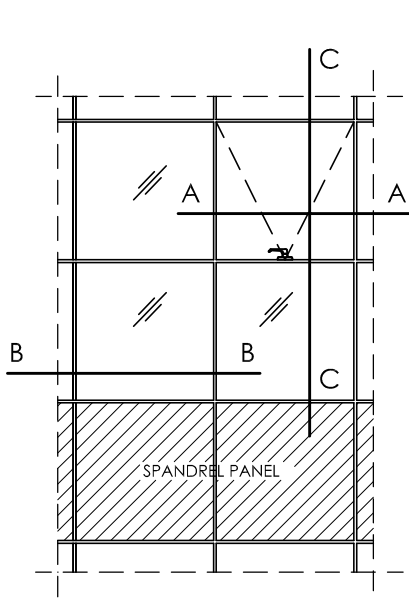

Profiles		
Description	Shape	Section No.
Mullion		13278
Transom		13322
Frame		10744
Sash		13212
Brusher Plate		10745
Cover Plate		10746
Single glass adaptor		13279
Connector		11184
Corner cleat		10296
U-Channel		03070
U-Channel		03030
Bracket		11328

DETAIL : C-C

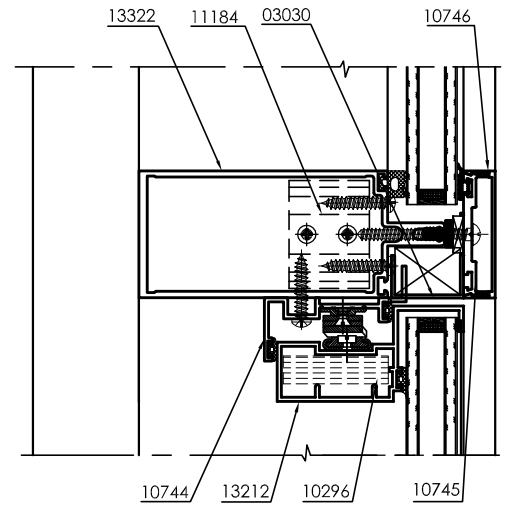

DETAIL : A-A

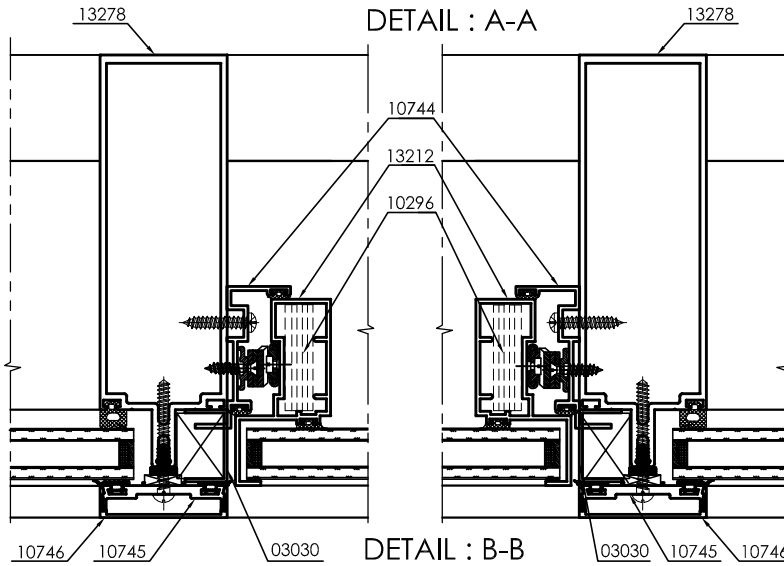

DETAIL : B-B

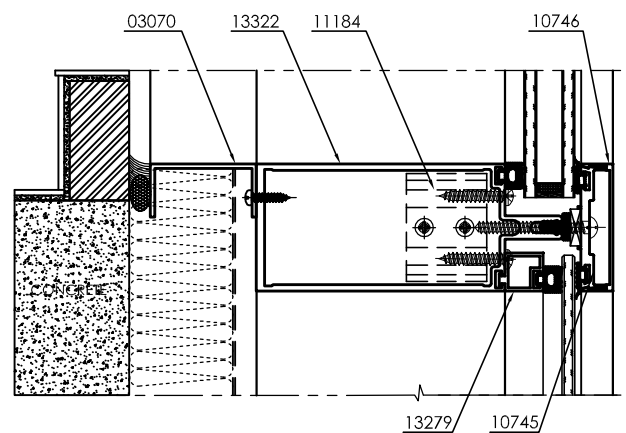
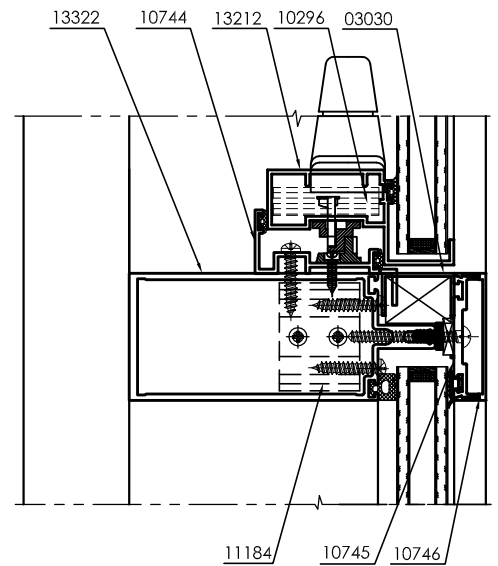
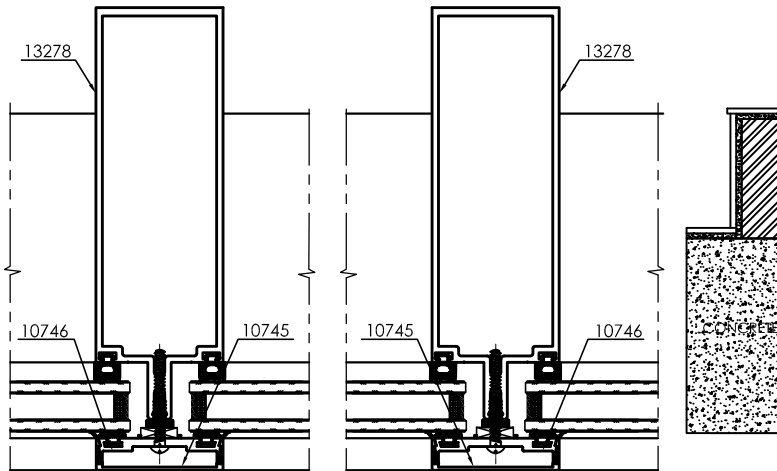

All dimensions in mm
 ----- Visible area

60mm 2-way Structural Glazing

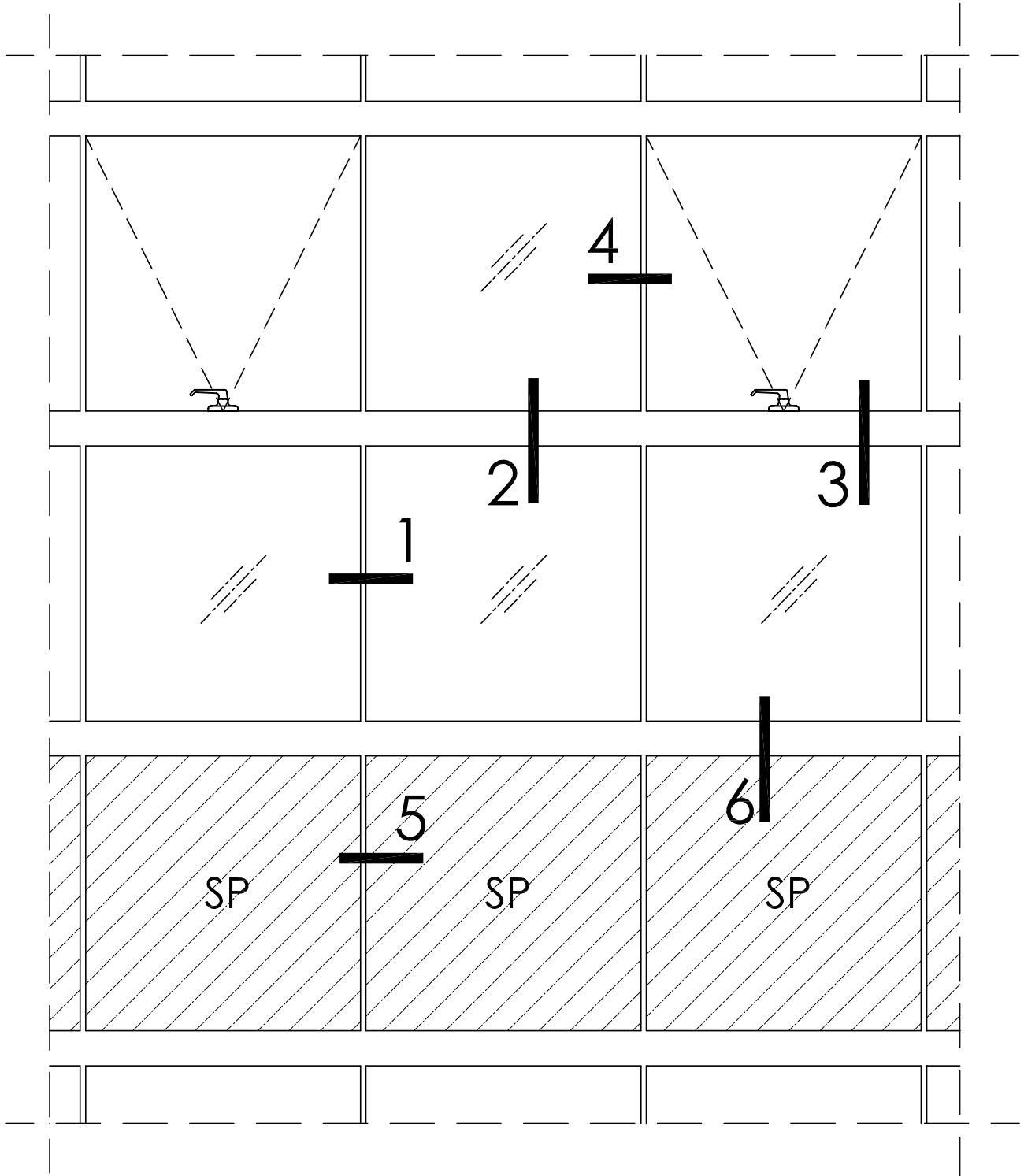

All dimensions in cross sections are shown in mm
 Profile are not necessarily shown to scale

60mm 2-way Structural Glazing
Detail - 1

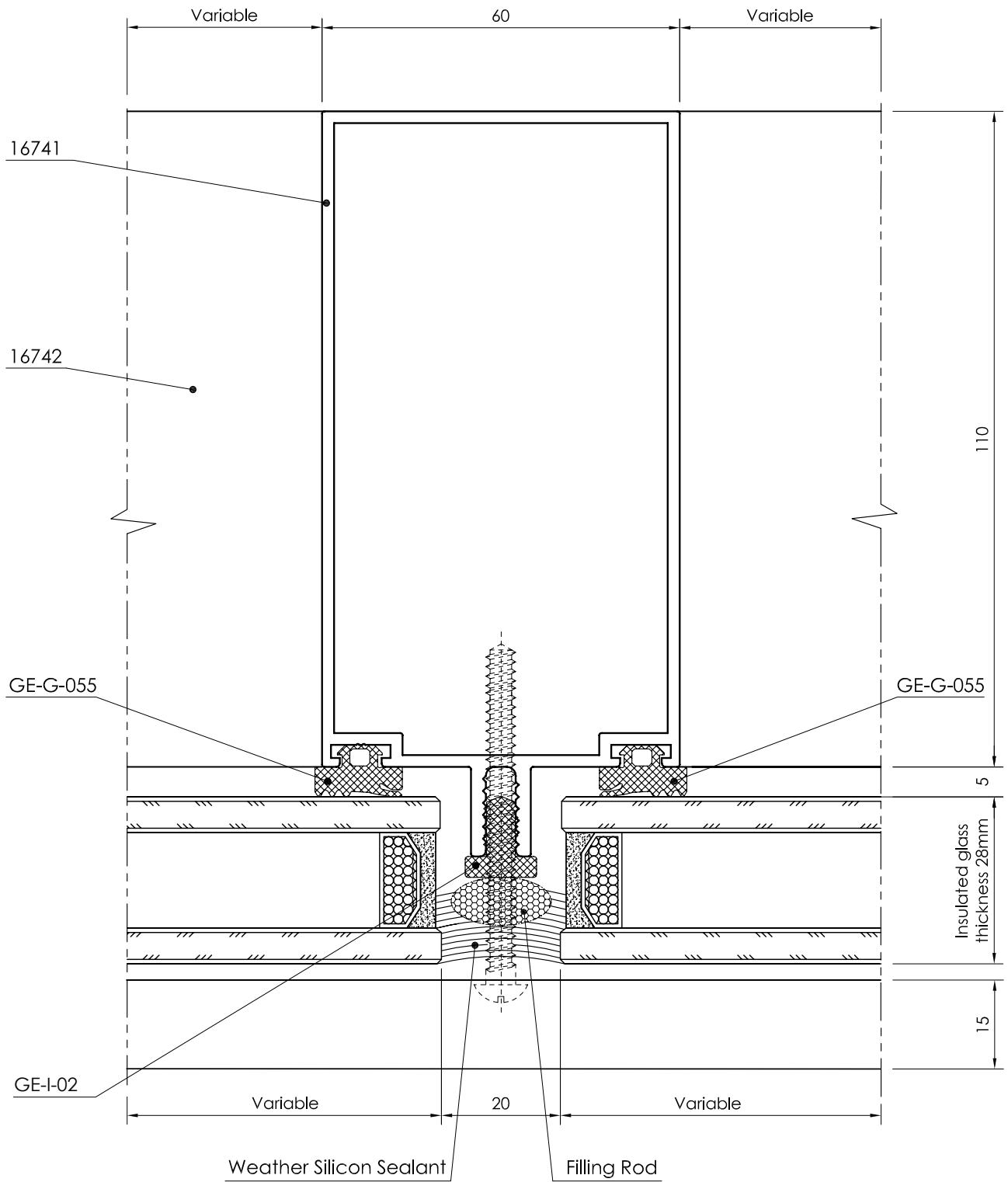

All dimensions in mm
----- Visible area

60mm 2-way Structural Glazing
Detail - 2

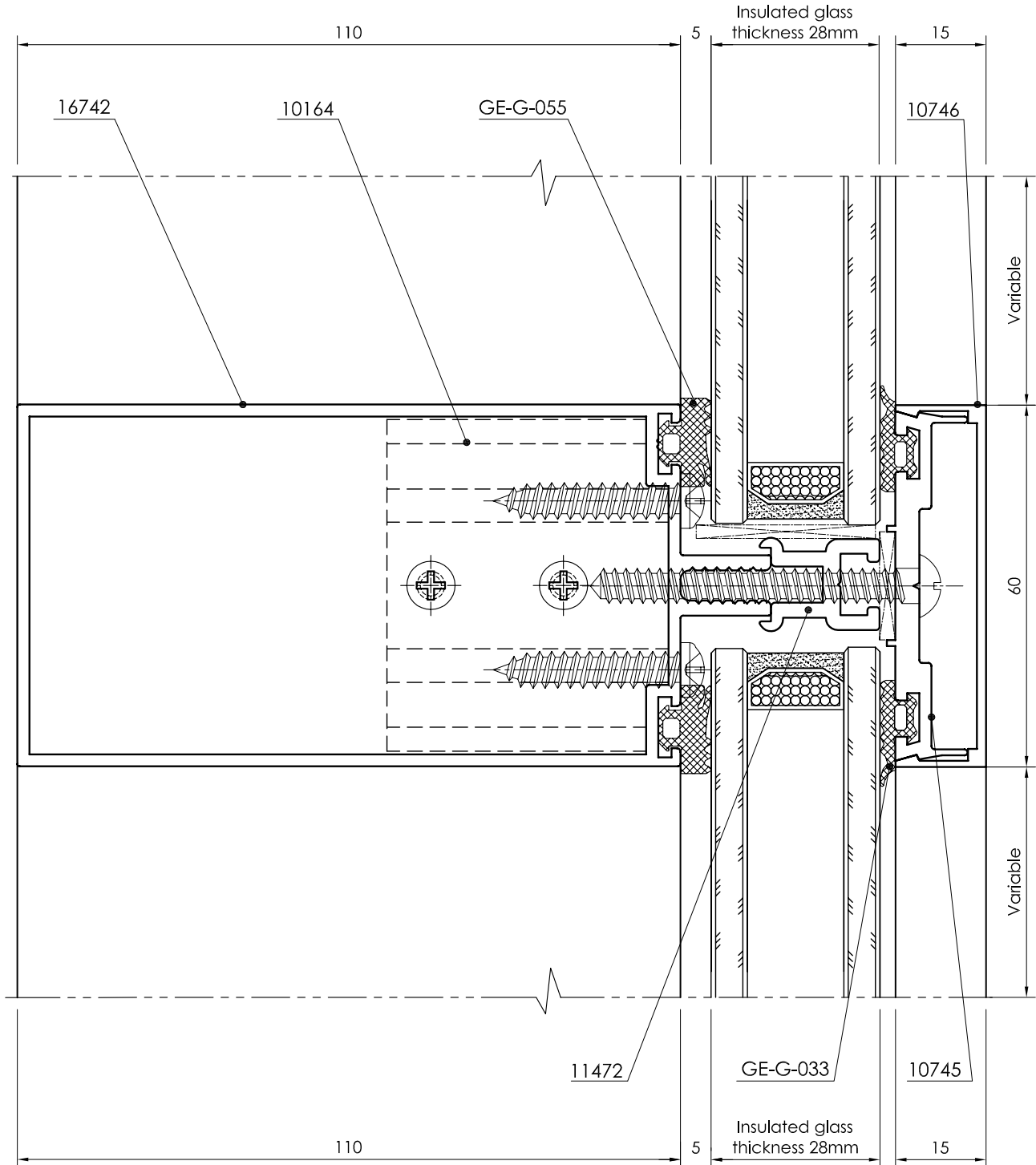

All dimensions in mm
Visible area_____

60mm 2-way Structural Glazing
Detail - 3

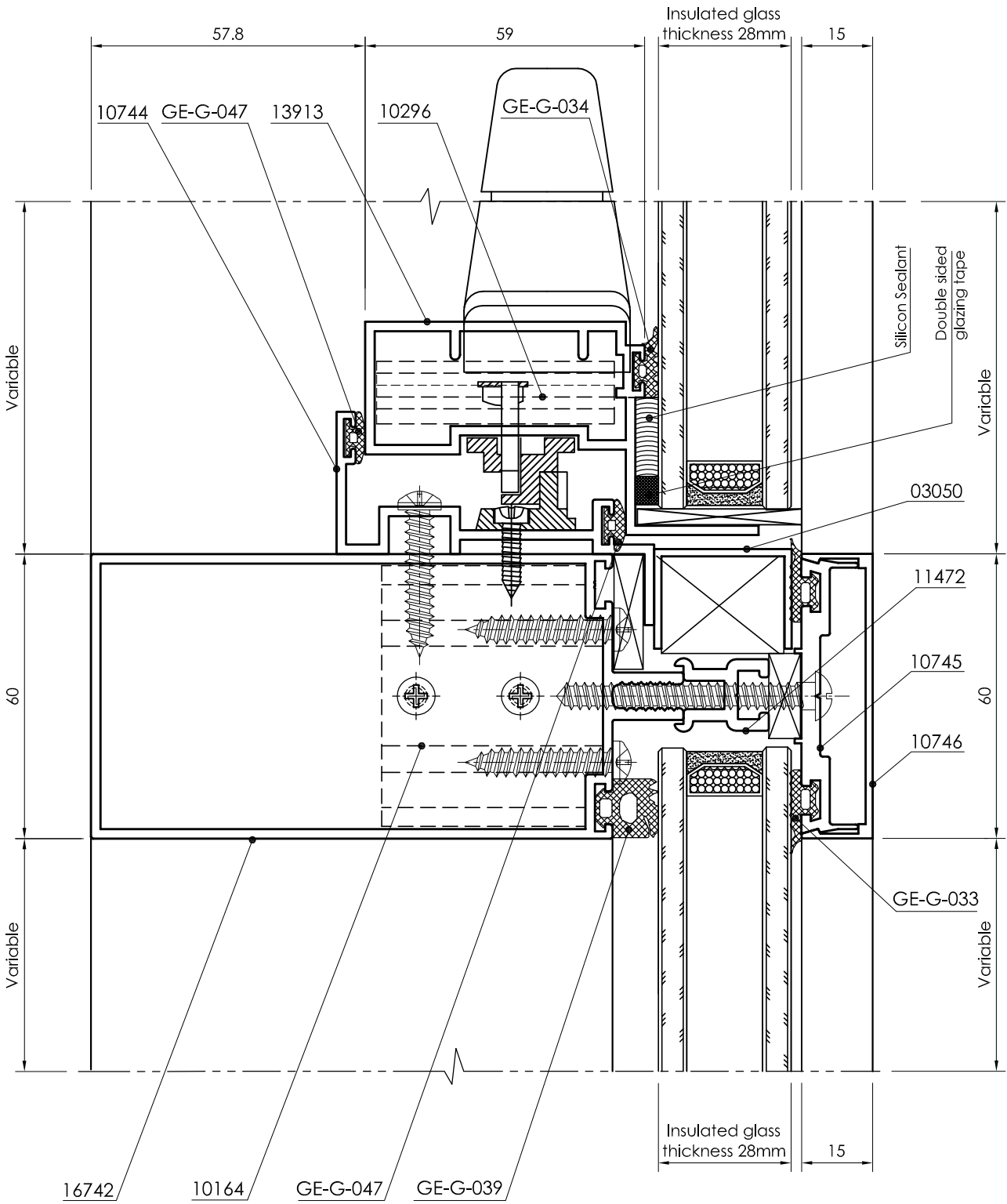

All dimensions in mm
----- Visible area

60mm 2-way Structural Glazing
Detail - 4

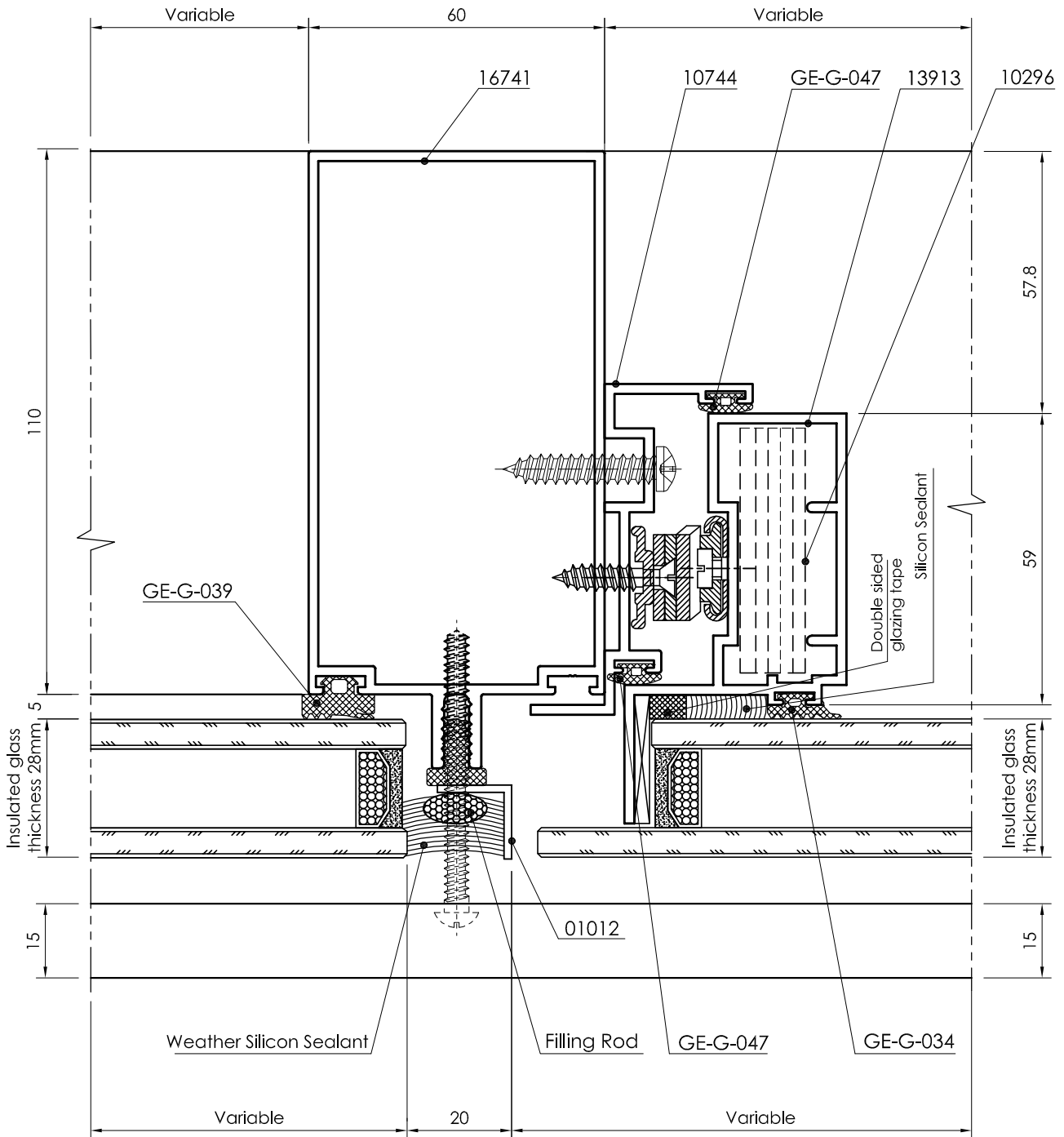

All dimensions in mm
Visible area_____

60mm 2-way Structural Glazing
Detail - 5

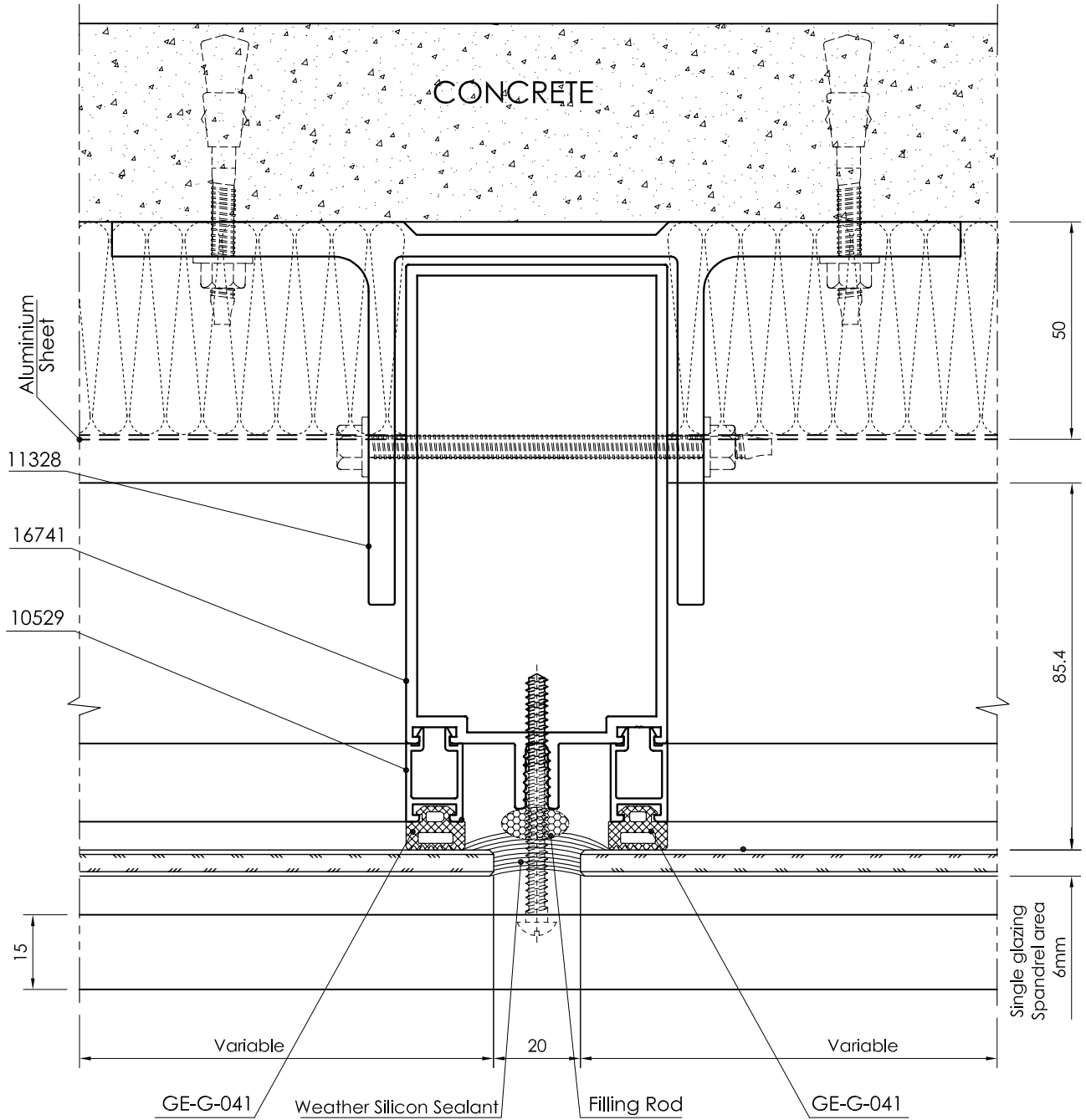

All dimensions in mm
----- Visible area

60mm 2-way Structural Glazing
Detail - 6

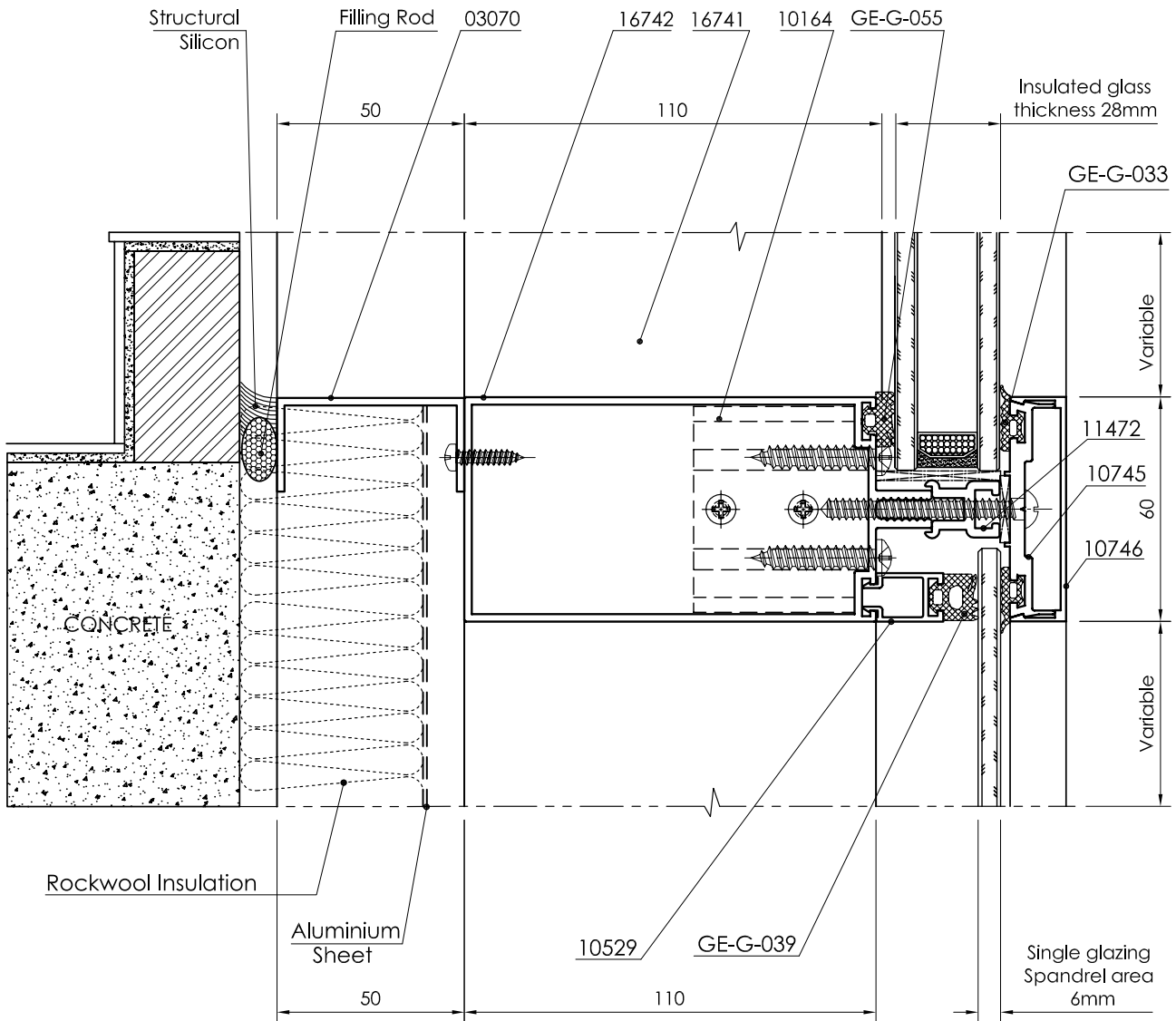

All dimensions in mm
Visible area_____

60mm 2-way Structural Glazing

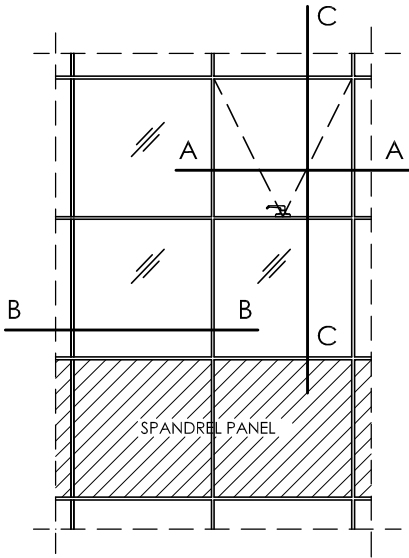

Profiles		
Description	Shape	Section No
Mullion/Transom		16741 / 16742
Frame		10744
Sash		13913
Brusher Plate		10745
Cover Plate		10746
Connector		10164
Corner cleat		10296
Clip Profile		10529
Adaptor		11472
U-Channel		03070
15X15X1.5 Angle		01012
Bracket		11328

DETAIL : C-C

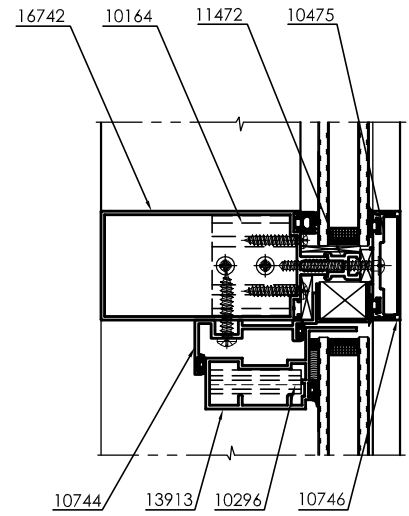

DETAIL : A-A

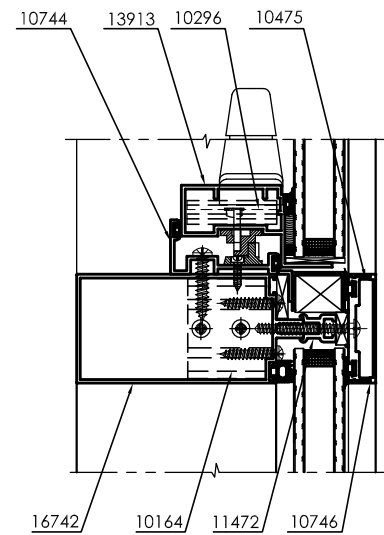
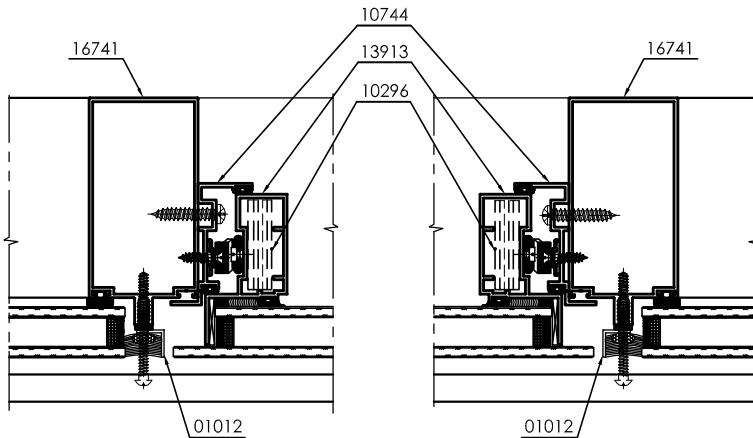

DETAIL : B-B

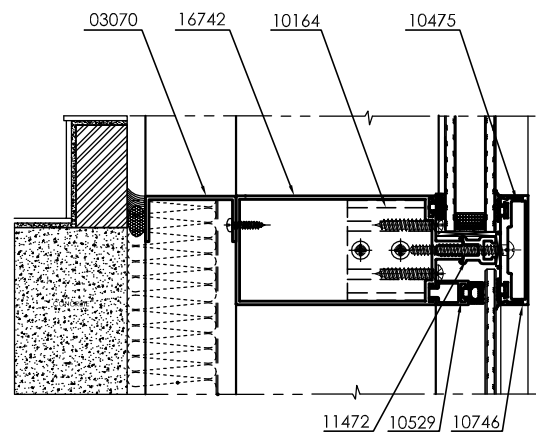
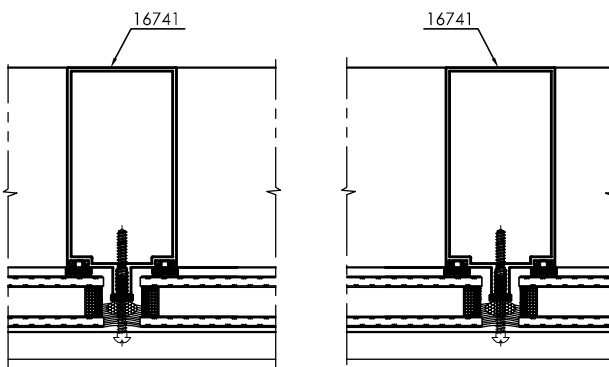

All dimensions in mm
 ----- Visible area

60mm 4-way Structural Glazing Thermal Break

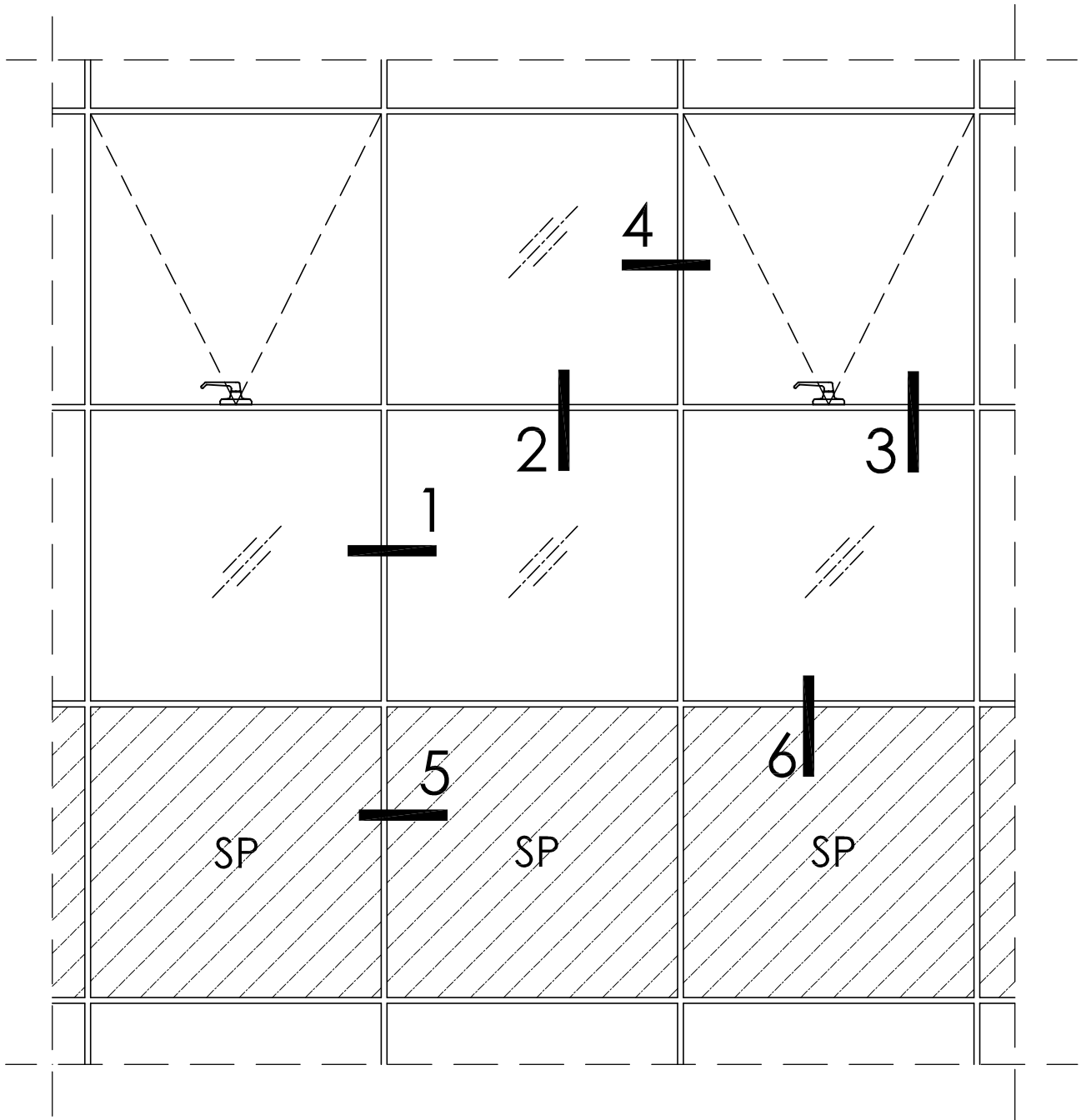

All dimensions in mm
Visible area_____

60mm 4-way Structural Glazing
Detail - 1

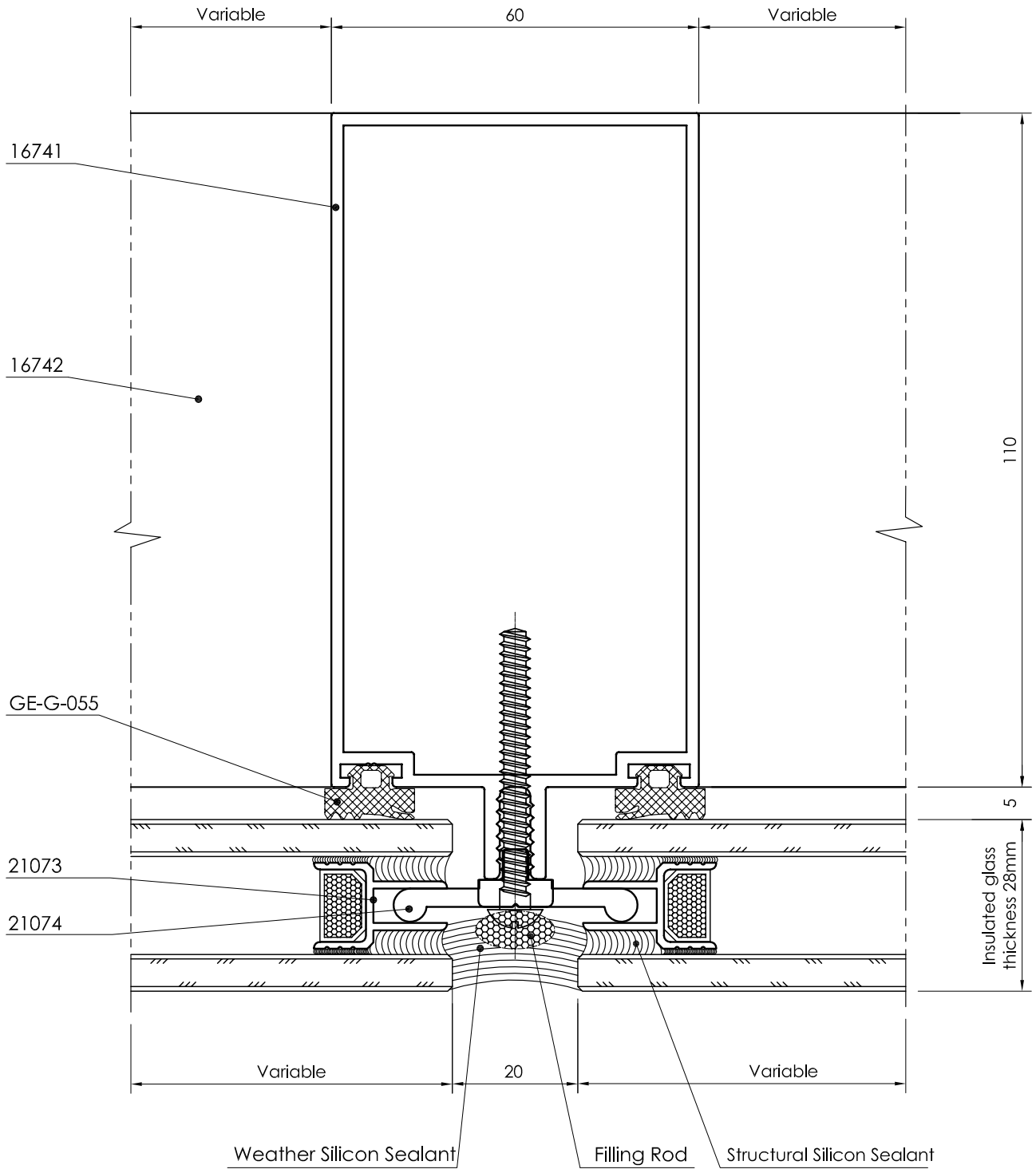

All dimensions in mm
----- Visible area

60mm 4-way Structural Glazing
Detail - 2

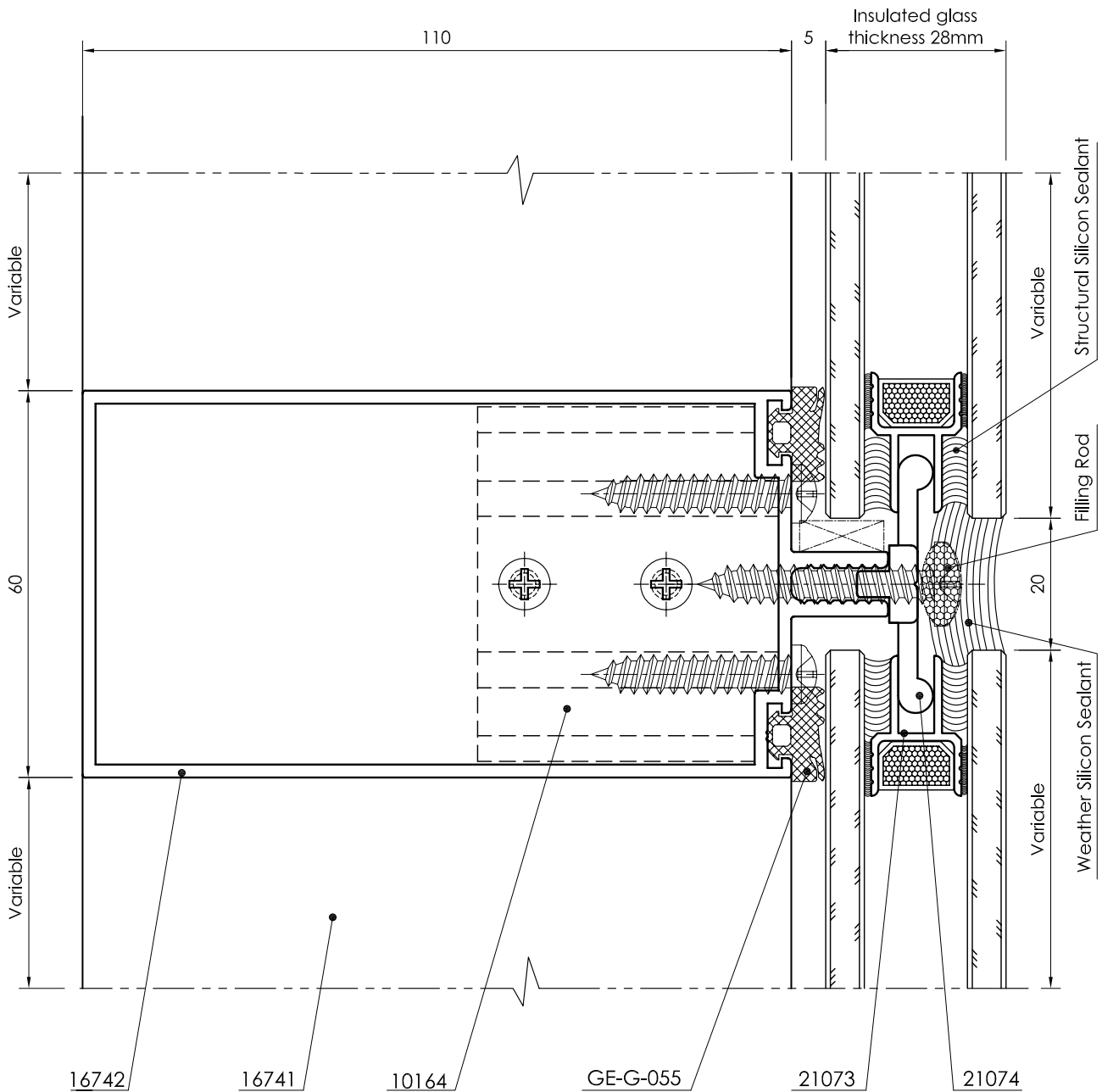

All dimensions in mm
Visible area_____

60mm 4-way Structural Glazing
Detail - 3

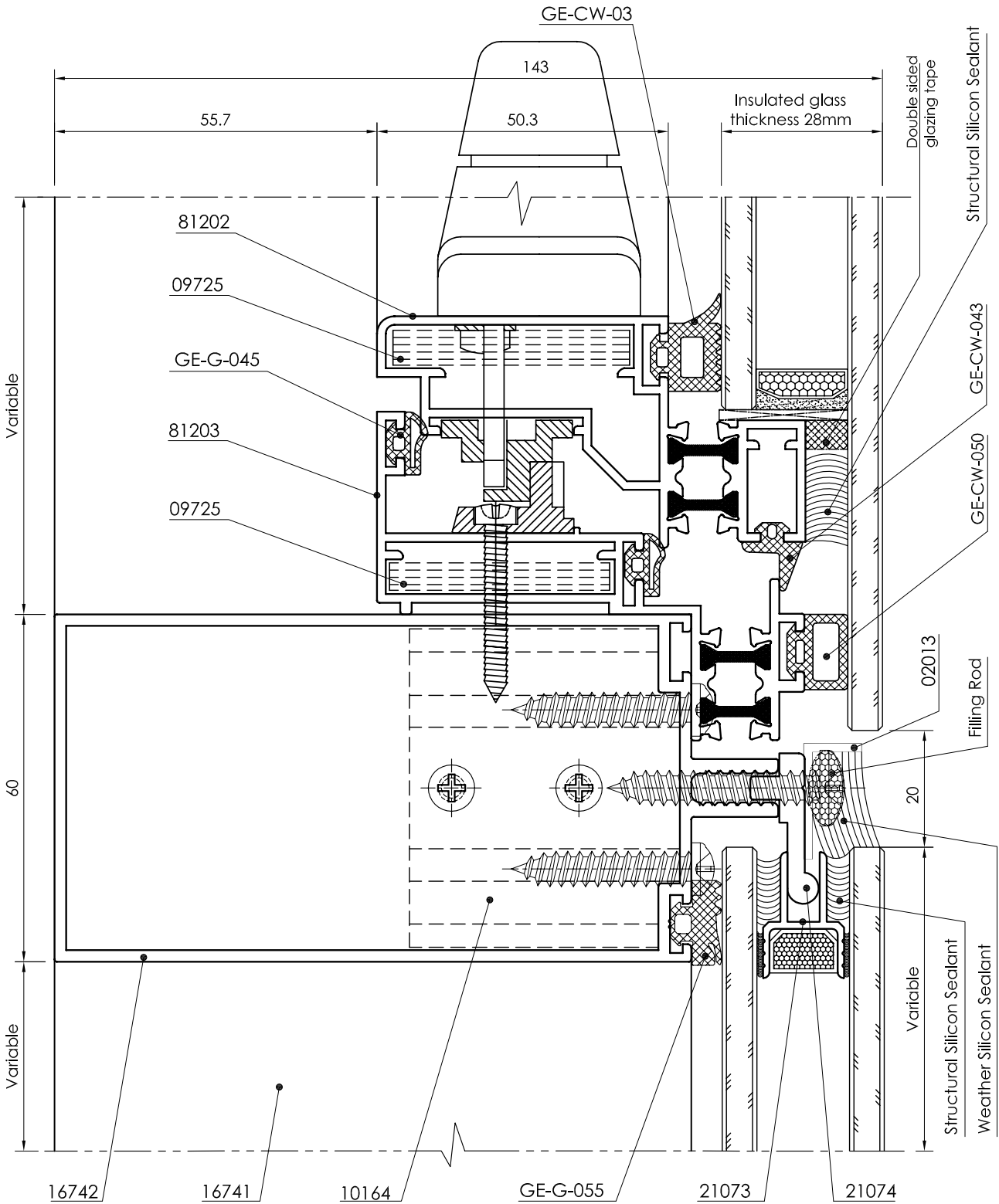

All dimensions in mm
----- Visible area

60mm 4-way Structural Glazing

Detail - 4

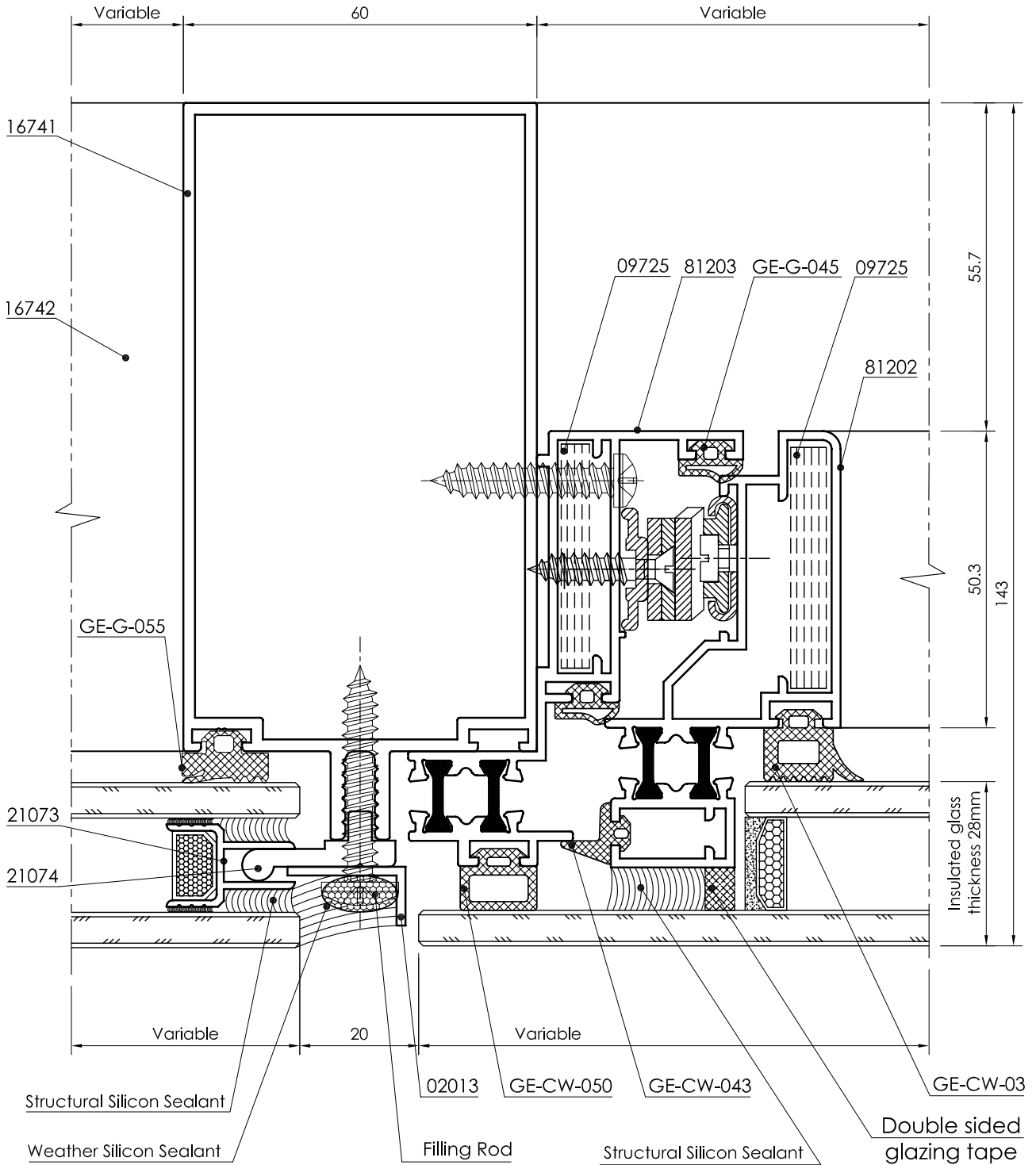

All dimensions in mm
Visible area_____

60mm 4-way Structural Glazing
Detail - 5

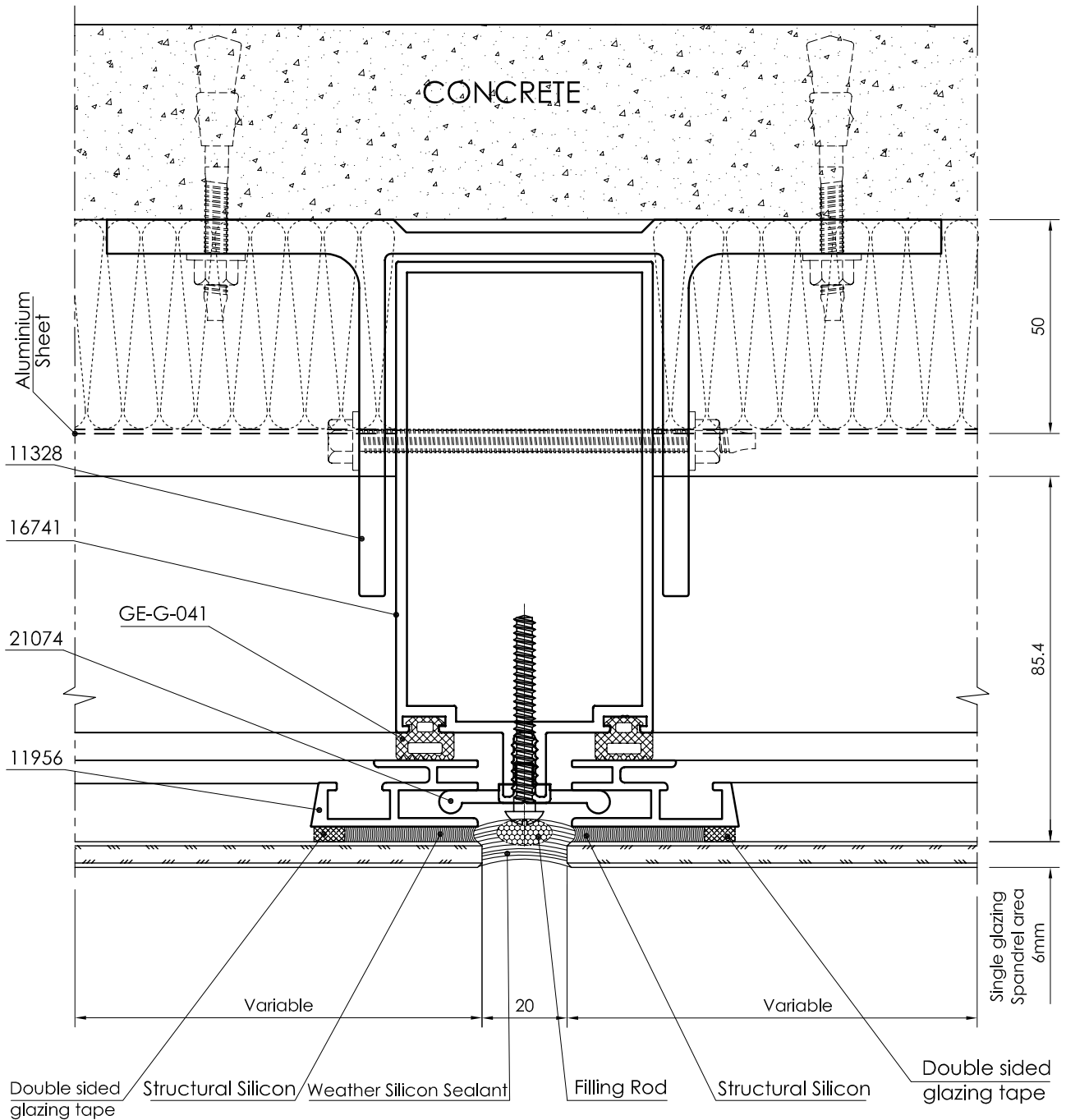

All dimensions in mm
----- Visible area

60mm 4-way Structural Glazing
Detail - 6

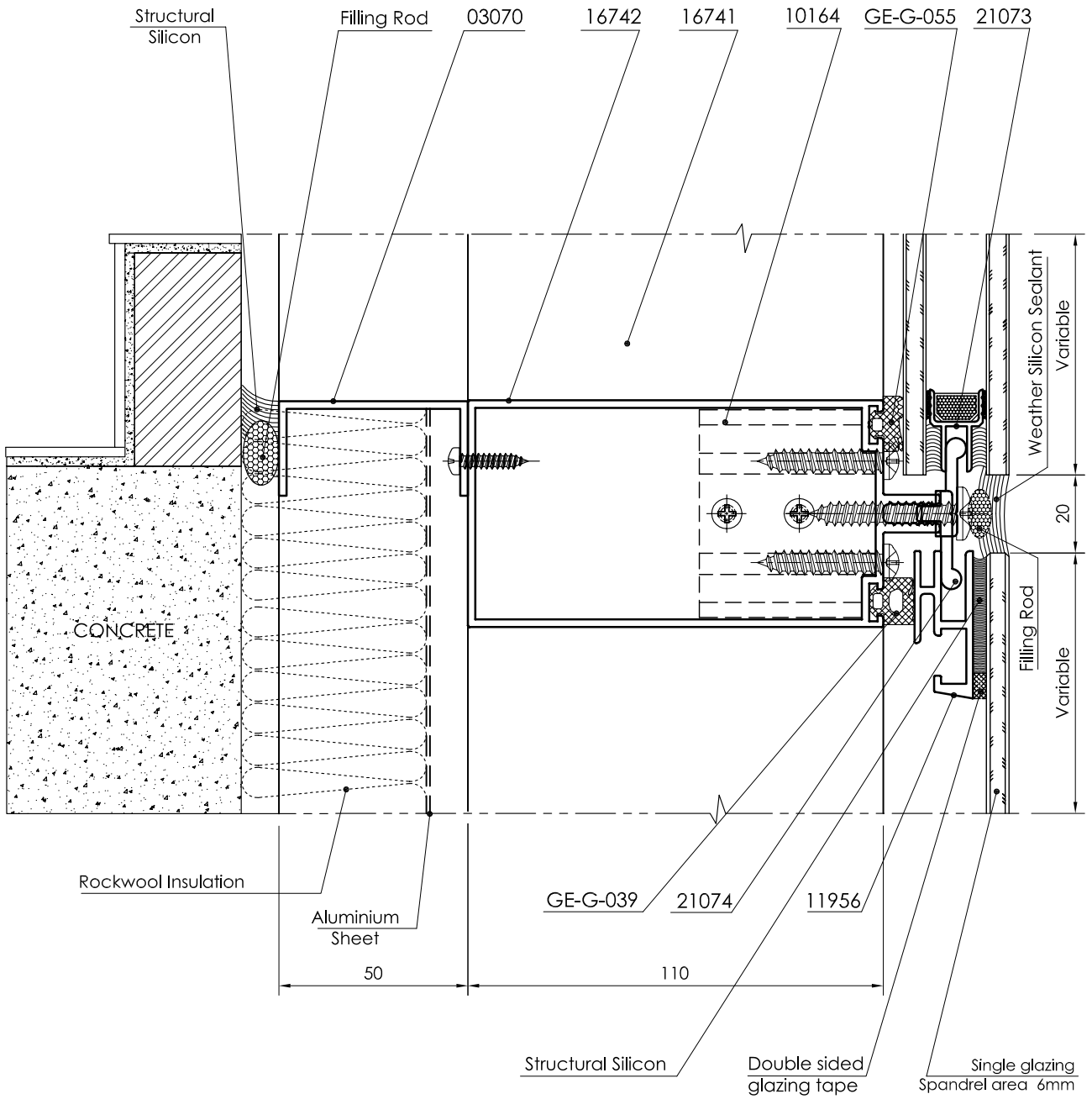

All dimensions in mm
Visible area_____

60mm 4-way Structural Glazing
Thermal Break

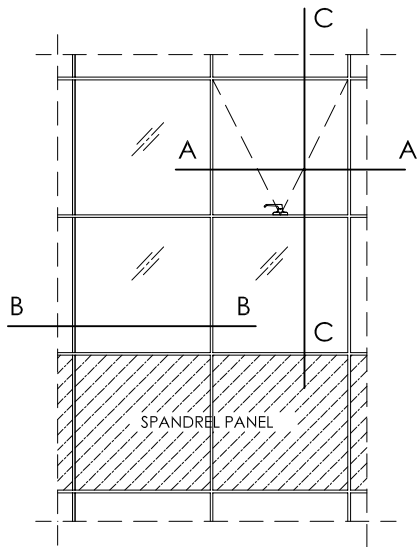

Profiles		
Description	Shape	Section No.
Curtain wall		16741 / 16742
Frame		81203
Sash		81202
Connector		10164
Corner cleat		09725
Glass spacer		21073
Glass Toggler		21074
Glass spacer		11956
20X10X1.5 Angle		02013
Bracket		11328
U-Channel		03070

DETAIL : C-C

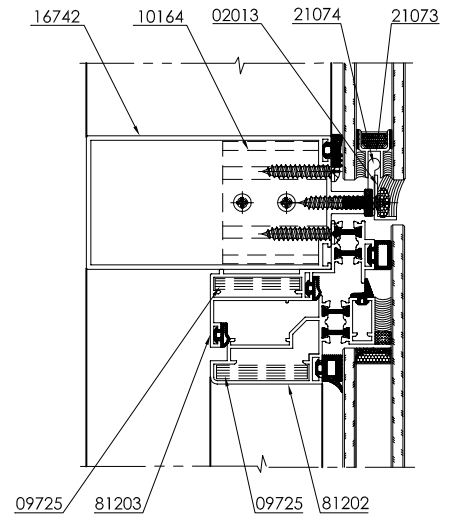

DETAIL : A-A

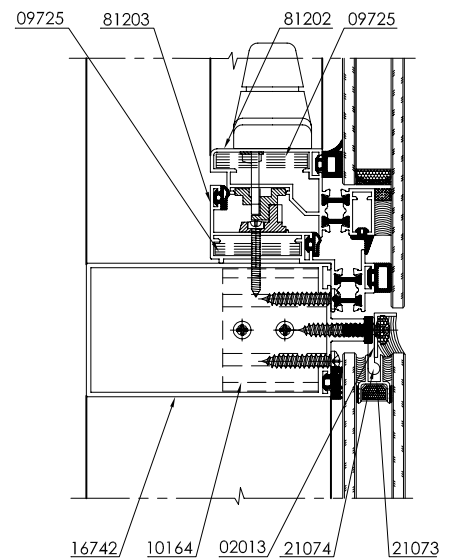
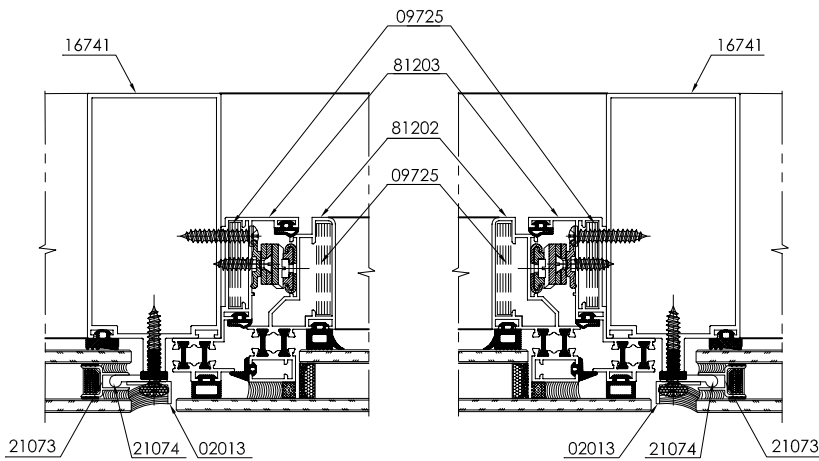

DETAIL : B-B

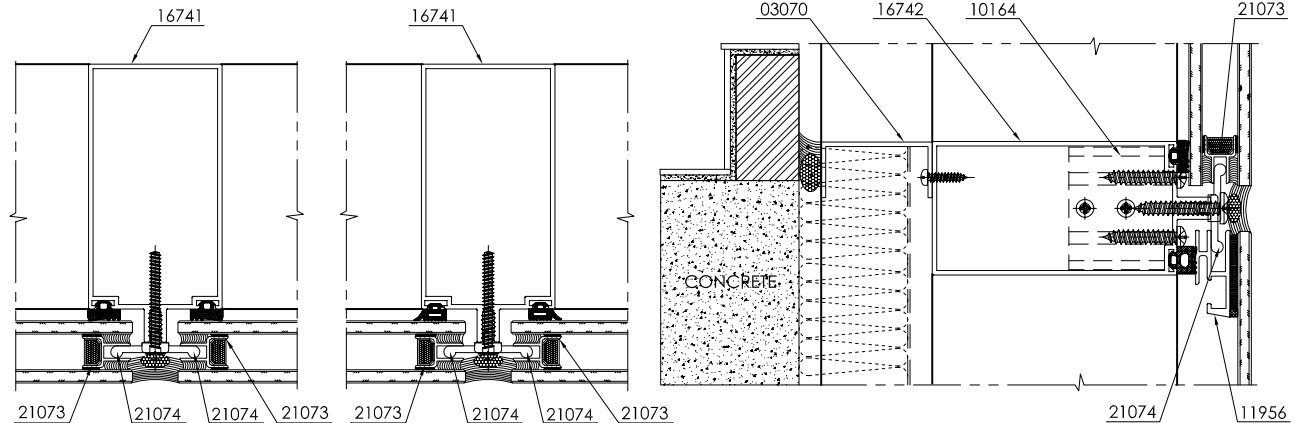

All dimensions in mm
----- Visible area

3D SECTIONS

60mm Curtain Wall

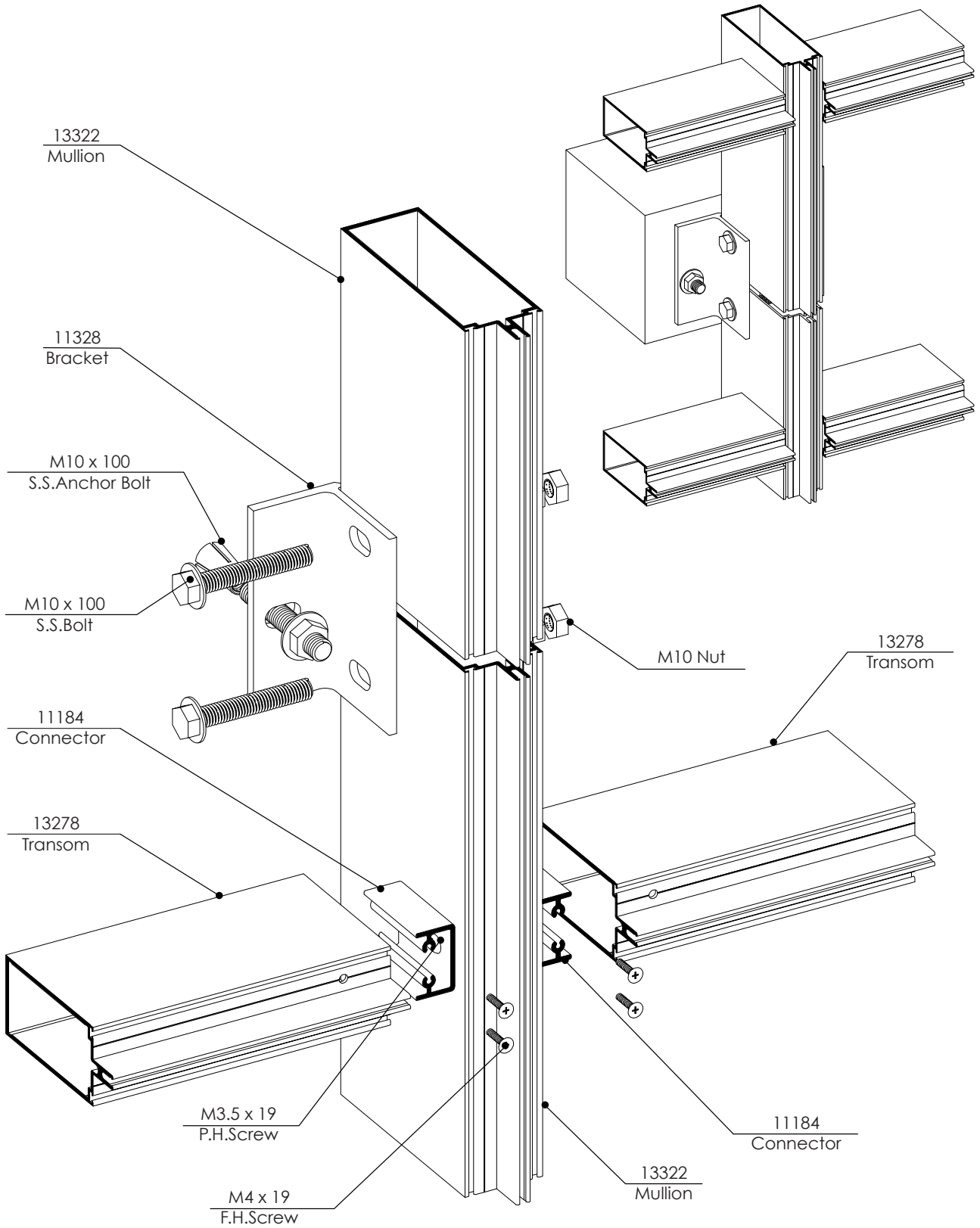

60mm Structural Glazing

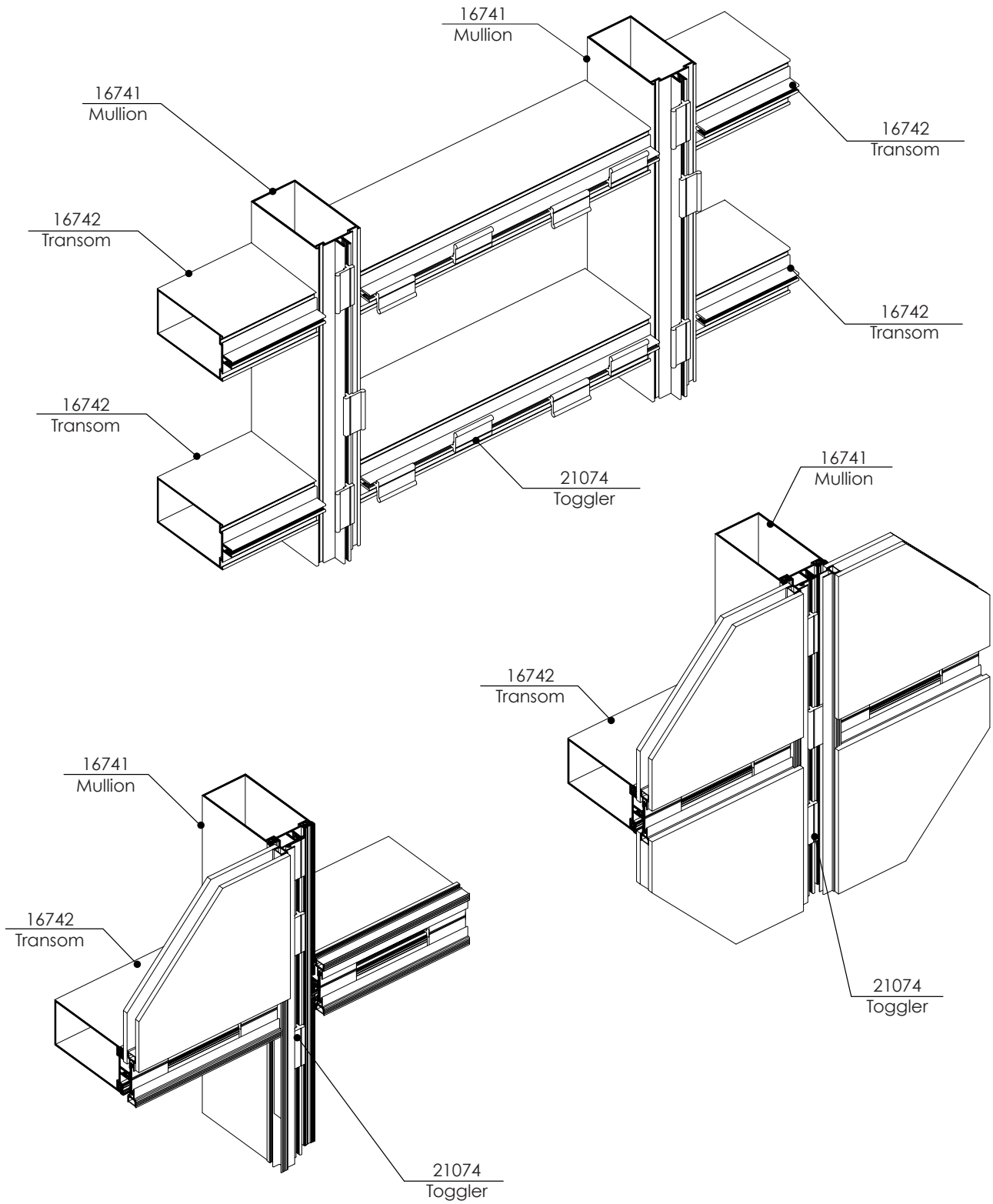

60mm Curtain Wall

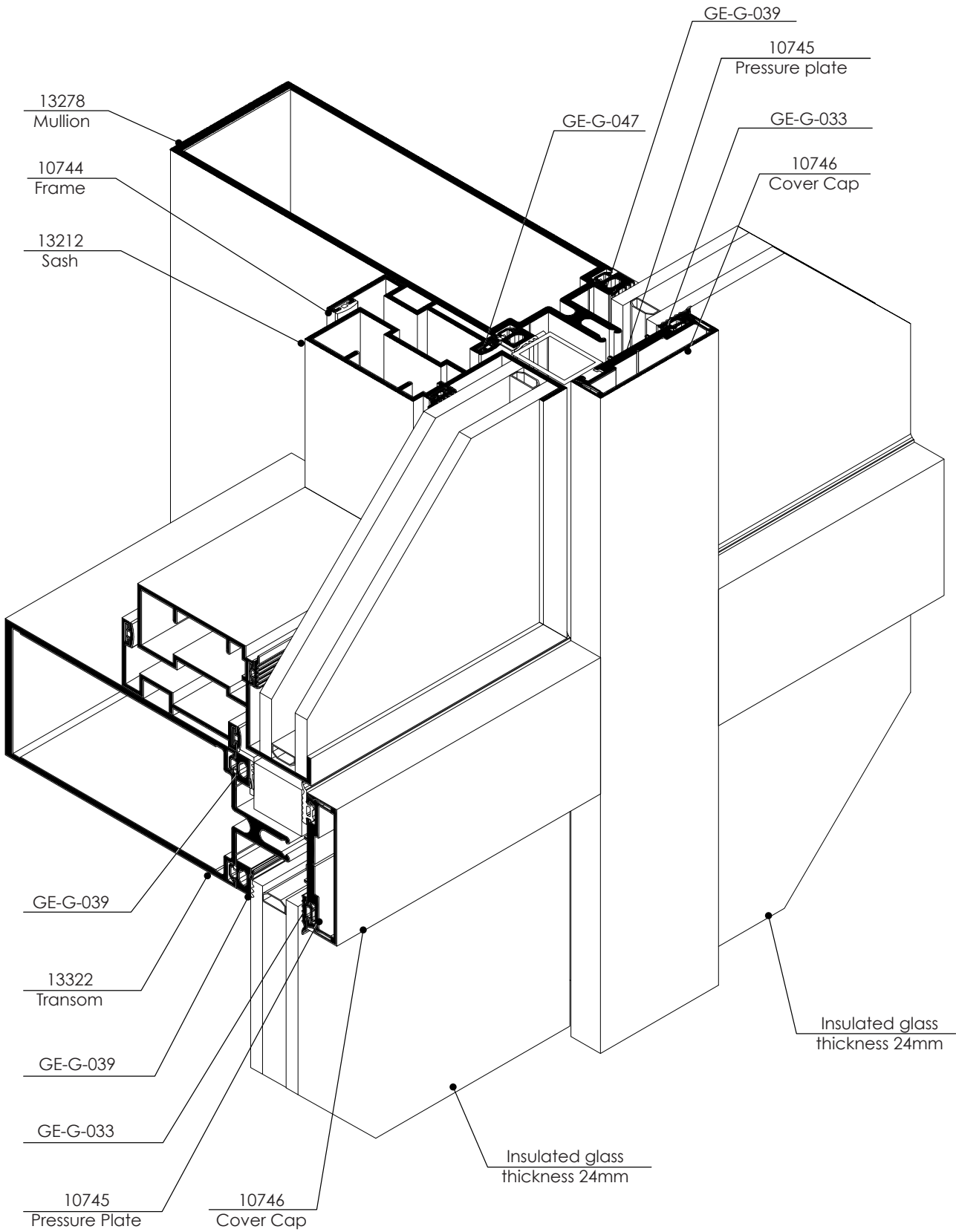

60mm Curtain Wall

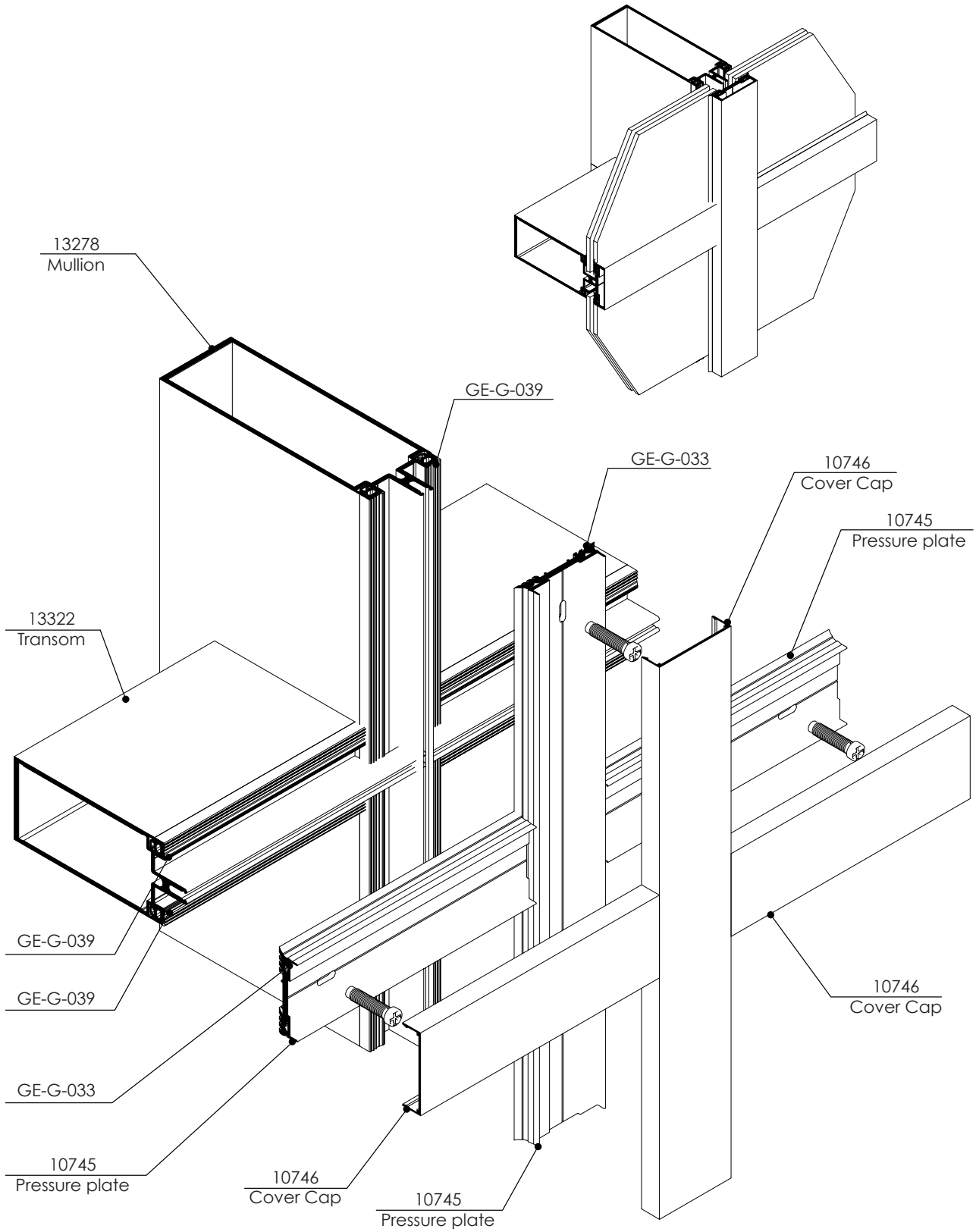

All rights reserved.

No part of this publication may be reproduced, stored in a retrieval system or transmitted in any form or by any means electronic, mechanical, photocopying, recording or otherwise, without prior permission of Gulf Extrusions.

